

TC74VHC273F, TC74VHC273FW, TC74VHC273FT

OCTAL D - TYPE FLIP - FLOP WITH CLEAR

The TC74VHC273 is an advanced high speed CMOS OCTAL D - TYPE FLIP FLOP fabricated with silicon gate C²MOS technology.

It achieves the high speed operation similar to equivalent Bipolar Schottky TTL while maintaining the CMOS low power dissipation.

Information signals applied to D inputs are transferred to the Q outputs on the positive going edge of the clock pulse.

When the CLR input is held "L", the Q outputs are at a low logic level independent of the other inputs.

An input protection circuit ensures that 0 to 5.5V can be applied to the input pins without regard to the supply voltage. This device can be used to interface 5V to 3V systems and two supply systems such as battery back up. This circuit prevents device destruction due to mismatched supply and input voltages.

FEATURES :

- High Speed..... $f_{MAX} = 165\text{MHz}(\text{typ.})$
at $V_{CC} = 5\text{V}$
- Low Power Dissipation..... $I_{CC} = 4\mu\text{A}(\text{Max.})$ at $T_a = 25^\circ\text{C}$
- High Noise Immunity..... $V_{NIH} = V_{NIL} = 28\% V_{CC} (\text{Min.})$
- Power Down Protection is provided on all inputs.
- Balanced Propagation Delays..... $t_{PLH} \approx t_{PHL}$
- Wide Operating Voltage Range..... $V_{CC} (\text{opr}) = 2\text{V} \sim 5.5\text{V}$
- Low Noise $V_{OLP} = 0.9\text{V} (\text{Max.})$
- Pin and Function Compatible with 74ALS273

TRUTH TABLE

INPUTS			OUTPUT	FUNCTION
CLR	D	CK	Q	
L	X	X	L	Clear
H	L		L	—
H	H		H	—
H	X		Q _n	No change

X : Don't Care

(Note) The JEDEC SOP (FW) is not available in Japan.

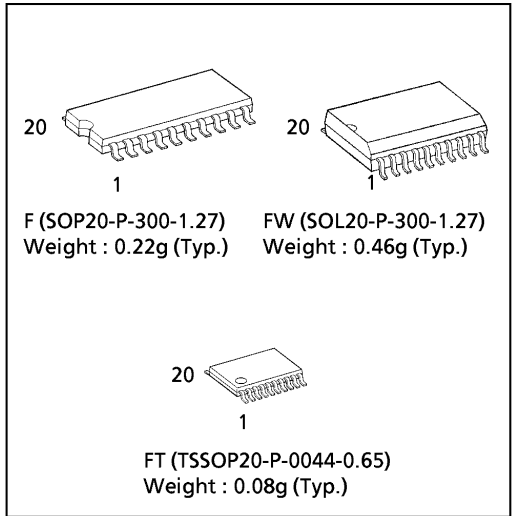

PIN ASSIGNMENT

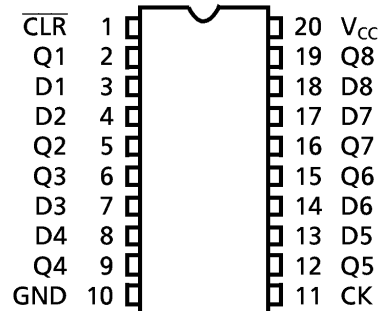

(TOP VIEW)

IEC LOGIC SYMBOL

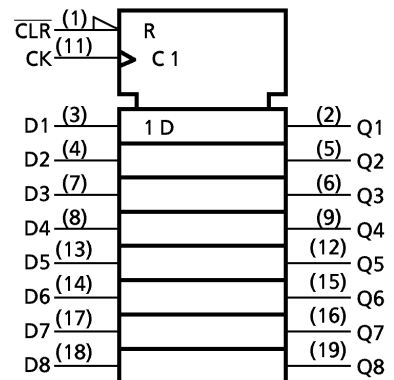

980910EBA2

● TOSHIBA is continually working to improve the quality and the reliability of its products. Nevertheless, semiconductor devices in general can malfunction or fail due to their inherent electrical sensitivity and vulnerability to physical stress. It is the responsibility of the buyer, when utilizing TOSHIBA products, to observe standards of safety, and to avoid situations in which a malfunction or failure of a TOSHIBA product could cause loss of human life, bodily injury or damage to property. In developing your designs, please ensure that TOSHIBA products are used within specified operating ranges as set forth in the most recent products specifications. Also, please keep in mind the precautions and conditions set forth in the TOSHIBA Semiconductor Reliability Handbook.

SYSTEM DIAGRAM

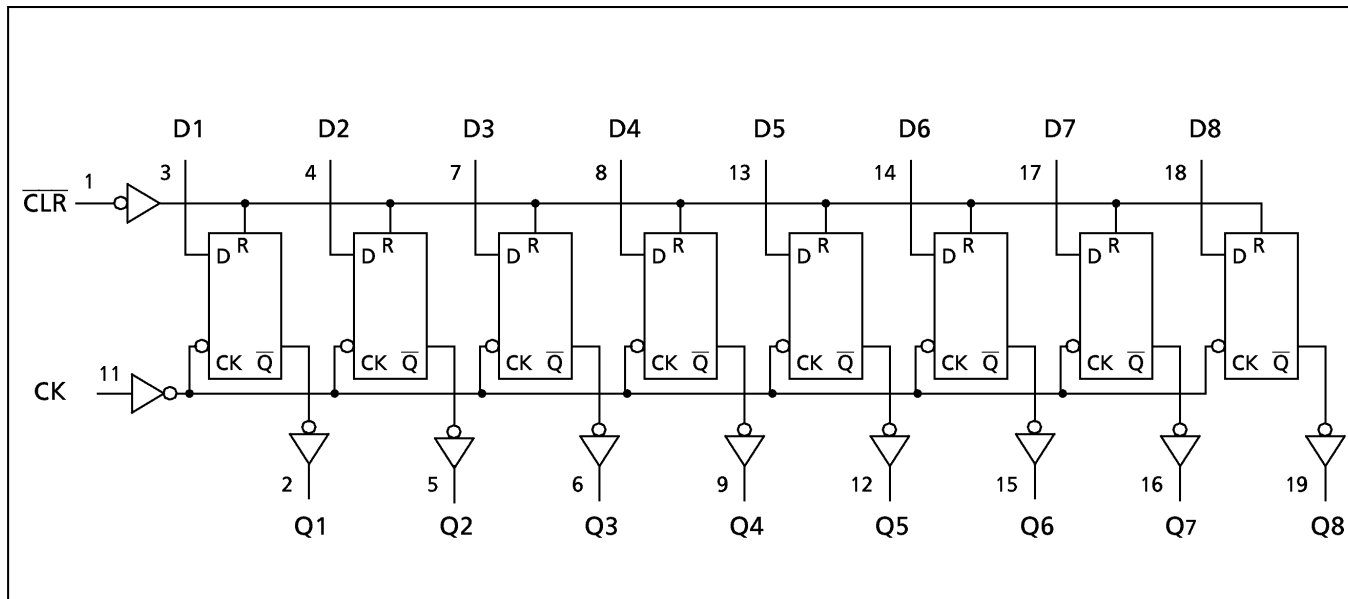

ABSOLUTE MAXIMUM RATINGS

PARAMETER	SYMBOL	VALUE	UNIT
Supply Voltage Range	V_{CC}	-0.5~7.0	V
DC Input Voltage	V_{IN}	-0.5~7.0	V
DC Output Voltage	V_{OUT}	-0.5~ $V_{CC} + 0.5$	V
Input Diode Current	I_{IK}	-20	mA
Output Diode Current	I_{OK}	±20	mA
DC Output Current	I_{OUT}	±25	mA
DC V_{CC} /Ground Current	I_{CC}	±75	mA
Power Dissipation	P_D	180	mW
Storage Temperature	T_{stg}	-65~150	°C

RECOMMENDED OPERATING CONDITIONS

PARAMETER	SYMBOL	VALUE	UNIT
Supply Voltage	V_{CC}	2.0~5.5	V
Input Voltage	V_{IN}	0~5.5	V
Output Voltage	V_{OUT}	0~ V_{CC}	V
Operating Temperature	T_{opr}	-40~85	°C
Input Rise and Fall Time	dt / dv	0~100 ($V_{CC} = 3.3 \pm 0.3V$) 0~20 ($V_{CC} = 5 \pm 0.5V$)	ns / V

980910EBA2'

- The products described in this document are subject to the foreign exchange and foreign trade laws.
- The information contained herein is presented only as a guide for the applications of our products. No responsibility is assumed by TOSHIBA CORPORATION for any infringements of intellectual property or other rights of the third parties which may result from its use. No license is granted by implication or otherwise under any intellectual property or other rights of TOSHIBA CORPORATION or others.
- The information contained herein is subject to change without notice.

DC ELECTRICAL CHARACTERISTICS

PARAMETER	SYMBOL	TEST CONDITION		V _{CC} (V)	Ta = 25°C			Ta = -40~85°C		UNIT
					MIN.	TYP.	MAX.	MIN.	MAX.	
High - Level Input Voltage	V _{IH}			2.0 3.0~ 5.5	1.50 V _{CC} ×0.7	— —	— —	1.50 V _{CC} ×0.7	— —	V
Low - Level Input Voltage	V _{IL}			2.0 3.0~ 5.5	— —	— —	0.50 V _{CC} ×0.3	— —	0.50 V _{CC} ×0.3	V
High - Level Output Voltage	V _{OH}	V _{IN} = V _{IH} or V _{IL}	I _{OH} = -50μA	2.0 3.0 4.5	1.9 2.9 4.4	2.0 3.0 4.5	— — —	1.9 2.9 4.4	— — —	V
			I _{OH} = -4mA I _{OH} = -8mA	3.0 4.5	2.58 3.94	— —	— —	2.48 3.80	— —	
Low - Level Output Voltage	V _{OL}	V _{IN} = V _{IH} or V _{IL}	I _{OL} = 50μA	2.0 3.0 4.5	— — —	0.0 0.0 0.0	0.1 0.1 0.1	— — —	0.1 0.1 0.1	V
			I _{OL} = 4mA I _{OL} = 8mA	3.0 4.5	— —	— —	0.36 0.36	— —	0.44 0.44	
Input Leakage Current	I _{IN}	V _{IN} = 5.5V or GND		0~5.5	—	—	±0.1	—	±1.0	μA
Quiescent Supply Current	I _{CC}	V _{IN} = V _{CC} or GND		5.5	—	—	4.0	—	40.0	

TIMING REQUIREMENTS (Input t_r = t_f = 3ns)

PARAMETER	SYMBOL	TEST CONDITION		V _{CC} (V)	Ta = 25°C		Ta = -40~85°C	UNIT
					TYP .	LIMIT	LIMIT	
Minimum Pulse Width (CK)	t _w (L) t _w (H)			3.3 ± 0.3	—	5.5	6.5	ns
				5.0 ± 0.5	—	5.0	5.0	
Minimum Pulse Width ($\overline{\text{CLR}}$)	t _w (L)			3.3 ± 0.3	—	5.0	6.0	
				5.0 ± 0.5	—	5.0	5.0	
Minimum Set - up Time	t _s			3.3 ± 0.3	—	5.5	6.5	
				5.0 ± 0.5	—	4.5	4.5	
Minimum Hold Time	t _h			3.3 ± 0.3	—	1.0	1.0	
				5.0 ± 0.5	—	1.0	1.0	
Minimum Removal Time ($\overline{\text{CLR}}$)	t _{rem}			3.3 ± 0.3	—	2.5	2.5	
				5.0 ± 0.5	—	2.0	2.0	

AC ELECTRICAL CHARACTERISTICS (Input $t_r = t_f = 3ns$)

PARAMETER	SYMBOL	TEST CONDITION	Ta = 25°C			Ta = -40~85°C		UNIT		
			V _{CC} (V)	CL (pF)	MIN.	TYP.	MAX.		MIN.	MAX.
Propagation Delay Time (CK-Q)	t _{pLH} t _{pHL}		3.3 ± 0.3	15	—	8.7	13.6	1.0	16.0	ns
				50	—	11.2	17.1	1.0	19.5	
	5.0 ± 0.5		15	—	5.8	9.0	1.0	10.5		
			50	—	7.3	11.0	1.0	12.5		
Propagation Delay Time (CLR-Q)	t _{pHL}		3.3 ± 0.3	15	—	8.9	13.6	1.0	16.0	
				50	—	11.4	17.1	1.0	19.5	
	5.0 ± 0.5		15	—	5.2	8.5	1.0	10.0		
			50	—	6.7	10.5	1.0	12.0		
Maximum Clock Frequency	f _{MAX}		3.3 ± 0.3	15	75	120	—	65	—	MHZ
				50	50	75	—	45	—	
			5.0 ± 0.5	15	120	165	—	100	—	
				50	80	110	—	70	—	
Output to Output Skew	t _{osLH} t _{osHL}	(Note 1)	3.3 ± 0.3	50	—	—	1.5	—	1.5	ns
			5.0 ± 0.5	50	—	—	1.0	—	1.0	
Input Capacitance	C _{IN}				—	4	10	—	10	pF
Power Dissipation Capacitance	C _{PD}	(Note 2)			—	31	—	—	—	

Note (1) Parameter guaranteed by design. $t_{osLH} = |t_{pLHm} - t_{pLHn}|$, $t_{osHL} = |t_{pHLm} - t_{pHLn}|$

Note (2) C_{PD} is defined as the value of the internal equivalent capacitance which is calculated from the operating current consumption without load.

Average operating current can be obtained by the equation :

$$I_{CC(opr.)} = C_{PD} \cdot V_{CC} \cdot f_{IN} + I_{CC}/8 \text{ (per F/F)}$$

And the total C_{PD} when n pcs. of Flip Flop operate can be gained by the following equation :

$$C_{PD} \text{ (total)} = 22 + 9 \cdot n$$

NOISE CHARACTERISTICS (Input $t_r = t_f = 3ns$)

PARAMETER	SYMBOL	TEST CONDITION	Ta = 25°C			UNIT
			V _{CC} (V)	TYP.	MAX.	
Quiet Output Maximum Dynamic V _{OL}	V _{OLP}	C _L = 50pF	5.0	0.5 (0.6)	0.8 (0.9)	V
Quiet Output Minimum Dynamic V _{OL}	V _{OLV}	C _L = 50pF	5.0	-0.5 (-0.6)	-0.8 (-0.9)	V
Minimum High Level Dynamic Input Voltage	V _{IHD}	C _L = 50pF	5.0	—	3.5	V
Maximum Low Level Dynamic Input Voltage	V _{ILD}	C _L = 50pF	5.0	—	1.5	V

(Note) The value in () only applies to JEDEC SOP (FW) devices.

INPUT EQUIVALENT CIRCUIT

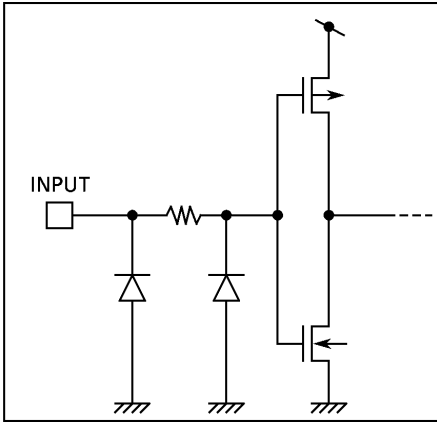

SOP 20PIN (200mil BODY) PACKAGE DIMENSIONS (SOP20-P-300-1.27)

Unit in mm

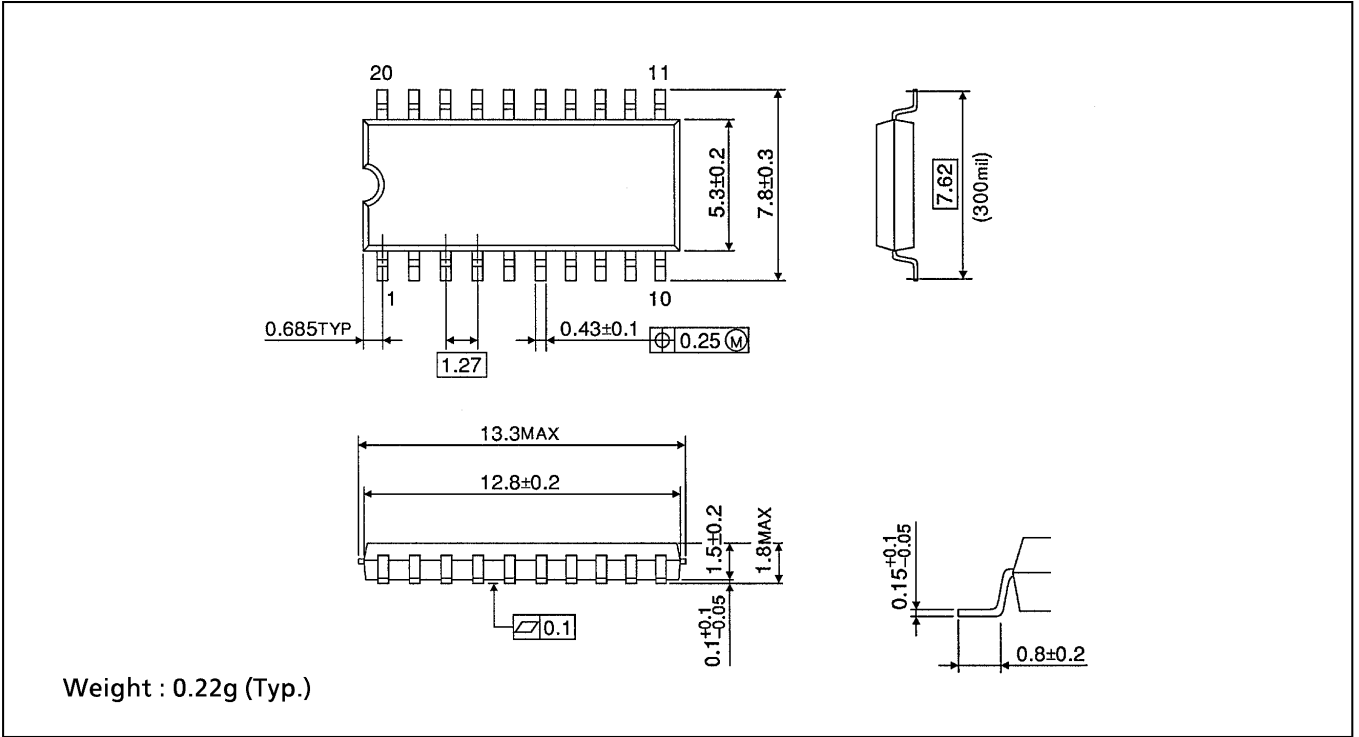

SOP 20PIN (300mil BODY) PACKAGE DIMENSIONS (SOP20-P-300-1.27)

Unit in mm

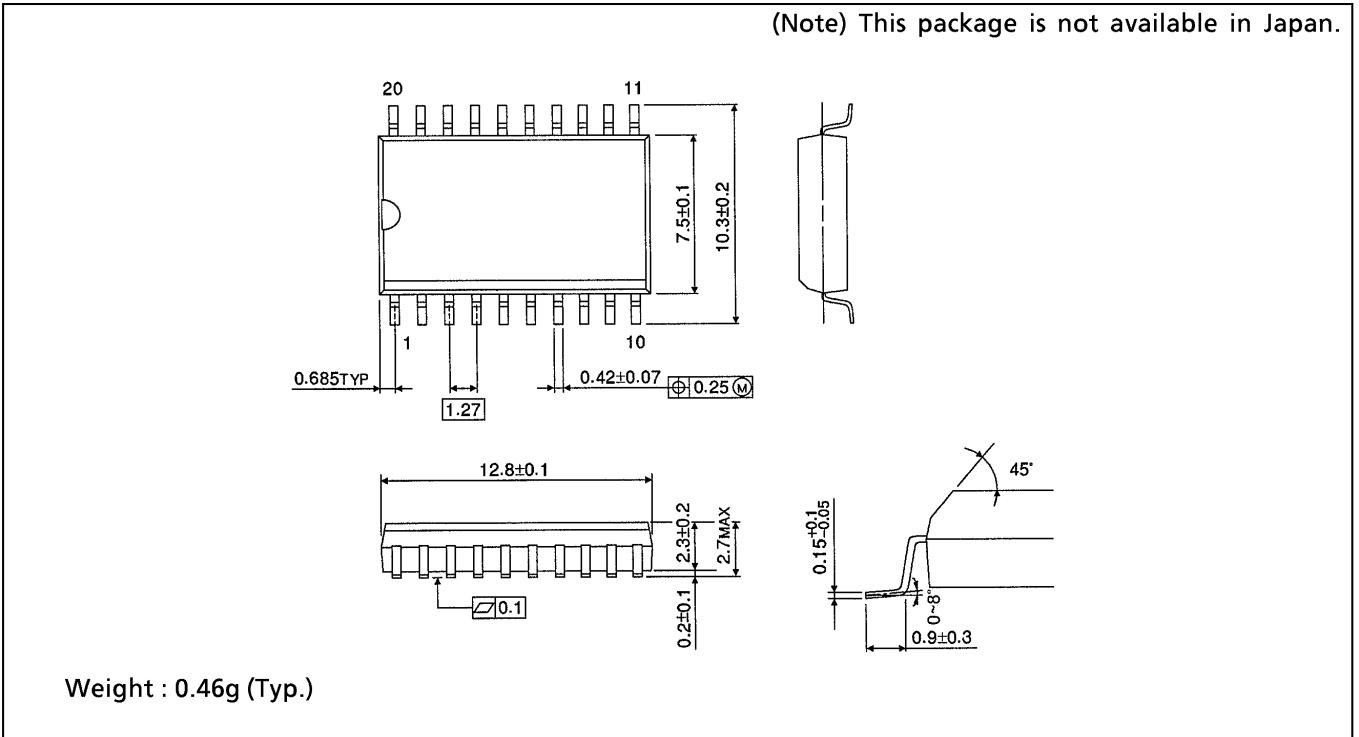

TSSOP 20PIN PACKAGE DIMENSIONS (TSSOP20-P-0044-0.65)

Unit in mm

