

DATA SHEET

For a complete data sheet, please also download:

- The IC04 LOCMOS HE4000B Logic Family Specifications HEF, HEC
- The IC04 LOCMOS HE4000B Logic Package Outlines/Information HEF, HEC

HEF4029B

MSI

Synchronous up/down counter,
binary/decade counter

Product specification
File under Integrated Circuits, IC04

January 1995

**Synchronous up/down counter,
binary/decade counter**

**HEF4029B
MSI**

DESCRIPTION

The HEF4029B is a synchronous edge-triggered up/down 4-bit binary/BCD decade counter with a clock input (CP), an active LOW count enable input (\overline{CE}), an up/down control input ($\overline{UP/DN}$), a binary/decade control input ($\overline{BIN/DEC}$), an overriding asynchronous active HIGH parallel load input (PL), four parallel data inputs (P_0 to P_3), four parallel buffered outputs (O_0 to O_3) and an active LOW terminal count output (\overline{TC}).

Information on P_0 to P_3 is asynchronously loaded into the counter while PL is HIGH, independent of CP.

The counter is advanced one count on the LOW to HIGH transition of CP when \overline{CE} and PL are LOW. The \overline{TC} signal is normally HIGH and goes LOW when the counter reaches its maximum count in the UP mode, or the minimum count in the DOWN mode provided \overline{CE} is LOW.

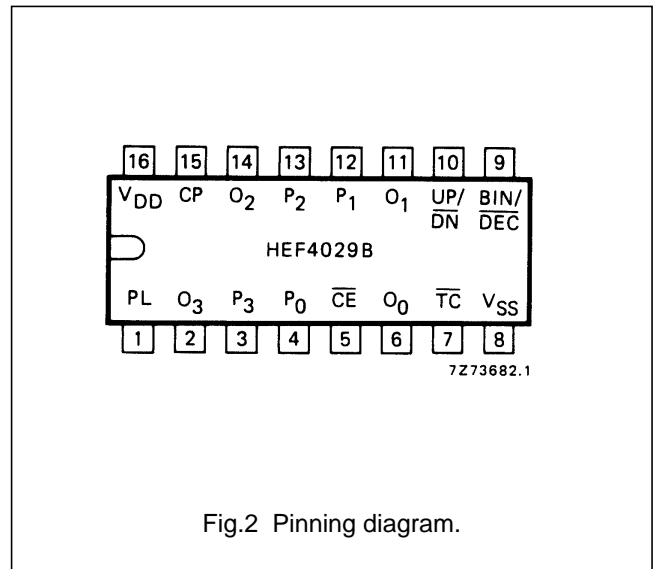
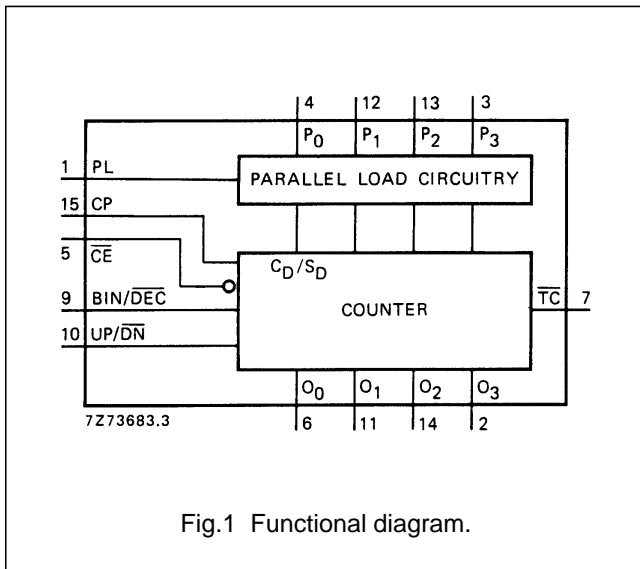

- HEF4029BP(N): 16-lead DIL; plastic (SOT38-1)
- HEF4029BD(F): 16-lead DIL; ceramic (cerdip) (SOT74)
- HEF4029BT(D): 16-lead SO; plastic (SOT109-1)
- (): Package Designator North America

PINNING

- PL parallel load input
- P_0 to P_3 parallel data inputs
- $\overline{BIN/DEC}$ binary/decade control input
- $\overline{UP/DN}$ up/down control input
- \overline{CE} count enable input (active LOW)
- CP clock input (LOW to HIGH, edge triggered)
- O_0 to O_3 buffered parallel outputs
- \overline{TC} terminal count output (active LOW)

FAMILY DATA, I_{DD} LIMITS category MSI

See Family Specifications

Synchronous up/down counter,
binary/decade counter

HEF4029B
MSI

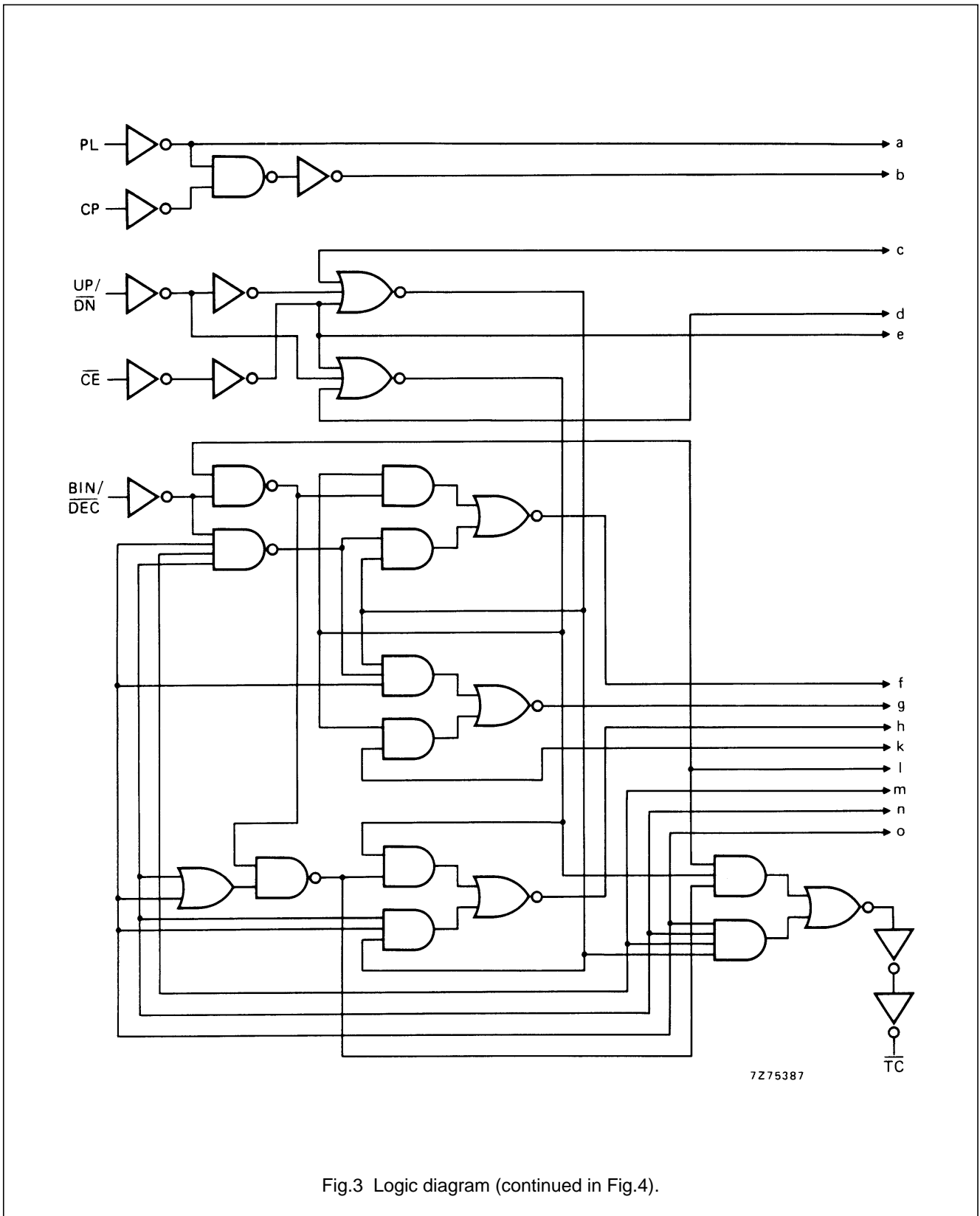
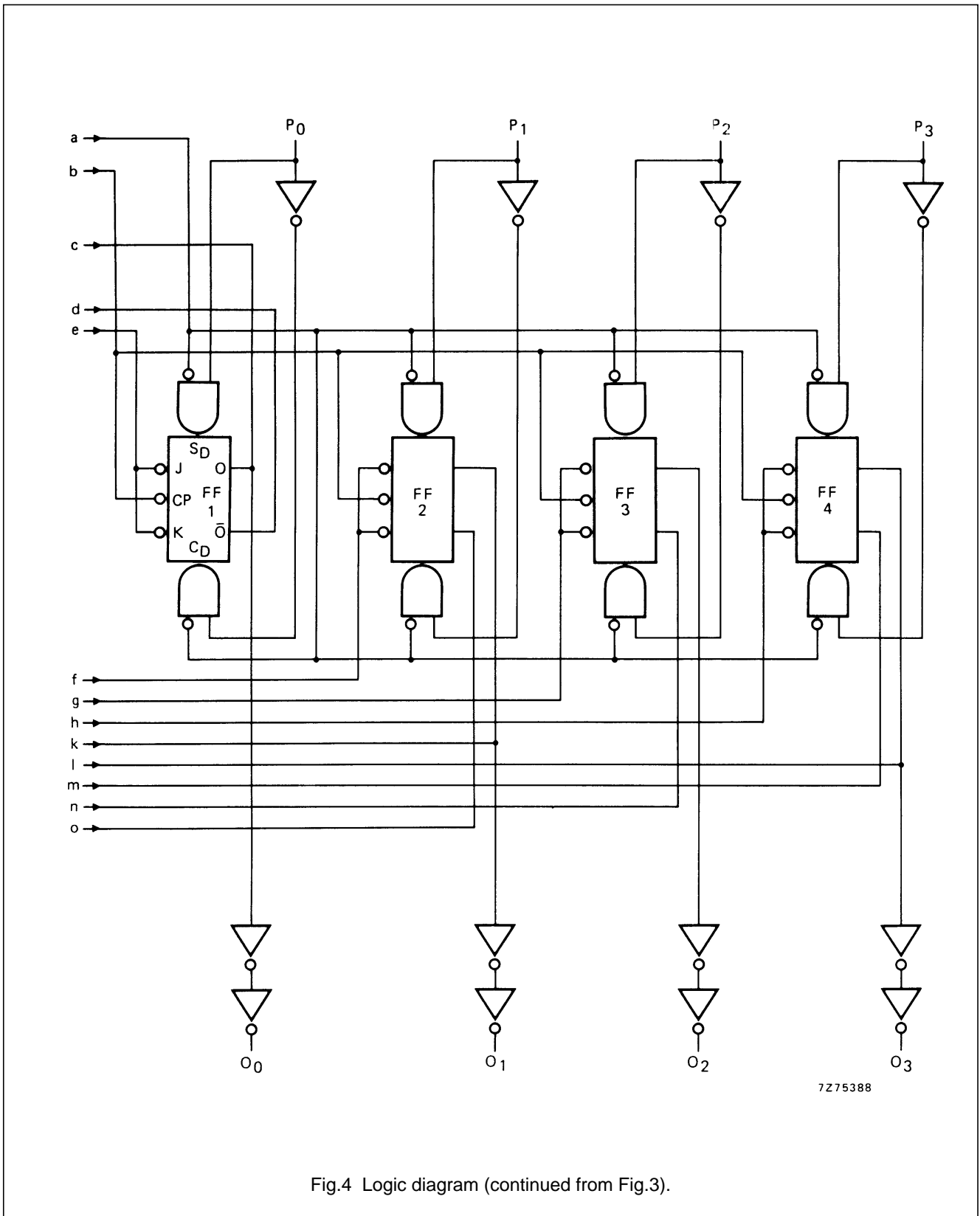

Fig.3 Logic diagram (continued in Fig.4).

Synchronous up/down counter,
binary/decade counter

HEF4029B
MSI



Synchronous up/down counter,
binary/decade counter

HEF4029B
MSI

FUNCTION TABLE

PL	BIN/DEC	UP/DN	CE	CP	MODE
H	X	X	X	X	parallel load ($P_n \rightarrow O_n$)
L	X	X	H	X	no change
L	L	L	L	↗	count-down, decade
L	L	H	L	↗	count-up, decade
L	H	L	L	↗	count-down, binary
L	H	H	L	↗	count-up, binary

Notes

- H = HIGH state (the more positive voltage)
L = LOW state (the less positive voltage)
X = state is immaterial
↗ = positive-going clock pulse edge

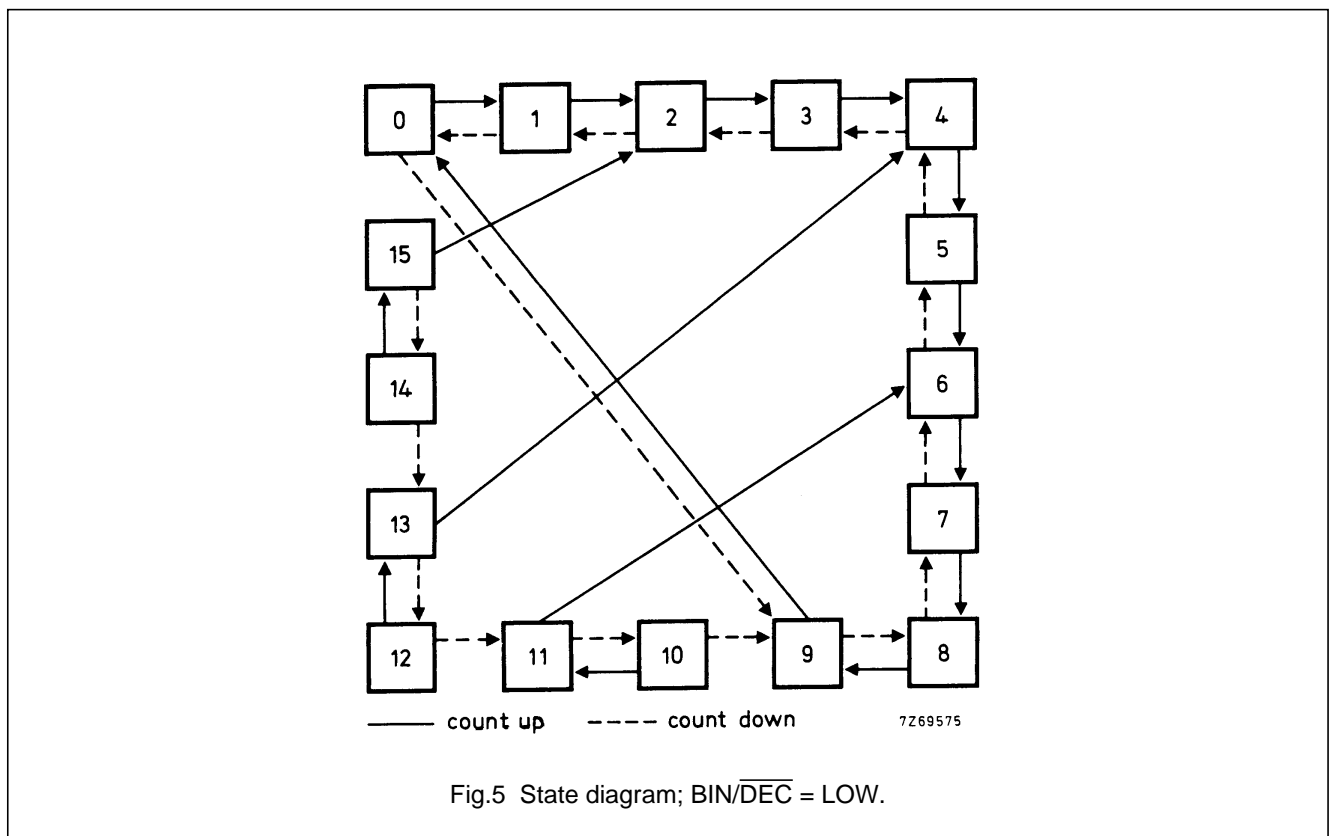

Synchronous up/down counter,
binary/decade counter

HEF4029B
MSI

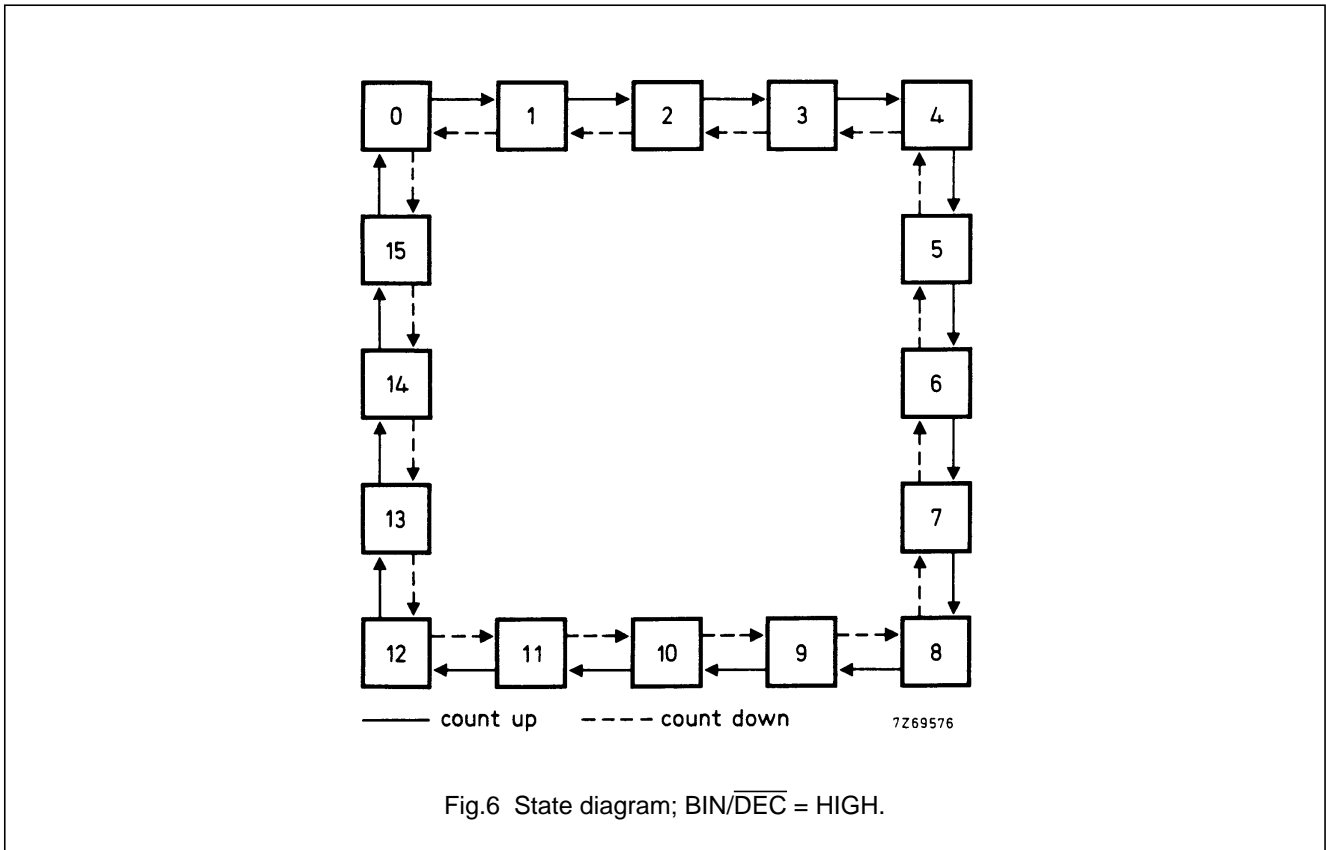

Logic equation for terminal count:

$$TC = \overline{CE} (\overline{BIN/\overline{DEC}} \cdot \overline{UP/\overline{DN}} \cdot O_0 \cdot O_1 \cdot O_2 \cdot O_3 + \overline{BIN/\overline{DEC}} \cdot \overline{UP/\overline{DN}} \cdot \overline{O_0} \cdot \overline{O_1} \cdot \overline{O_2} \cdot \overline{O_3} + \overline{BIN/\overline{DEC}} \cdot \overline{UP/\overline{DN}} \cdot O_0 \cdot O_3 + \overline{BIN/\overline{DEC}} \cdot \overline{UP/\overline{DN}} \cdot \overline{O_0} \cdot \overline{O_1} \cdot \overline{O_2} \cdot \overline{O_3})$$

Synchronous up/down counter, binary/decade counter

HEF4029B MSI

AC CHARACTERISTICS

$V_{SS} = 0$ V; $T_{amb} = 25$ °C; input transition times ≤ 20 ns

	V_{DD} V	TYPICAL FORMULA FOR P (μ W)	
Dynamic power dissipation per package (P)	5 10 15	$1000 f_i + \sum(f_o C_L) \times V_{DD}^2$ $4500 f_i + \sum(f_o C_L) \times V_{DD}^2$ $11\,500 f_i + \sum(f_o C_L) \times V_{DD}^2$	where f_i = input freq. (MHz) f_o = output freq. (MHz) C_L = load capacitance (pF) $\sum(f_o C_L)$ = sum of outputs V_{DD} = supply voltage (V)

AC CHARACTERISTICS

$V_{SS} = 0$ V; $T_{amb} = 25$ °C; $C_L = 50$ pF; input transition times ≤ 20 ns

	V_{DD} V	SYMBOL	MIN.	TYP.	MAX.	TYPICAL EXTRAPOLATION FORMULA		
Propagation delays CP \rightarrow O _n HIGH to LOW	5	t _{PHL}		145	290	ns	118 ns + (0,55 ns/pF) C _L	
	10		55	110	ns	44 ns + (0,23 ns/pF) C _L		
	15		40	75	ns	32 ns + (0,16 ns/pF) C _L		
	LOW to HIGH	5	t _{PLH}		160	315	ns	133 ns + (0,55 ns/pF) C _L
		10		60	120	ns	49 ns + (0,23 ns/pF) C _L	
		15		40	80	ns	32 ns + (0,16 ns/pF) C _L	
CP \rightarrow \overline{TC} HIGH to LOW	5	t _{PHL}		280	560	ns	253 ns + (0,55 ns/pF) C _L	
	10		105	205	ns	94 ns + (0,23 ns/pF) C _L		
	15		70	140	ns	62 ns + (0,16 ns/pF) C _L		
	LOW to HIGH	5	t _{PLH}		195	385	ns	168 ns + (0,55 ns/pF) C _L
		10		75	150	ns	64 ns + (0,23 ns/pF) C _L	
		15		55	105	ns	47 ns + (0,16 ns/pF) C _L	
PL \rightarrow O _n HIGH to LOW	5	t _{PHL}		120	240	ns	93 ns + (0,55 ns/pF) C _L	
	10		50	100	ns	39 ns + (0,23 ns/pF) C _L		
	15		35	70	ns	27 ns + (0,16 ns/pF) C _L		
	LOW to HIGH	5	t _{PLH}		170	335	ns	143 ns + (0,55 ns/pF) C _L
		10		65	130	ns	54 ns + (0,23 ns/pF) C _L	
		15		45	90	ns	37 ns + (0,16 ns/pF) C _L	
$\overline{CE} \rightarrow \overline{TC}$ HIGH to LOW	5	t _{PHL}		180	360	ns	153 ns + (0,55 ns/pF) C _L	
	10		70	140	ns	59 ns + (0,23 ns/pF) C _L		
	15		50	100	ns	42 ns + (0,16 ns/pF) C _L		
	LOW to HIGH	5	t _{PLH}		170	335	ns	143 ns + (0,55 ns/pF) C _L
		10		65	135	ns	54 ns + (0,23 ns/pF) C _L	
		15		50	100	ns	42 ns + (0,16 ns/pF) C _L	

Synchronous up/down counter,
binary/decade counter

HEF4029B
MSI

	V _{DD} V	SYMBOL	MIN.	TYP.	MAX.		TYPICAL EXTRAPOLATION FORMULA
Output transition times HIGH to LOW	5	t _{THL}		60	120	ns	10 ns + (1,0 ns/pF) C _L
	10			30	60	ns	9 ns + (0,42 ns/pF) C _L
	15			20	40	ns	6 ns + (0,28 ns/pF) C _L
LOW to HIGH	5	t _{TLH}		60	120	ns	10 ns + (1,0 ns/pF) C _L
	10			30	60	ns	9 ns + (0,42 ns/pF) C _L
	15			20	40	ns	6 ns + (0,28 ns/pF) C _L

Synchronous up/down counter,
binary/decade counterHEF4029B
MSI

AC CHARACTERISTICS

 $V_{SS} = 0\text{ V}$; $T_{amb} = 25\text{ }^{\circ}\text{C}$; $C_L = 50\text{ pF}$; input transition times $\leq 20\text{ ns}$

	V_{DD} V	SYMBOL	MIN	TYP	MAX	
Minimum clock pulse width; LOW	5	t_{WCPL}	110	55	ns	see also waveforms Figs 7 and 8
	10		35	20	ns	
	15		25	15	ns	
Minimum PL pulse width; HIGH	5	t_{WPLH}	160	80	ns	
	10		55	25	ns	
	15		35	15	ns	
Recovery time for PL	5	t_{RPL}	150	75	ns	
	10		50	25	ns	
	15		35	20	ns	
Set-up times $\overline{\text{BIN/DEC}} \rightarrow \text{CP}$	5	t_{su}	270	135	ns	
	10		90	45	ns	
	15		60	30	ns	
$\text{UP}/\overline{\text{DN}} \rightarrow \text{CP}$	5	t_{su}	300	150	ns	
	10		105	55	ns	
	15		75	35	ns	
$\overline{\text{CE}} \rightarrow \text{CP}$	5	t_{su}	240	120	ns	
	10		90	50	ns	
	15		70	40	ns	
$P_n \rightarrow \text{PL}$	5	t_{su}	70	35	ns	
	10		20	10	ns	
	15		10	5	ns	
Hold times $\overline{\text{BIN/DEC}} \rightarrow \text{CP}$	5	t_{hold}	45	-90	ns	
	10		15	-30	ns	
	15		10	-20	ns	
$\text{UP}/\overline{\text{DN}} \rightarrow \text{CP}$	5	t_{hold}	15	-135	ns	
	10		0	-50	ns	
	15		-5	-35	ns	
$\overline{\text{CE}} \rightarrow \text{CP}$	5	t_{hold}	30	-30	ns	
	10		10	-10	ns	
	15		5	-10	ns	
$P_n \rightarrow \text{PL}$	5	t_{hold}	15	-20	ns	
	10		0	-10	ns	
	15		0	-5	ns	
Maximum clock pulse frequency	5	f_{max}	2	4	MHz	
	10		5	10	MHz	
	15		8	15	MHz	

Synchronous up/down counter,
binary/decade counter

HEF4029B
MSI

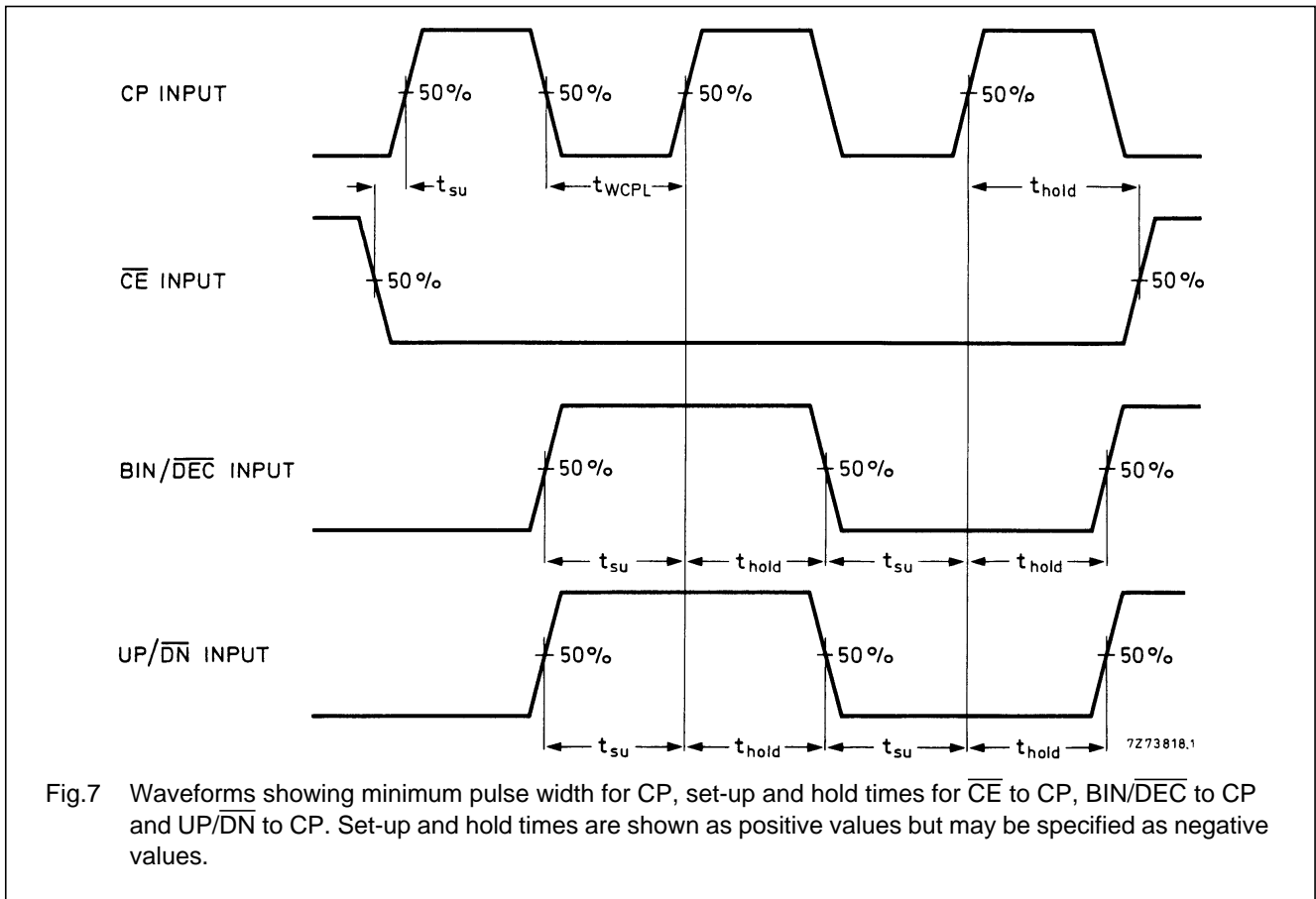

Fig.7 Waveforms showing minimum pulse width for CP, set-up and hold times for \overline{CE} to CP, BIN/ \overline{DEC} to CP and UP/ \overline{DN} to CP. Set-up and hold times are shown as positive values but may be specified as negative values.

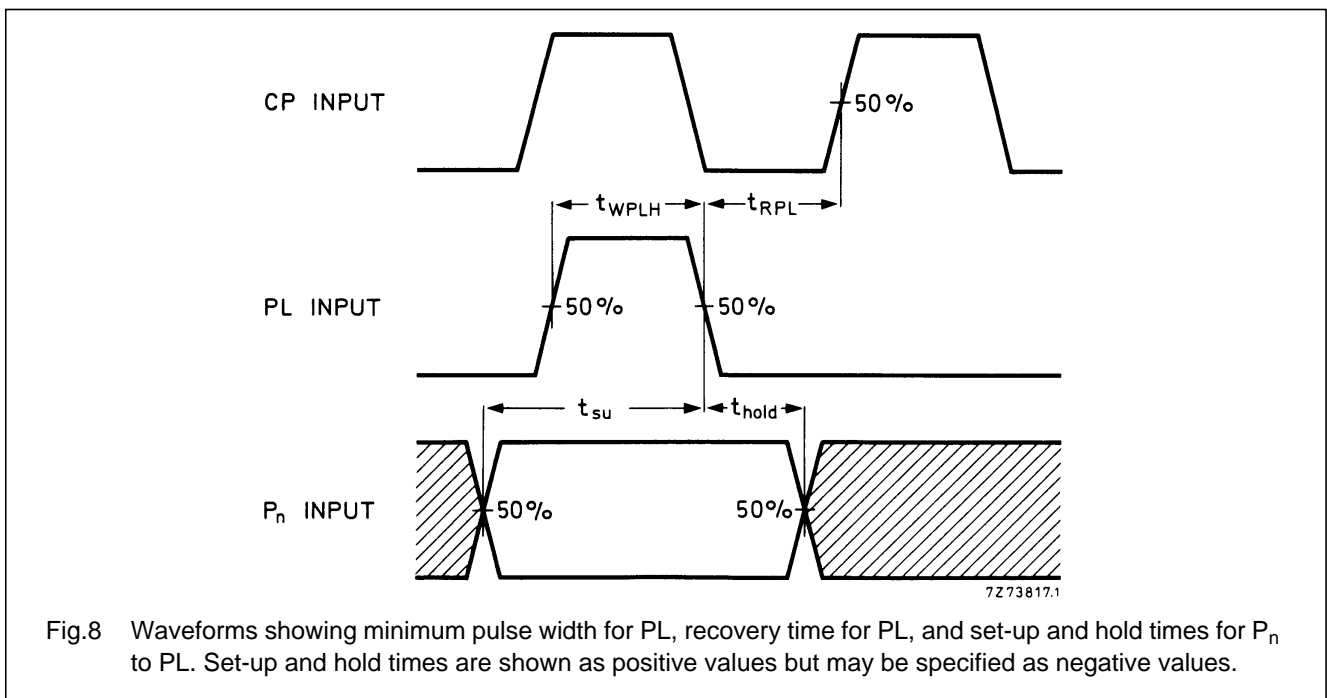
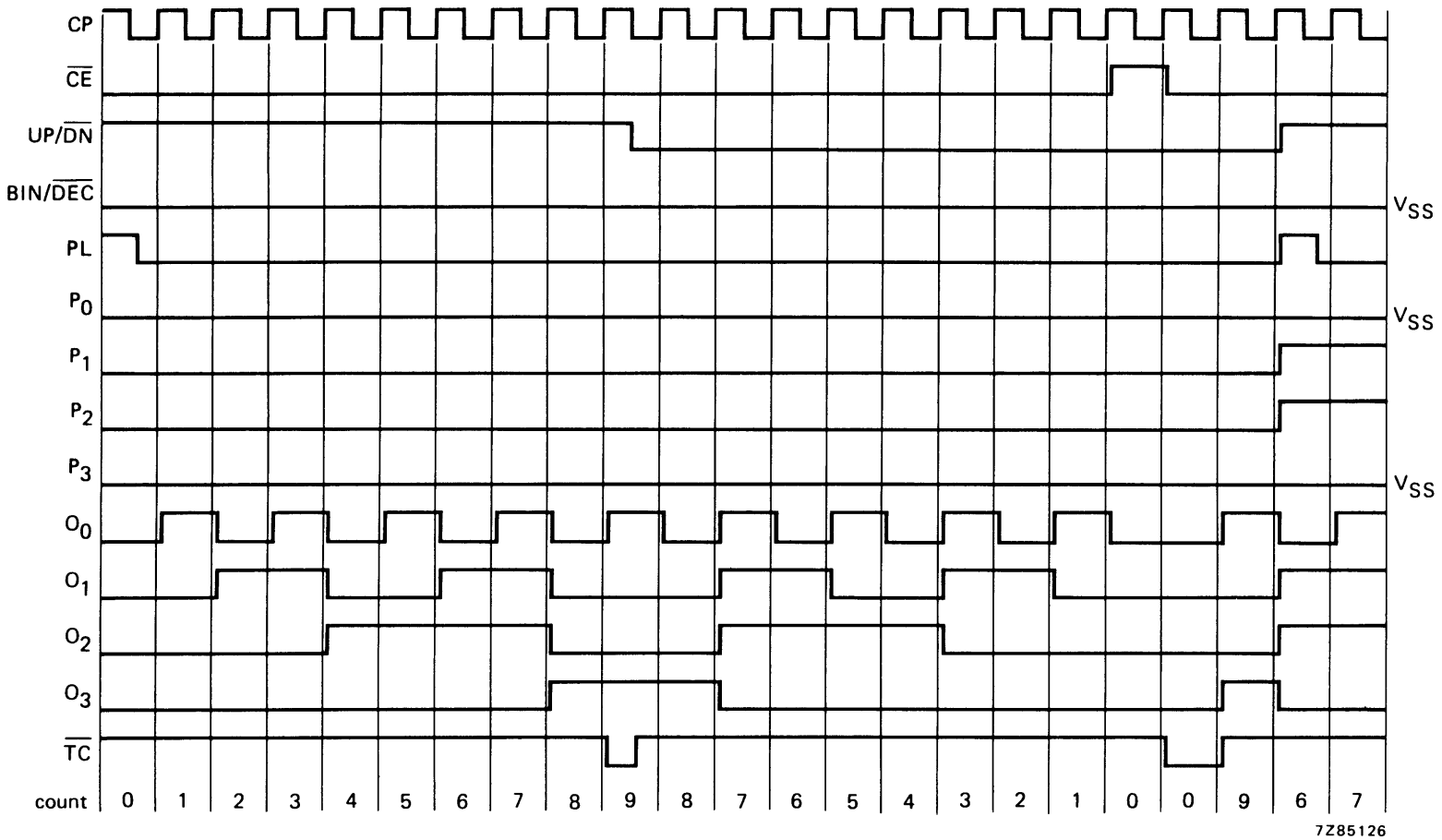

Fig.8 Waveforms showing minimum pulse width for PL, recovery time for PL, and set-up and hold times for P_n to PL. Set-up and hold times are shown as positive values but may be specified as negative values.

Synchronous up/down counter,
binary/decade counter

HEF4029B
MSI



7Z85126

Fig.9 Timing diagram; decade mode; P₀ = LOW; P₃ = LOW; BIN/DEC = LOW.

Synchronous up/down counter,
binary/decade counter

HEF4029B
MSI

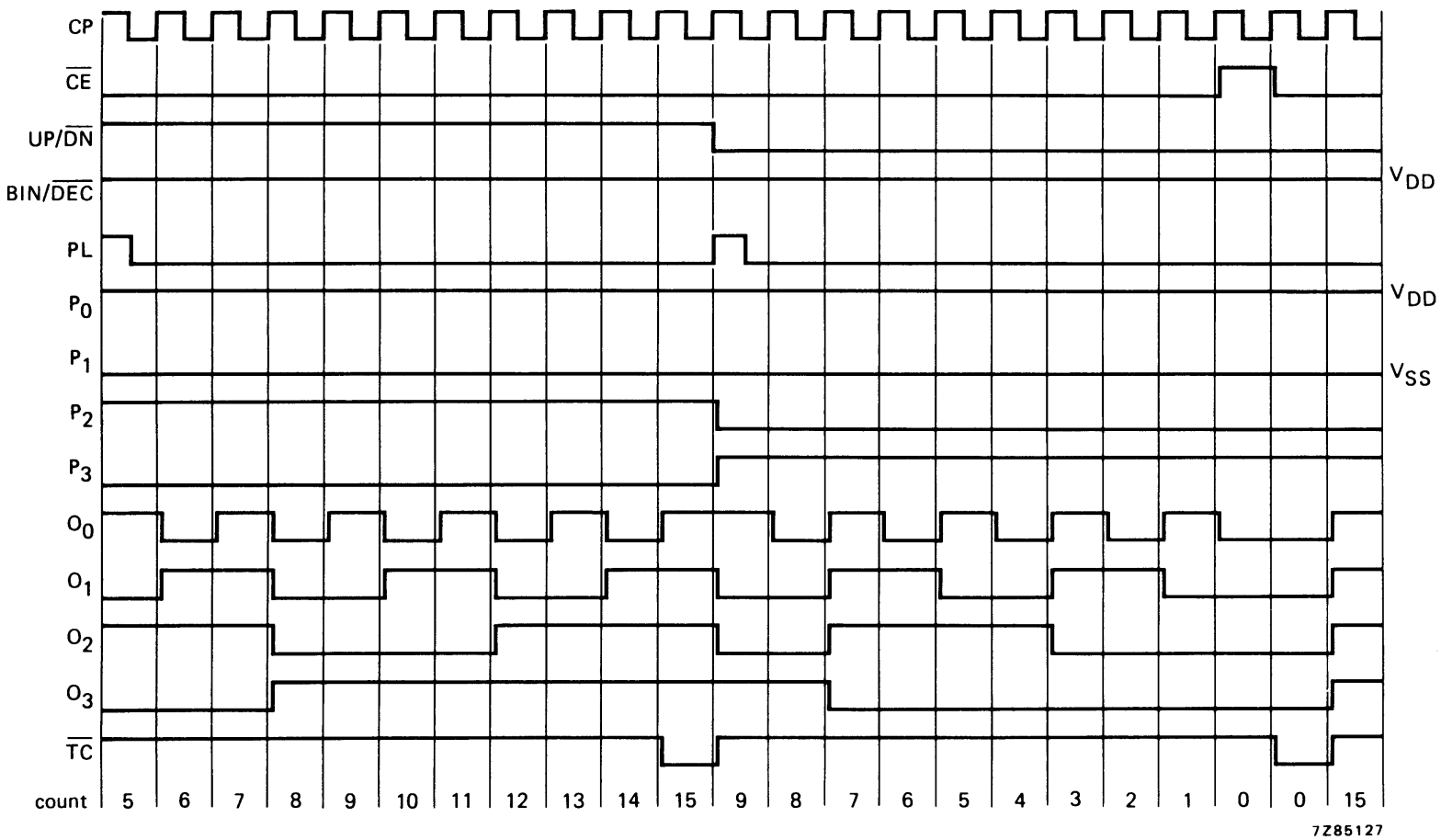

Fig.10 Timing diagram; binary mode; P₀ = HIGH; P₁ = LOW; BIN/DEC = HIGH.

7285127

Synchronous up/down counter,
binary/decade counter

HEF4029B
MSI

APPLICATION INFORMATION

Some examples of applications for the HEF4029B are:

- Programmable binary and decade counting/frequency synthesizers - BCD output.
- Analogue-to-digital and digital-to-analogue conversion.
- Up/down binary counting.
- Magnitude and sign generation.
- Up/down decade counting.
- Difference counting.

Synchronous up/down counter,
binary/decade counter

HEF4029B
MSI

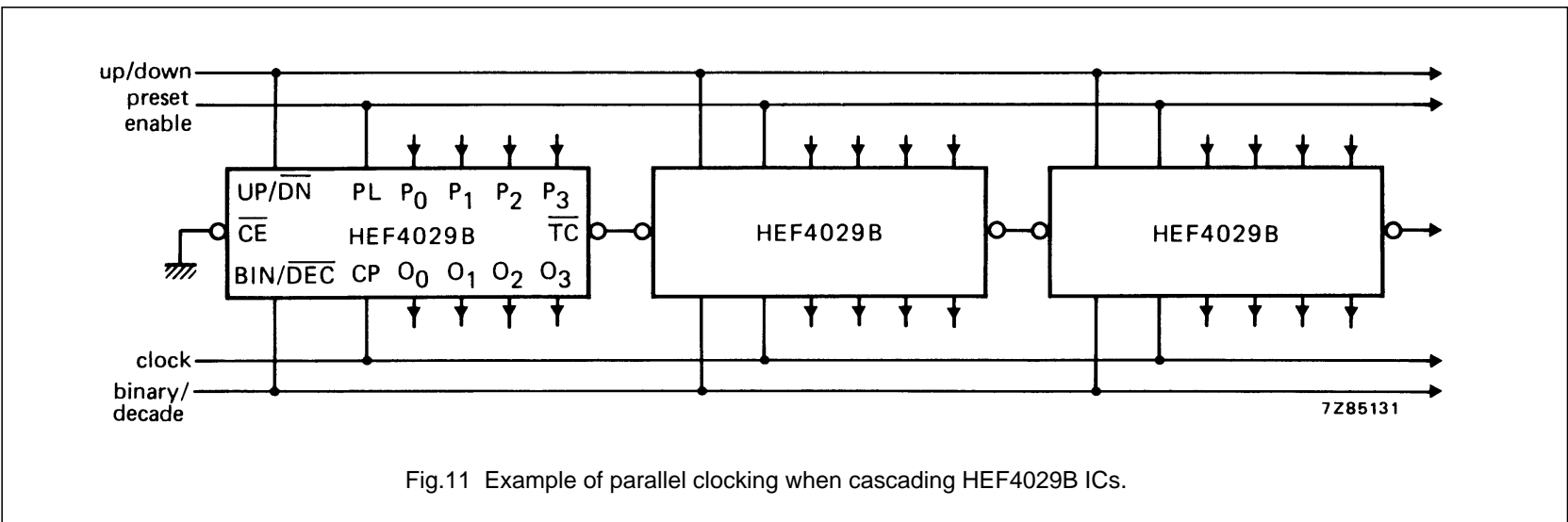
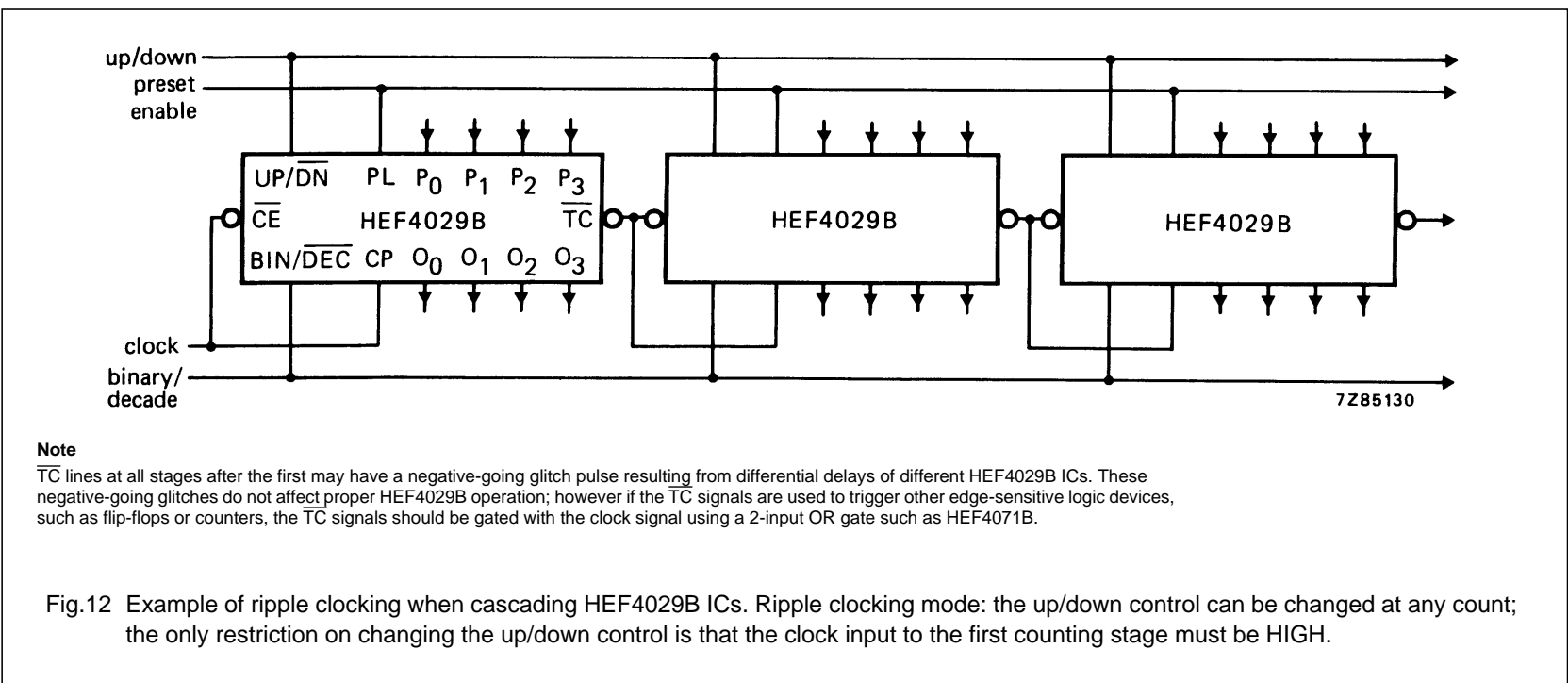

Fig.11 Example of parallel clocking when cascading HEF4029B ICs.



Note

\overline{TC} lines at all stages after the first may have a negative-going glitch pulse resulting from differential delays of different HEF4029B ICs. These negative-going glitches do not affect proper HEF4029B operation; however if the \overline{TC} signals are used to trigger other edge-sensitive logic devices, such as flip-flops or counters, the \overline{TC} signals should be gated with the clock signal using a 2-input OR gate such as HEF4071B.

Fig.12 Example of ripple clocking when cascading HEF4029B ICs. Ripple clocking mode: the up/down control can be changed at any count; the only restriction on changing the up/down control is that the clock input to the first counting stage must be HIGH.