

Power driver for CD and MD applications

BH6514AFS

The BH6514AFS is a PWM driver for CD and MD motors and actuators.

In addition to a two-channel "H" bridge for the actuators, the IC includes a three-phase driver for spindle motor drive, and a single-channel half bridge for synchronous rectification of the spindle drive V_M .

● Applications

Power drive for CD and MD players

● Features

- 1) Compatible with PWM input.
- 2) Charge pump circuit to increase V_G .
- 3) Charge pump circuit has free-running oscillator.
- 4) Each "H" bridge power supply can be supplied independently for efficient application.
- 5) Low on-resistance.
- 6) Low power consumption.
- 7) Compact SSOP-A32 package.

● Absolute maximum ratings ($T_a = 25^\circ\text{C}$)

Parameter	Symbol	Limits	Unit
H-bridge power supply voltage	V_M	9	V
Control circuit power supply voltage	VDD	9	V
Pre-driver power supply voltage	V_G (18pin)	12	V
Driver output current	I_o (ch3, U, V, Wch) I_o (ch1, ch2)	500 300*1	mA
Power dissipation	P_d	850*2	mW
Operating temperature	T_{opr}	$-20 \sim +85$	$^\circ\text{C}$
Storage temperature	T_{stg}	$-55 \sim +150$	$^\circ\text{C}$

*1 500msec.

*2 Reduced by 6.8mW for each increase in T_a of 1°C over 25°C .

● Recommended operating conditions ($T_a = 25^\circ\text{C}$)

Parameter	Symbol	Min.	Typ.	Max.	Unit
H-bridge power supply voltage	V_M	1.6	2.5	5.5	V
Control circuit power supply voltage	VDD	2.4*3	3.0	5.5	V
Pre-driver power supply voltage	V_G (18pin)	$V_M + 3.0$	9	11.5	V
Pulse input frequency	f_{123IN}	—	176.4	200	kHz
	F_{UVWMIN}	—	—	400	Hz

*3 When the ambient temperature is in the range -20°C to 85°C .

●Block diagram

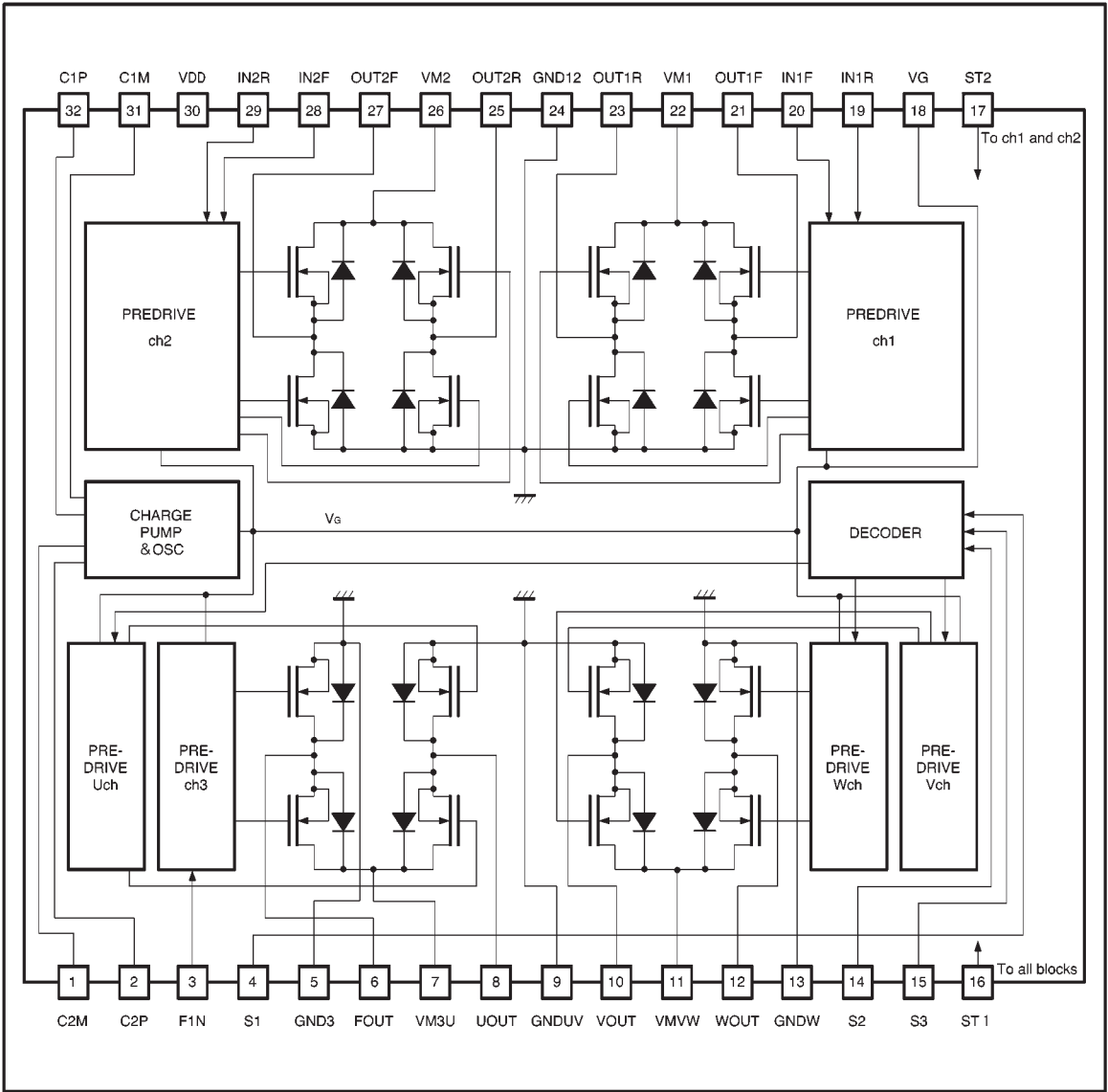

● Pin descriptions

Pin No.	Pin name	Function	Pin No.	Pin name	Function
1	C2M	Negative connection terminal for charge pump capacitor 2	32	C1P	Positive connection terminal for charge pump capacitor 1
2	C2P	Positive connection terminal for charge pump capacitor 2	31	C1M	Negative connection terminal for charge pump capacitor 1
3	FIN	Brushless motor power supply input	30	VDD	Pre block power supply
4	S1	Stepping motor input	29	IN2R	Channel 2 reverse input
5	GND3	Channel 3 power GND	28	IN2F	Channel 2 forward input
6	FOUT	Brushless motor power supply output	27	OUT2F	Channel 2 forward output
7	VM3U	Channel 3, U channel power block power supply	26	VM2	Channel 2 power block power supply
8	UOUT	Stepping motor output (U phase)	25	OUT2R	Channel 2 reverse output
9	GNDUV	U channel, V channel power GND	24	GND12	Channel 1,2 power GND
10	VOUT	Stepping motor output (V phase)	23	OUT1R	Channel 1 reverse output
11	VMVW	V channel, W channel power block power supply	22	VM1	Channel 1 power block power supply
12	WOOUT	Stepping motor output (W phase)	21	OUT1F	Channel 1 forward output
13	GNDW	W channel power GND	20	IN1F	Channel 1 forward input
14	S2	Stepping motor input	19	IN1R	Channel 1 reverse input
15	S3	Stepping motor input	18	VG	Charge pump output
16	ST1	Standby	17	ST2	Channels 1 and 2 mute

● Input / output circuits

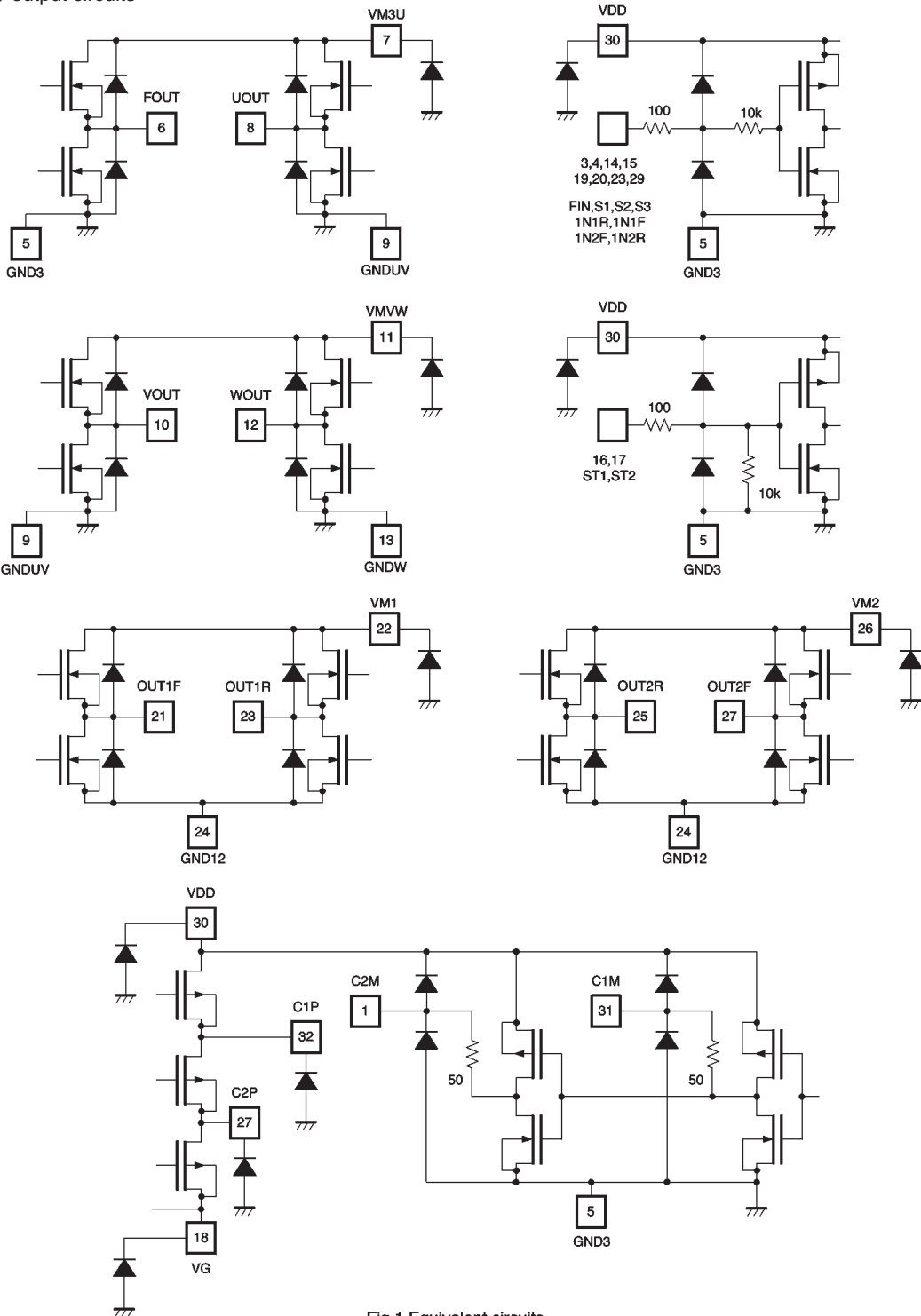

Fig.1 Equivalent circuits

- Electrical characteristics (unless otherwise noted, $T_a = 25^\circ\text{C}$, $V_M = 2.5\text{V}$, $V_{DD} = 3\text{V}$,
 VG is the internally pumped output, $f_{123\text{IN}} = 176\text{kHz}$, $f_{UVWIN} = 1\text{kHz}$, and $R_L = 8\Omega\text{--}47\mu\text{H}$)

Parameter	Symbol	Min.	Typ.	Max.	Unit	Conditions
〈H-bridge power supply current〉						
No input	I_{MST}	—	—	1	μA	—
〈Control circuit power supply current〉						
Standby	I_{DDST}	—	—	1	μA	ST1=L
No signal	I_{DDO}	—	0.6	1	mA	ST2=low level, all inputs low level
Operation	I_{DDA}	—	3.1	6.5	mA	ST1 and ST2=high level, all channels driven together
〈Pre-drive power supply voltage〉						
No input	I_{G1}	7.5	8.9	10	V	ST1 and ST2=high level, all inputs low level
Operation	I_{G2}	6.0	7.6	9.5	V	ST1 and ST2=high level, all channels driven together
〈Logic input characteristics〉						
Input high level voltage	V_{IH}	$V_{DD}-0.6$	—	—	V	—
Input low level voltage	V_{IL}	—	—	0.6	V	—
Input high level current 1	I_{IH1}	—	—	1	μA	$V_{IN}=3\text{V}$, each driver input
Input low level current 1	I_{IL1}	-1	—	—	μA	$V_{IN}=0\text{V}$, each driver input
Input high level current 2	I_{IH2}	—	300	600	μA	$V_{IN}=3\text{V}$, ST1 and ST2 pins
Input low level current 2	I_{IL2}	-1	—	—	μA	$V_{IN}=0\text{V}$, ST1 and ST2 pins
Output on-resistance	R_{ON3UVW}	—	0.8	1.2	Ω	Sum of top and bottom resistors
	R_{ON12}	—	1.2	2.0	Ω	VG=10V
Output transmission delay time 1	t_{RISE}	—	0.2	1	μsec	ch1, ch2, ch3
	t_{FALL}	—	0.2	1	μsec	
Output transmission delay time 2	t_{EDGE}	—	0.3	20	μsec	Uch, Vch, Wch
Minimum input pulse width	t_{min}	200	—	—	nsec	Output pulse width 2 / 3 t_{Min} . or more
〈Oscillator circuit〉						
Free-running frequency	f_{osc}	150	300	400	kHz	Pin 32 waveform monitor

©Not designed for radiation resistance.

● Circuit operation

Driver truth table

Focus / tracking coil

ST1	ST2	IN1, 2F	IN1, 2R	OUT1, 2F	OUT1, 2R
H	H	L	L	L	L
H	H	L	H	L	H
H	H	H	L	H	L
H	H	H	H	L	L
L	X	X	X	Z	Z
X	L	X	X	Z	Z

Brushless motor power supply

ST1	ST2	FIN	F _{OUT}
H	X	L	L
H	X	H	H
L	X	X	Z

Stepping motor

ST1	ST2	S3	S2	S1	U _{OUT}	V _{OUT}	W _{OUT}
H	X	L	L	L	H	L	Z
H	X	L	L	H	H	Z	L
H	X	L	H	L	Z	H	L
H	X	L	H	H	L	H	Z
H	X	H	L	L	L	Z	H
H	X	H	L	H	Z	L	H
H	X	H	H	X	Z	Z	Z
L	X	X	X	X	Z	Z	Z

●Application example

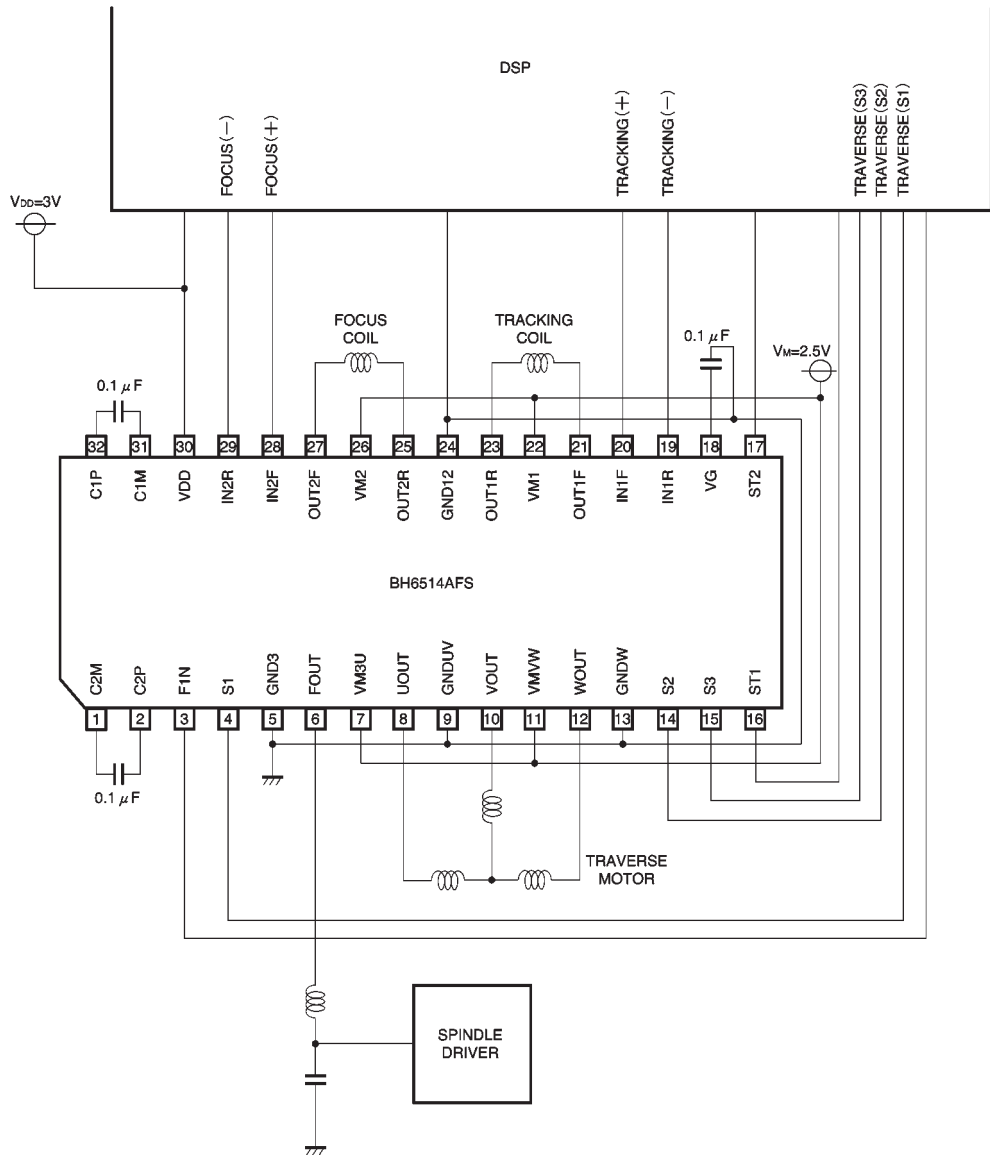

Fig.3

● Operation notes

- (1) The charge pump circuit is a x3 multiplier that uses the voltage on pin 30 as its reference. Therefore, set the voltage (V_{DD}) on pin 30 so that the VG does not exceed its rating.
- (2) If you will use an externally-supplied VG, disconnect the capacitors between pins 31 and 32 and pins 1 and 2.

● External dimensions (Units: mm)

