

IPS511/IPS511S

FULLY PROTECTED HIGH SIDE POWER MOSFET SWITCH

Features

- Over temperature protection (with auto-restart)
- Short-circuit protection (current limit)
- Active clamp
- E.S.D protection
- Status feedback
- Open load detection
- Logic ground isolated from power ground

Product Summary

$R_{ds(on)}$	135m Ω (max)
V_{clamp}	50V
I Limit	5A
$V_{open\ load}$	3V

Description

The IPS511/IPS511S are fully protected five terminal high side switches with built in short circuit, over-temperature, ESD protection, inductive load capability and diagnostic feedback. The output current is controlled when it reaches I_{lim} value. The current limitation is activated until the thermal protection acts. The over-temperature protection turns off the high side switch if the junction temperature exceeds $T_{shutdown}$. It will automatically restart after the junction has cooled $7^{\circ}C$ below $T_{shutdown}$. A diagnostic pin is provided for status feedback of short-circuit, over-temperature and open load detection. The double level shifter circuitry allows large offsets between the logic ground and the load ground.

Truth Table

Op. Conditions	In	Out	Dg
Normal	H	H	H
Normal	L	L	L
Open load	H	H	H
Open load	L	H	H
Over current	H	L (limiting)	L
Over current	L	L	L
Over-temperature	H	L (cycling)	L
Over-temperature	L	L	L

Typical Connection

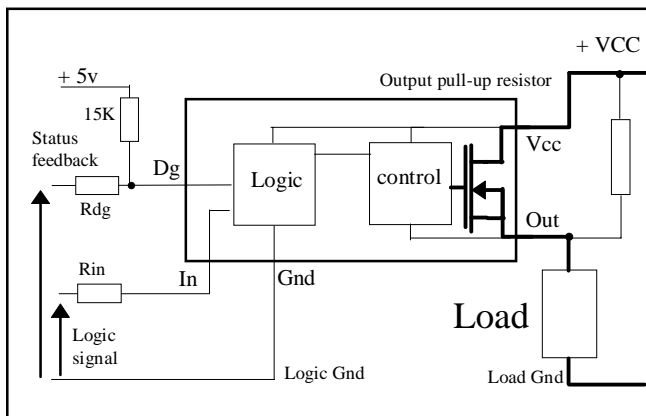

Packages

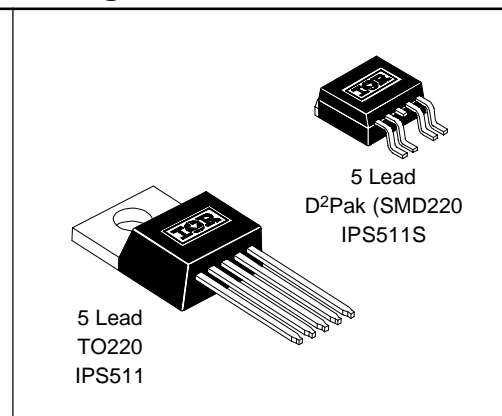

Absolute Maximum Ratings

Absolute maximum ratings indicate sustained limits beyond which damage to the device may occur. All voltage parameters are referenced to GROUND lead. ($T_j = 25^{\circ}\text{C}$ unless otherwise specified).

Symbol	Parameter	Min.	Max.	Units	Test Conditions
V_{out}	Maximum output voltage	$V_{CC}-50$	$V_{CC}+0.3$	V	
V_{offset}	Maximum logic ground to load ground offset	$V_{CC}-50$	$V_{CC}+0.3$		
V_{in}	Maximum Input voltage	-0.3	5.5		
$V_{CC\ max}$	Maximum Vcc voltage	—	50		
$I_{in, max.}$	Maximum IN current	-5	10	mA	
V_{dg}	Maximum diagnostic output voltage	-0.3	5.5	V	
$I_{dg, max}$	Maximum diagnostic output current	-1	10	mA	
$I_{sd\ cont.}$	Diode max. permanent current ⁽¹⁾	—	2.2	A	
$I_{sd\ pulsed}$	Diode max. pulsed current ⁽¹⁾	—	10		
ESD1	Electrostatic discharge voltage (Human Body)	—	4	kV	C=100pF, R=1500Ω,
ESD2	Electrostatic discharge voltage (Machine Model)	—	0.5		C=200pF, R=0Ω, L=10μH
P_d	Maximum power dissipation ⁽¹⁾ ($T_C=25^{\circ}\text{C}$) IPS511 ($r_{th}=80^{\circ}\text{C/W}$) IPS511S	—	25	W	
		—	1.56		
$T_j\ max.$	Max. storage & operating junction temp.	-40	+150	$^{\circ}\text{C}$	
T_{lead}	Lead temperature (soldering 10 seconds)	—	300		

Thermal Characteristics

Symbol	Parameter	Min.	Typ.	Max.	Units	Test Conditions
$R_{th\ 1}$	Thermal resistance junction to case	—	5	—	$^{\circ}\text{C/W}$	TO-220
$R_{th\ 2}$	Thermal resistance junction to ambient	—	60	—		
$R_{th\ 1}$	Thermal resistance with standard footprint	—	60	—		
$R_{th\ 2}$	Thermal resistance with 1" square footprint	—	40	—		D ² PAK (SMD220)
$R_{th\ 3}$	Thermal resistance junction to case	—	5	—		

(1) Limited by junction temperature (pulsed current limited also by internal wiring)

Recommended Operating Conditions

These values are given for a quick design. For operation outside these conditions, please consult the application notes.

Symbol	Parameter	Min.	Max.	Units
V _{CC}	Continuous V _{CC} voltage	5.5	35	V
V _{IH}	High level input voltage	4	5.5	
V _{IL}	Low level input voltage	-0.3	0.9	
I _{out} T _{amb} =85°C	Continuous output current (T _{Ambient} = 85°C, T _J = 125°C, R _{th} < 60°C/W) IPS511 (T _{Ambient} = 85°C, T _J = 125°C, R _{th} = 80°C/W) IPS511	—	1.7 1.5	A
R _{in}	Recommended resistor in series with IN pin	4	6	kΩ
R _{dg}	Recommended resistor in series with DG pin	10	20	

Static Electrical Characteristics

(T_J = 25°C, V_{CC} = 14V unless otherwise specified.)

Symbol	Parameter	Min.	Typ.	Max.	Units	Test Conditions
R _{ds(on)} @T _J =25°C	ON state resistance T _J = 25°C	—	110	135	mΩ	V _{in} = 5V, I _{out} = 2.5A
R _{ds(on)} (V _{CC} =6V)	ON state resistance @ V _{CC} = 6V	—	110	135		V _{in} = 5V, I _{out} = 1A
R _{ds(on)} @T _J =150°C	ON state resistance T _J = 150°C	—	200	—		V _{in} = 5V, I _{out} = 2.5A
V _{CC oper.}	Operating voltage range	5.5	—	35	V	
V _{clamp 1}	V _{CC} to OUT clamp voltage 1	50	56	—		I _d = 10mA (see Fig.1 & 2)
V _{clamp 2}	V _{CC} to OUT clamp voltage 2	—	58	65		I _d = I _{sd} (see Fig.1 & 2)
V _f	Body diode forward voltage	—	0.9	1.2		I _d = 2.5A, V _{in} = 0V
I _{CC off}	Supply current when OFF	—	16	50	μA	V _{in} = 0V, V _{out} = 0V
I _{CC on}	Supply current when ON	—	0.7	2	mA	V _{in} = 5V
I _{CC ac}	Ripple current when ON (AC RMS)	—	20	—	μA	V _{in} = 5V
V _{dgl}	Low level diagnostic output voltage	—	0.15	0.4	V	I _{dg} = 1.6 mA
I _{oh}	Output leakage current	—	60	110	μA	V _{out} = 6V
I _{ol}	Output leakage current	0	—	25		V _{out} = 0V
I _{dg leakage}	Diagnostic output leakage current	—	—	10		V _{dg} = 5.5V
V _{ih}	IN high threshold voltage	—	2.3	3	V	
V _{il}	IN low threshold voltage	1	1.95	—		
I _{in, on}	On state IN positive current	—	70	200	μA	V _{in} = 5V
I _{n hyst.}	Input hysteresis	0.1	0.25	0.5	V	

Switching Electrical Characteristics

$V_{CC} = 14V$, Resistive Load = 5.6Ω , $T_j = 25^\circ C$, (unless otherwise specified).

Symbol	Parameter	Min.	Typ.	Max.	Units	Test Conditions
T_{don}	Turn-on delay time	—	7	50	μs	See figure 3
T_{r1}	Rise time to $V_{out} = V_{CC} - 5V$	—	10	50		
T_{r2}	Rise time $V_{CC} - 5V$ to $V_{out} = 90\%$ of V_{CC}	—	45	100		
dV/dt (on)	Turn ON dV/dt	—	1.3	4	$V/\mu s$	
E_{on}	Turn ON energy	—	400	—	μJ	
T_{doff}	Turn-off delay time	—	15	50	μs	See figure 4
T_f	Fall time to $V_{out} = 10\%$ of V_{CC}	—	10	50		
dV/dt (off)	Turn OFF dV/dt	—	2	6		
E_{off}	Turn OFF energy	—	80	—	μJ	
T_{diag}	V_{out} to V_{diag} propagation delay	—	5	15	μs	See figure 6

Protection Characteristics

Symbol	Parameter	Min.	Typ.	Max.	Units	Test Conditions
I_{lim}	Internal current limit	3	5	7	A	$V_{out} = 0V$
T_{sd+}	Over-temp. positive going threshold	—	165	—	$^\circ C$	See fig. 2
T_{sd-}	Over-temp. negative going threshold	—	158	—	$^\circ C$	See fig. 2
V_{sc}	Short-circuit detection voltage (3)	2	3	4	V	See fig. 2
$V_{open load}$	Open load detection threshold	2	3	4	V	

(3) Referenced to V_{CC}

Lead Assignments

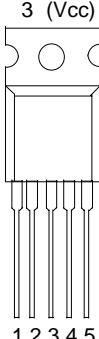
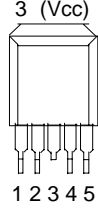
 <p>3 (Vcc)</p> <p>1 2 3 4 5</p> <p>5 Lead - TO220</p>	<p>1 - Ground 2 - In 3 - Vcc 4 - DG 5 - Out</p>	 <p>3 (Vcc)</p> <p>1 2 3 4 5</p> <p>5 Lead - D²PAK (SMD220)</p>
IPS511		IPS511S
Part Number		

Functional Block Diagram

All values are typical

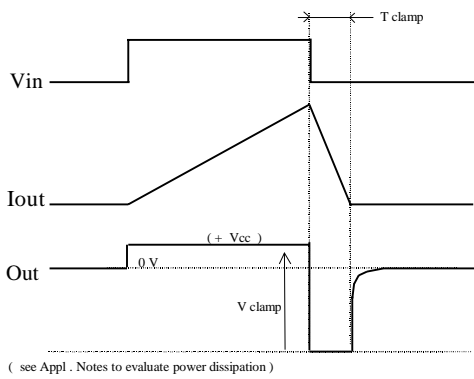
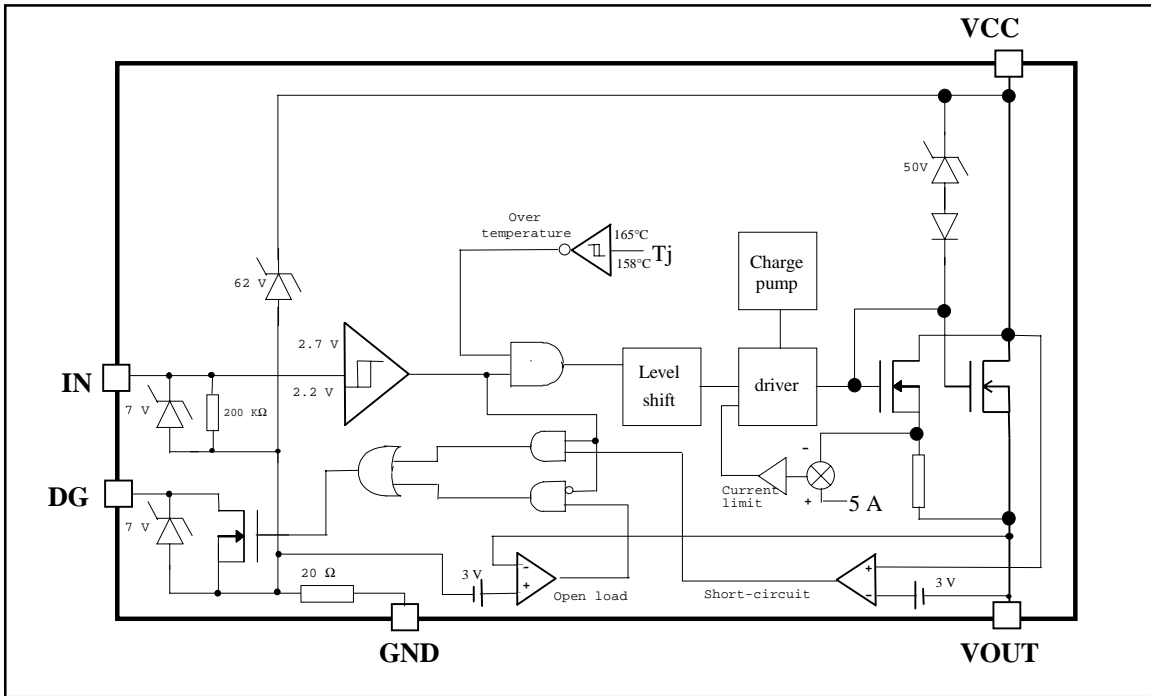

Figure 1 - Active clamp waveforms

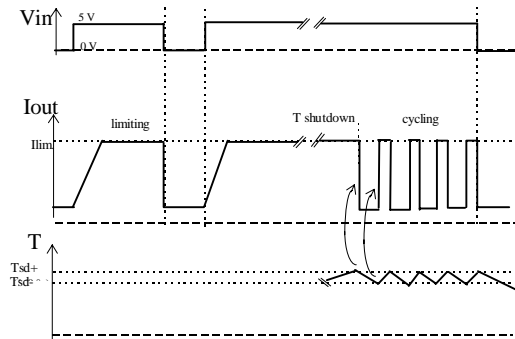

Figure 2 - Protection timing diagram

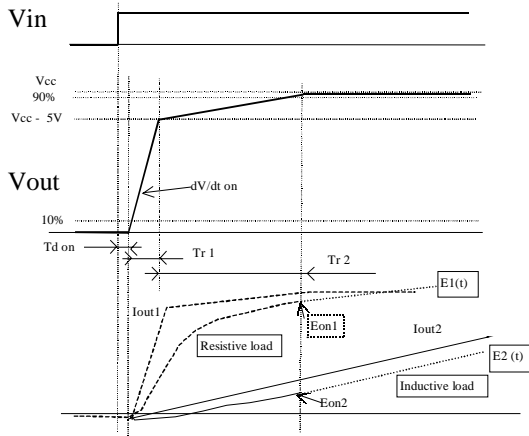

Figure 3 - Switching times definition (turn-on)
Turn on energy with a resistive or an inductive load

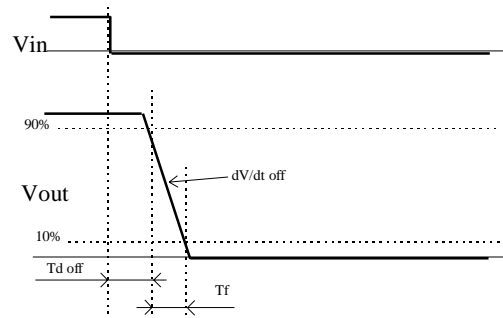

Figure 4 - Switching times definition (turn-off)

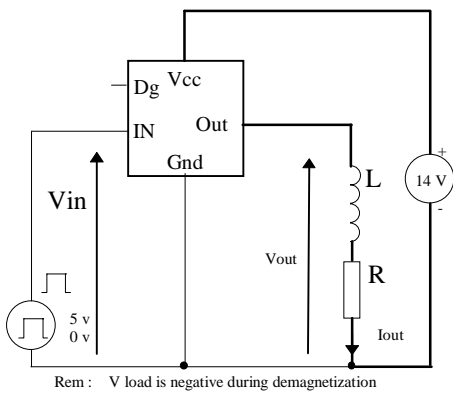

Figure 5 - Active clamp test circuit

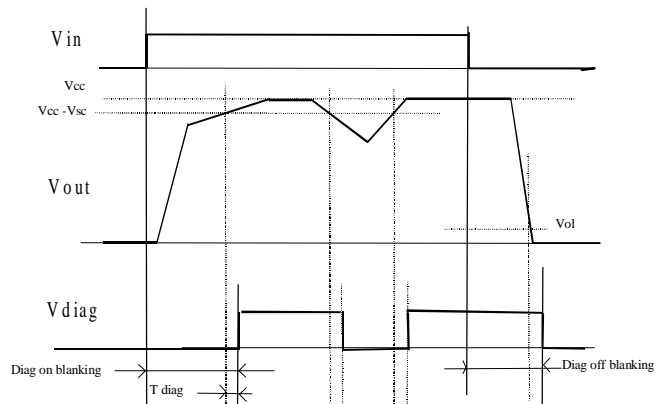

Figure 6 - Diagnostic delay definitions

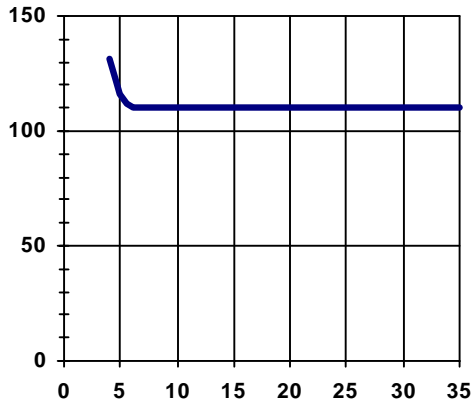

Figure 7 - R_{ds(on)} (mΩ) Vs V_{CC} (V)

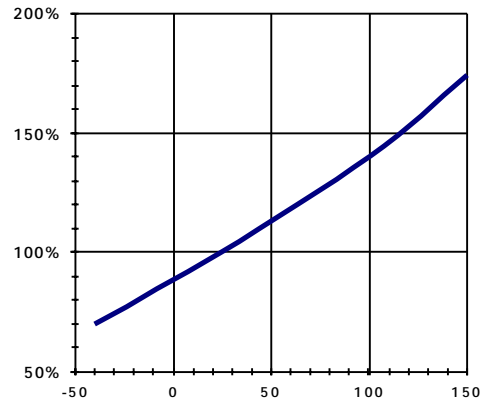

Figure 8 - Normalized R_{ds(on)} (%) Vs T_j (°C)

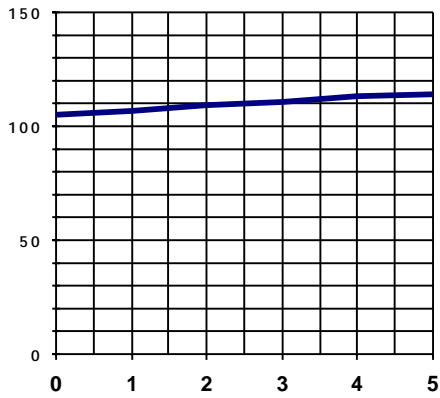

Figure 9 - R_{ds(on)} (mΩ) Vs I_{out} (A)

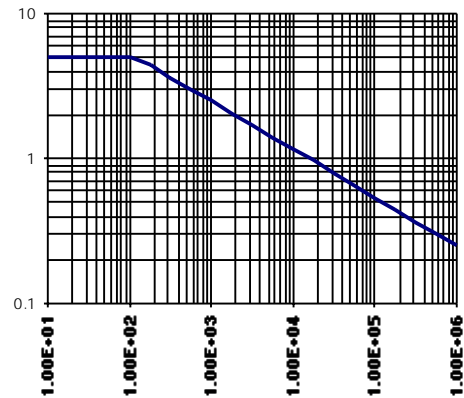

Figure 10 - Max. I_{out} (A) Vs Load Inductance (μH)

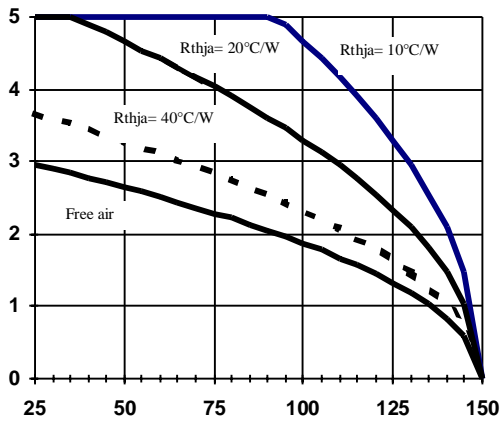

Figure 11a - Max load current (A) Vs Tamb (°C)
IPS511

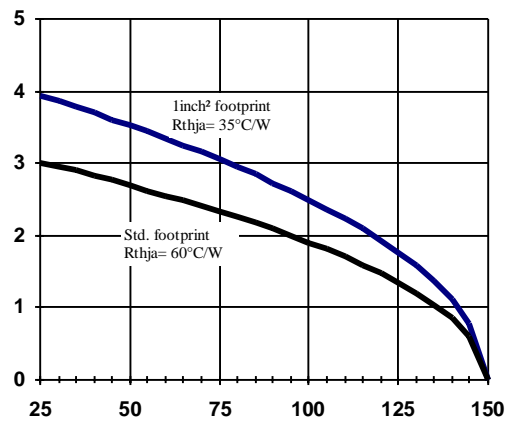

Figure 11b - Max load current (A) Vs Tamb (°C)
IPS511S

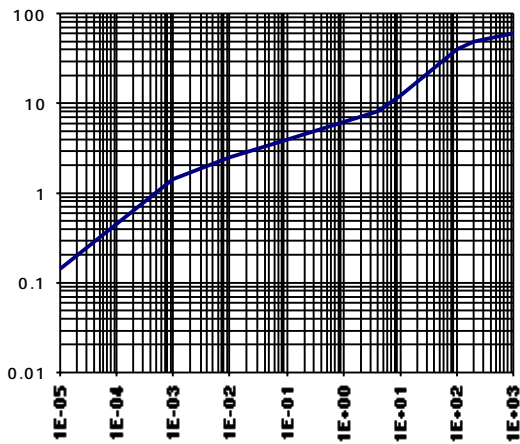

Figure 12 - Transient Thermal Impedance (°C/W)
Vs Time (S)

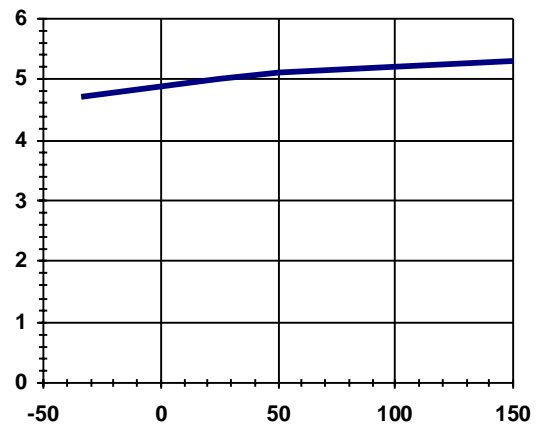

Figure 13 - Ilim (A) Vs Tj (°C)

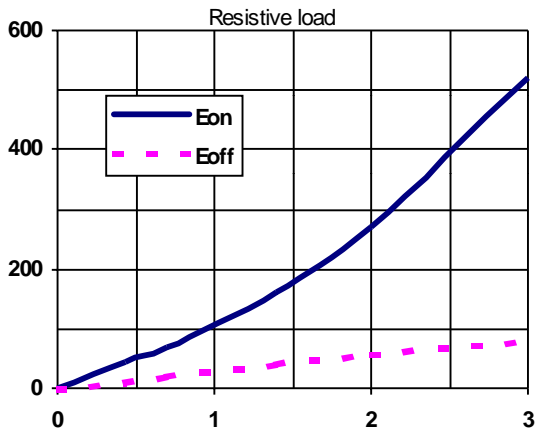

Figure 14 - E_{on}, E_{off} (μJ) (A) Vs I_{out} (A)

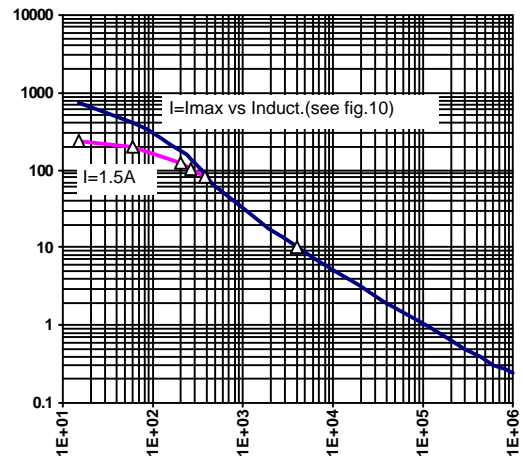

Figure 15 - E_{on} (μJ) Vs Load Inductance (μH)
(see Fig. 3)

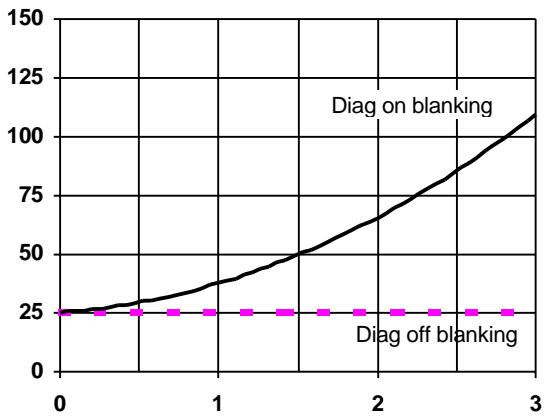

Figure 16 - Diag Blanking time (μs) Vs I_{out} (A)
(resistive load - see Fig. 6)

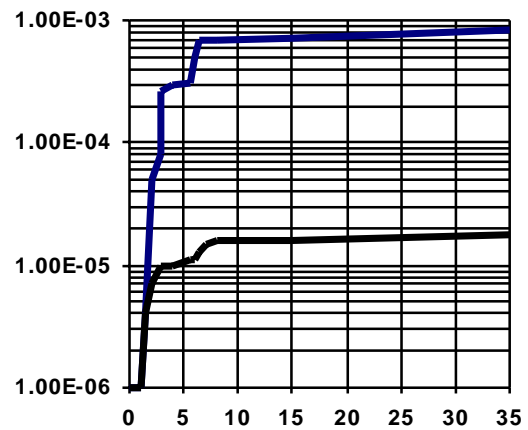

Figure 17 - I_{CC} (mA) Vs V_{CC} (V)

IPS511/IPS511S

International
IR Rectifier

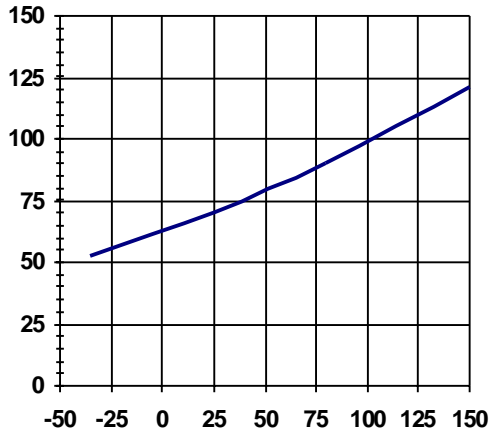
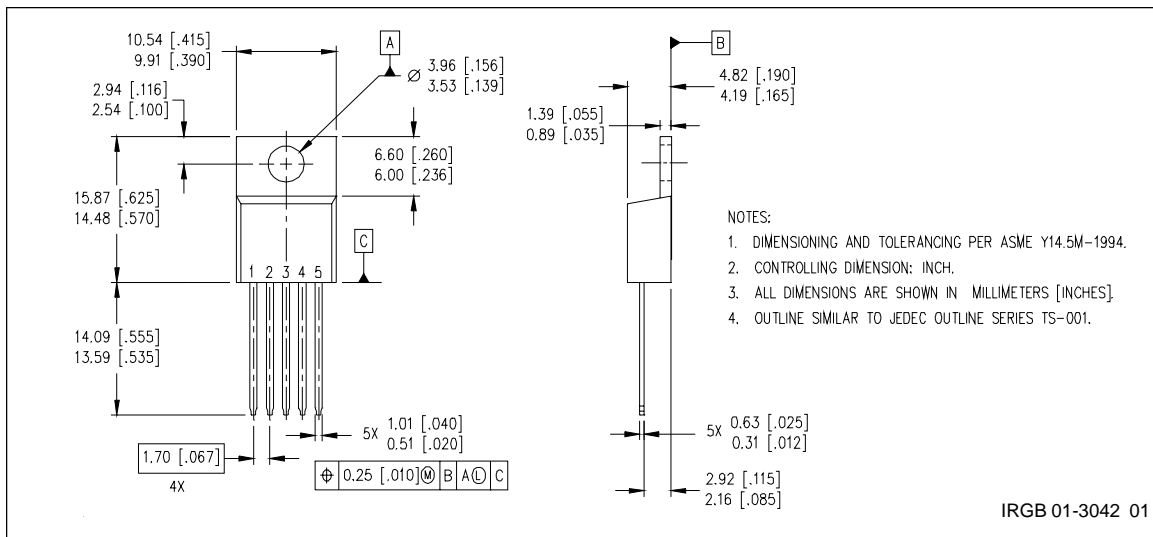
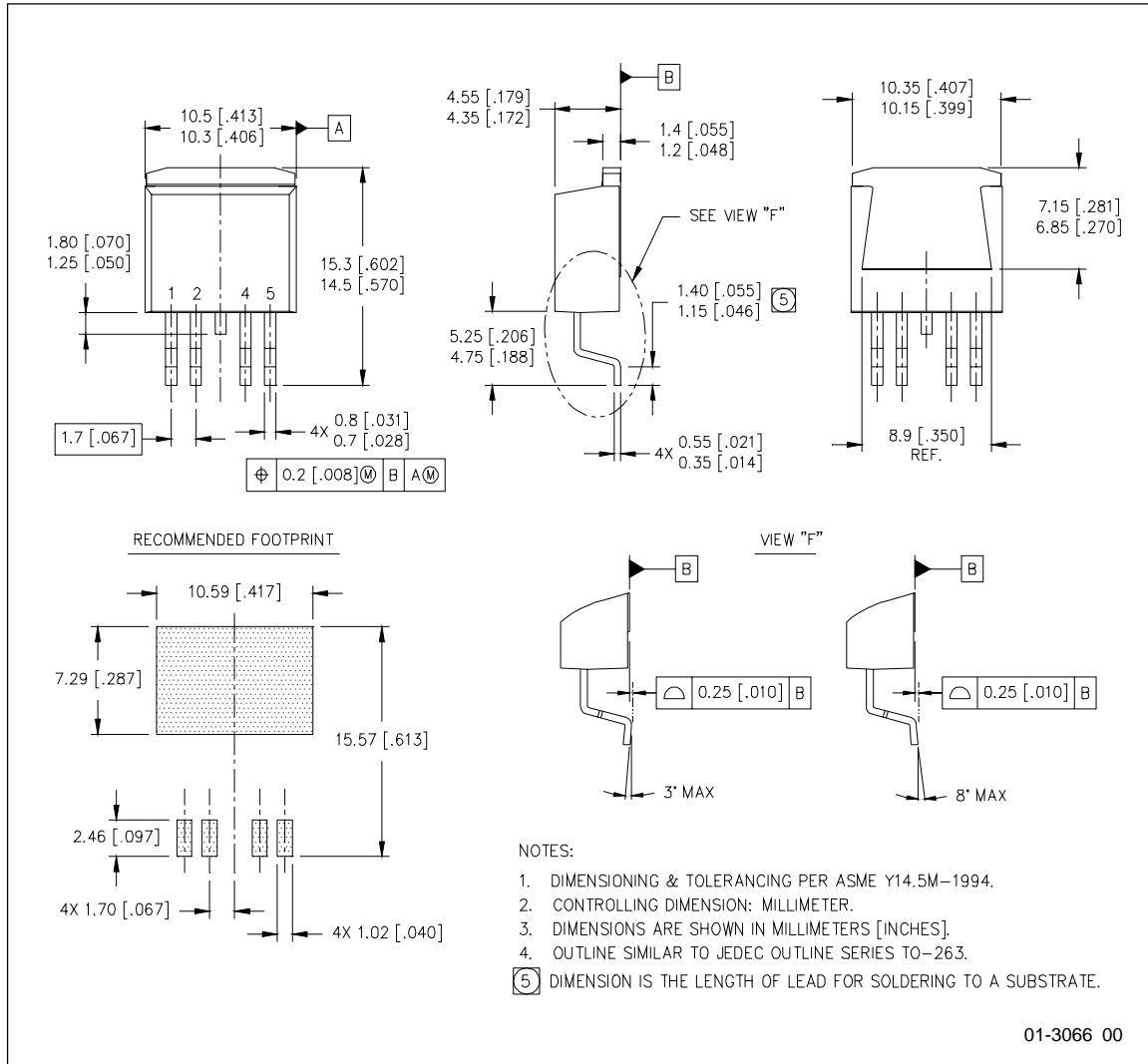

Figure 18 - I_{in} @ V_{in} = 5V (μA) Vs T_j (°C)

Case Outline 5 Lead - TO220



Case Outline 5 Lead - D²PAK (SMD220)



Tape & Reel 5 Lead - D²PAK (SMD220)

