

MAXIM

AC To DC Regulator (110/220VAC To 5.0VDC)

MAX600/01/02

General Description

The MAX600 family of AC to DC Power Converters minimizes the cost, simplifies the design, and reduces the component count, size, and weight of ½ watt power supplies. With an 8 VRMS input voltage the MAX600 needs only a single filter capacitor to make a complete 5V, 100mA power supply. With the addition of a current limiting resistor and a current limiting capacitor, the MAX600 connects directly to the 100 VAC or 220 VAC power line to make a minimum component count 110/220VAC to 5VDC power supply.

The three members of the MAX600 family differ in three respects: full or half wave rectification, 12V or 18V zener voltage, and the assignment of pin 4 to the function of setting the output voltage or setting the time delay. The MAX600 has a full wave rectifier, a 12V zener, and the output voltage is either the internally preset +5V or user adjustable from 1.3 to 9V. The MAX601 has a half wave rectifier, a 12V zener, a fixed 5V output, and pin 4 controls the time delay of the reset output. The MAX602 has a full wave rectifier, an 18V zener, and the output voltage is either the internally preset +5V or user adjustable in the range of +1.3V to +15V.

For more detailed application information on AC to DC Regulators, refer to the MAX610/11/12 data sheet.

Applications

Minimum Component Count Power Supplies
Uninterruptable 5V Power Supplies
Precision Battery Chargers
Line Powered Appliances
Industrial Controls
Off Line Instruments
Triac Output Power Controllers

Typical Operating Circuit

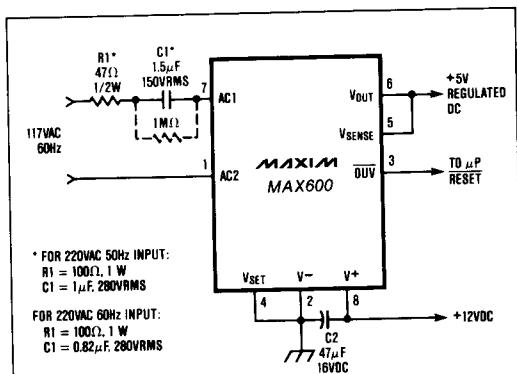

Figure 1. Simple Line-Powered 5V Supply.

Features

- ◆ Direct 110/220VAC to 5VDC Conversion
- ◆ Minimum External Component Count
- ◆ Output Voltage Preset to 5V ±4%
- ◆ 70μA Typical Quiescent Current
- ◆ Over/Undervoltage Detection
- ◆ Power-up Reset Circuit with Programmable Delay
- ◆ Programmable Current Limiting
- ◆ Programmable Output Voltage: 1.3V to 15V
- ◆ Low Cost, Limited Temperature Range Alternative to MAX610/11/12

Ordering Information

PART	TEMP. RANGE	PACKAGE
MAX600LPA2	0°C to +50°C	8 Lead Plastic Dip
MAX601LPA2	0°C to +50°C	8 Lead Plastic DIP
MAX602LPA2	0°C to +50°C	8 Lead Plastic Dip

Pin Configurations

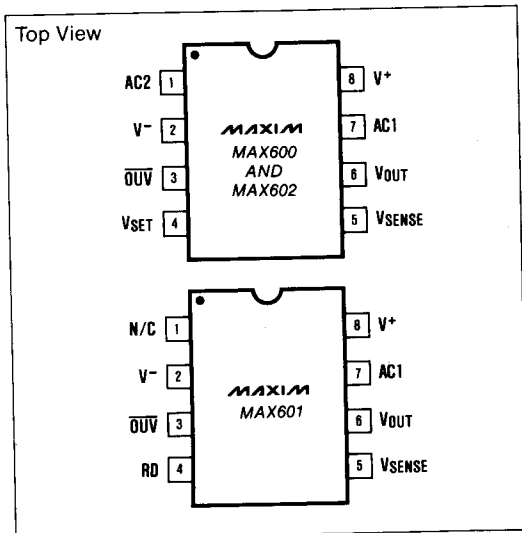

AC To DC Regulator (110/220VAC To 5.0VDC)

ABSOLUTE MAXIMUM RATINGS

Operating Temperature Range	0°C to +50°C
Maximum Junction Temperature	+125°C
Storage Temperature Range	-65°C to +150°C
Lead Temperature (Soldering, 10 seconds)	+300°C
Power Dissipation @ 25°C	750mW
derate 8mW/C above 25°C.	
Input Current	
MAX601	
AC1, V ⁺ ; 250μs non-repetitive pulse	5A
AC1, V ⁺ ; continuous	180mA RMS
V ⁺	150mA
MAX600, MAX602	
AC1, AC2; 250μs non-repetitive pulse	5A
AC1, AC2; continuous	120mA RMS
V ⁺	150mA
All other terminals	10mA

Input Voltage	
MAX600, MAX601 (Note 1)	
AC1, AC2	11.5V
V ⁺	10.8V
MAX602	
AC1, AC2	17V
V ⁺	16.2V
All other terminals	(V ⁻ - 0.3V) to (V ⁺ + 0.3V)
Output Current	
V ⁺ , V _{OUT}	150mA
OUV	10mA

Note 1: The maximum input voltage may be exceeded if the maximum input current and power dissipation specifications are observed.

Stresses above those listed under "Absolute Maximum Ratings" may cause permanent damage to the device. These are stress ratings only, and functional operation of the device at these or any other conditions above those indicated in the operational sections of the specifications is not implied. Exposure to absolute maximum ratings conditions for extended periods may affect device reliability.

ELECTRICAL CHARACTERISTICS

(T_A = 25°C, V⁺ = 10V, R_{SENSE} = 0Ω, V_{SET} connected to V⁻ unless noted)

PARAMETER	SYMBOL	CONDITIONS	MIN	TYP	MAX	UNITS
Diode Forward Voltage	V _F	I _F = 1mA I _F = 50mA		0.62 1.1	2.0	V
Zener Voltage	V _Z	I _Z = 50mA, Measure at V ⁺ MAX600, MAX601, MAX602		12.4 18.6		V
Zener Dynamic Resistance	R _Z	I _Z = 50mA MAX600, MAX601, MAX602		6 9		Ω
Preset Output Voltage	V _{OUT}	0.5mA ≤ I _{OUT} ≤ 50mA T _A = 25°C 0°C ≤ T _A ≤ +50°C	4.80 4.75	5.00 5.00	5.20 5.25	V
Temperature Coefficient of Output Voltage	$\frac{\Delta V_{OUT}}{\Delta T}$	0°C ≤ T _A ≤ +50°C		±100		ppm/°C
Internal Voltage Reference	V _{SET}	MAX600, MAX602		1.3		V
Line Regulation (DC Input)	$\frac{\Delta V_{OUT}}{\Delta V^+}$	8V ≤ V ⁺ ≤ V _Z		0.25		%/V
Line Regulation (AC Input)	$\frac{\Delta V_{OUT}}{\Delta V_{AC}}$	I _{OUT} = 10mA 70V _{RMS} < V _{IN} < 140V _{RMS} or 140V _{RMS} < V _{IN} < 280V _{RMS}		0.001 0.001		%/V
Output Impedance	$\frac{\Delta V_{OUT}}{\Delta I_{OUT}}$	I _{OUT} Changing from 1mA to 51mA		0.6	2.0	Ω
Input-Output Voltage Differential	V ⁺ - V _{OUT}	I _{OUT} = 25mA		1.1	2.0	V
V _{SET} Input Current	I _{SET}			0.01	100	nA
Supply Current Total	I [*]			70	150	μA
Overvoltage Detection Voltage	V _{OUVH}	Measured at V _{SENSE}		5.4	5.65	V
Undervoltage Detection Voltage	V _{OUVL}	Measured at V _{SENSE}	4.35	4.65		V
OUV Output Leakage	I _{OUV}	V _{SENSE} = 5V, OUV = 5V		0.001	10	μA
OUV Output Voltage	V _{OUV}	V _{SENSE} ≥ 5.65V or V _{SENSE} ≤ 4.35V, I _{OUV} = 1mA			0.4	V
Reset Time Delay	t _{DELAY}	MAX601, C3 = 0.01μF		30		ms
Reset Pin Threshold	V _{TH}	MAX601, V ⁺ = V _Z		8.0		V

AC To DC Regulator (110/220VAC To 5.0VDC)

MAX600/01/02

Pin Descriptions

PIN	PIN #	DESCRIPTION
AC1	7	AC input to the internal diode rectifier.
AC2	1 (MAX600/02)	Second AC input to the full wave bridge rectifier.
N/C	1 (MAX601)	This pin is not connected on the MAX601.
V ⁻	2	Negative output terminal. This terminal is also an AC input for the half wave rectifier of MAX601.
V _{OUT}	6	Positive regulated DC output.
V _{SENSE}	5	Current limit input. The output short circuit current limit is 0.6V/R _{SENSE} , where R _{SENSE} is a current sensing resistor connected between V _{OUT} and V _{SENSE} .
OVV	3	This open drain pin goes low during undervoltage and overvoltage conditions. The undervoltage and overvoltage thresholds are fixed at 4.65V (undervoltage) and 5.4V (overvoltage) and do not change, even if the output voltage is changed via the V _{SET} terminal.

PIN	PIN #	DESCRIPTION
V ⁺	8	Positive unregulated or raw DC output of the rectifier. The raw DC filter capacitor connects to this terminal.
RD	4 (MAX601)	An external capacitor connected to the Reset Delay pin determines the Reset Delay period. The reset time delay is directly proportional to the capacitance connected to this pin; each 0.01μF of capacitance results in 30 milliseconds of delay. This delay period must elapse before the Reset/OVV pin goes high after an overvoltage or undervoltage condition.
V _{SET}	4 (MAX600/02)	If the V _{SET} terminal is grounded, the MAX600 and MAX602 output voltage will be the preset 5V ±4%. Alternatively, the V _{SET} input can be used to set the output voltage to any voltage from 1.3V to 15V (MAX602) or 1.3V to 10V (MAX600 and MAX601), using a simple resistive voltage divider.

Block Diagrams

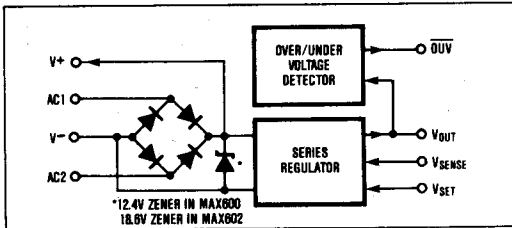

Block Diagram MAX600 and MAX602

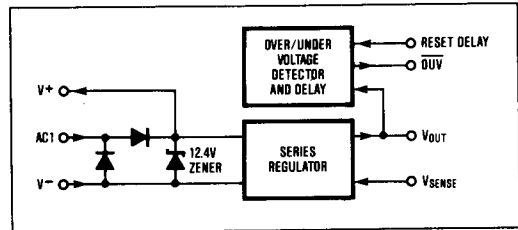

Block Diagram MAX601

Typical Applications

6

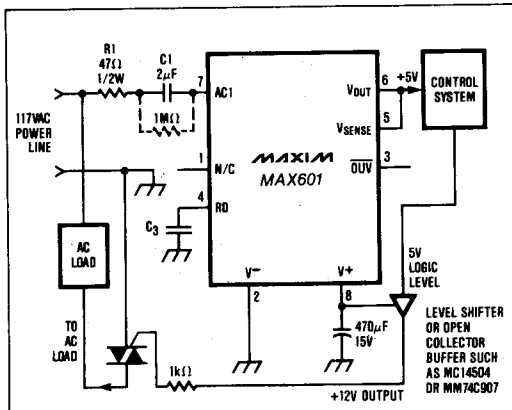

Figure 2. Driving Triacs With +12V Supply.

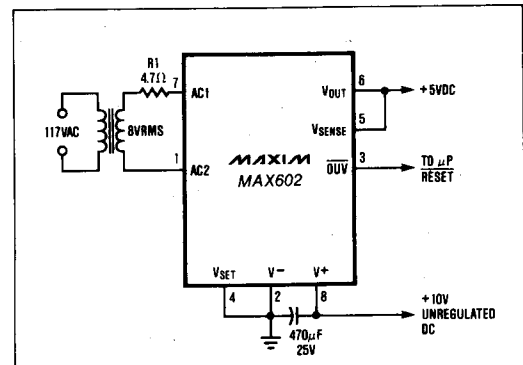

Figure 3. Transformer Isolated 5V Power Supply.

AC To DC Regulator (110/220VAC To 5.0VDC)

Cautions and Component Selection

1) Unless driven by a transformer, the 5V output of the MAX600/01/02 is **NOT ISOLATED** from the power line and all circuitry connected to the MAX600/01/02 should be treated as if it were directly connected to the power line. The MAX600/01/02, its circuitry, and all components driven by the 5V output present a shock hazard and should be in a protective enclosure to prevent accidental contact.

2) Use an isolation transformer or ground fault interrupter (GFI) when breadboarding, testing, or troubleshooting a MAX600 family based line-power supply or any circuitry powered by the MAX600 family. If the MAX600/01/02 is connected directly to the power line, do **NOT** connect the ground of an oscilloscope to the circuit — this will severely damage the oscilloscope and destroy the MAX600/01/02.

Table 1. DESIGN FORMULAE

FORMULA	EXAMPLE in FIGURE	COMMENTS
$V_{OUT} = 5V \pm 4\%$, V_{SET} Grounded	1	
$V_{OUT} = 1.3V \left(1 + \frac{R_2}{R_3}\right)$	4	MAX600 and MAX602
$I_{OUT(MAX)} = C1 \times 4 \sqrt{2} \times V_{RMS} \times F_{IN}$	1	Full wave — MAX600, MAX602
$I_{OUT(MAX)} = C1 \times 2 \sqrt{2} \times V_{RMS} \times F_{IN}$	2	Half wave — MAX601
$I_{CURRENT LIMIT} = \frac{0.6V}{R_{SENSE}}$	4	
$C1 = \frac{I_{OUT(MAX)}}{(V_{RMS} - V_{OUT}) \times 4 \sqrt{2} \times F_{IN}}$	1	Full wave — MAX600, MAX602
$C1 = \frac{I_{OUT(MAX)}}{(V_{RMS} - V_{OUT}) \times 2 \sqrt{2} \times F_{IN}}$	2	Half wave — MAX601
Time delay = $C3 \times 3$ (in secs) (in μF)	2	MAX601 only

Current Limiting Capacitor, C1

This capacitor is the most critical component for a 110/220VAC input power supply based on the MAX601 family. It must continuously withstand the full line voltage so it should be rated for AC operation. A conservative designer will use a capacitor rated for at least 150VRMS working voltage for 110VAC circuits, and at least 280VRMS for 220VAC or 240VAC circuits. This capacitor must be a NON-POLARIZED capacitor such as polyester (Mylar™) or polypropylene metallized film. Metallized film capacitors are preferred over metal foil capacitors since metal foil capacitors are more likely to fail as a short circuit than are metallized film capacitors.

The value of C1 determines both the power dissipation of the MAX600/01/02 and the maximum available output current. The value of C1 should be the smallest value that will deliver the desired output current

Maxim cannot assume responsibility for use of any circuitry other than circuitry entirely embodied in a Maxim product. No circuit patent licenses are implied. Maxim reserves the right to change the circuitry and specifications without notice at any time.

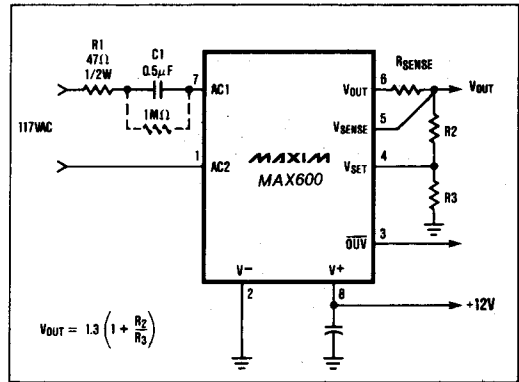

Figure 4. Adjustable Output Voltage.

at minimum line voltage, since the power dissipated by the MAX600/01/02 increases with increasing values of C1. Table 1 gives the formula for calculating C1 as a function of the desired output current.

Current Limiting Resistor, R1

R1 limits the maximum peak current that occurs when power is first applied to the MAX600 just as the power line voltage is at its maximum. The instantaneous peak current must be limited to 5 Amps. For 110VAC input voltage R1 must be 33Ω or greater; for 220VAC input voltage R1 must be 68Ω or greater. The recommended values are 47Ω for 110VAC and 100Ω for 220VAC. The power dissipation in R1 is constant, independent of the load current.

With 110VAC 60Hz input

$$Pd(R1) = 1.6 \times C1^2 \times R1 \quad (\text{in mW}) \quad (\text{in } \mu F) \quad (\text{in } \Omega)$$

With 220VAC 50Hz input

$$Pd(R1) = 2.7 \times C1^2 \times R1 \quad (\text{in mW}) \quad (\text{in } \mu F) \quad (\text{in } \Omega)$$

Raw DC Filter Capacitor, C2

This capacitor is normally an aluminum or tantalum electrolytic capacitor. C2 is ordinarily 47μF when the MAX600/02 are driven from the 110/220VAC power line. The half wave MAX601 requires larger values for C2 since the output current is supplied by C2 for one-half of each line cycle.

Adjustable Output Voltage

The MAX601 output voltage is fixed at 5V ± 4%. The MAX600 and MAX602 output voltages can be set to 5V ± 4% by simply connecting the VSET terminal to V-; other output voltages can be selected by connecting an external resistive voltage divider between the output and VSET as shown in Figure 4. Calculate the resistor values for other voltages using the formula in Table 1.