

## GN8062

## GaAs IC

For semiconductor laser drive

## ■ Features

- High-speed switching
- High output
- Pulse current and DC bias current can be controlled.

## ■ Absolute Maximum Ratings (Ta = 25°C)

Parameter	Symbol	Rating	Unit
Power supply voltage	V <sub>DD</sub>	6	V
	V <sub>SS</sub>	-6	V
Pin voltage	V <sub>IN</sub>	-0.5 to V <sub>DD</sub> -1.5	V
	V <sub>IP</sub> <sup>*5</sup>	1.5 to V <sub>DD</sub>	V
	V <sub>OUT</sub> <sup>*1</sup>	V <sub>DD</sub>	V
Power current	I <sub>DD</sub> <sup>*4</sup>	50	mA
	I <sub>SS</sub>	40	mA
Output current	I <sub>OUT</sub>	145	mA
Allowable power dissipation	P <sub>D</sub> <sup>*2</sup>	700	mW
Channel temperature	T <sub>ch</sub>	150	°C
Storage temperature	T <sub>stg</sub>	-55 to +150	°C
Operating ambient temperature	T <sub>opr</sub> <sup>*3</sup>	-10 to +75	°C

\* 1 Do not apply the voltage higher than the set V<sub>DD</sub>.

\* 2 Guaranteed value of the unit at Ta= 25°C.

\* 3 Range in which the IC circuit function operates and not the guaranteed range of electric characteristics.

\* 4 I<sub>DD</sub> is a current when the pulse output current is zero.

\* 5 Voltage when the constant current source has been connected.

## ■ Electrical Characteristics (Ta = 25°C)

Parameter	Symbol	Test circuit	Condition	Min	Typ	Max	Unit
Pulse output current	I <sub>pmax.</sub>	1	V <sub>DD</sub> = 5V, V <sub>SS</sub> = -5V, V <sub>IN</sub> = 2V, I <sub>p</sub> =120mA, R <sub>L</sub> =10Ω	100	120		mA
	I <sub>pmin.</sub>	1	V <sub>DD</sub> = 5V, V <sub>SS</sub> = -5V, V <sub>IN</sub> = 0.4V, I <sub>p</sub> =120mA, R <sub>L</sub> =10Ω		1	5	mA
Supply current	I <sub>DD</sub> <sup>*1</sup>	2	V <sub>DD</sub> = 5V, V <sub>SS</sub> = -5V, V <sub>IN</sub> = 0.4V		35	50	mA
	I <sub>SS</sub>	2	I <sub>p</sub> = 0, R <sub>L</sub> =10Ω		25	40	mA
Input voltage	V <sub>IH</sub>			2.5			V
	V <sub>IL</sub>					0.4	V
Rise time	t <sub>r</sub> <sup>*2</sup>	3	V <sub>DD</sub> = 5V, V <sub>SS</sub> = -5V, I <sub>p</sub> =100mA			7	ns
Fall time	t <sub>f</sub> <sup>*2</sup>	3	R <sub>L</sub> =10Ω			5	ns

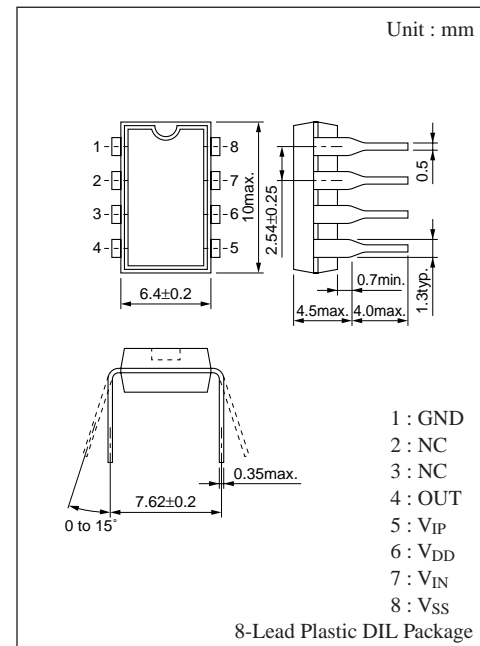

- \* 1 The current value to be supplied from the 5V power supply is a total sum of this value plus the pulse output current and bias output current.
- \* 2 Waveform of input and output signals

Input signal

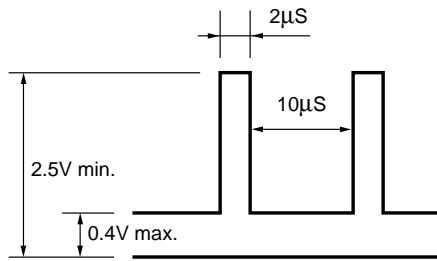

\* The rise/fall time of the input signal is 2ns (10 to 90%)

Output waveform

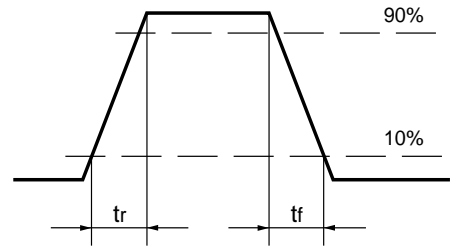

$t_r \dots 10\% \text{ to } 90\%$   
 $t_f \dots 90\% \text{ to } 10\%$

Test circuit 1

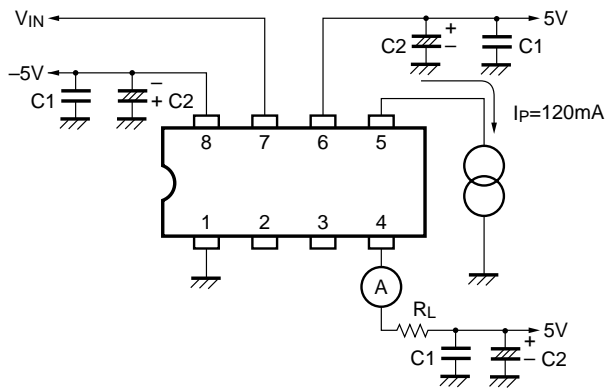

Test circuit 2

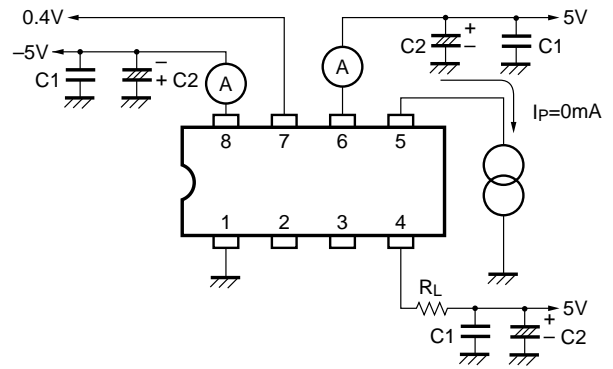

Test circuit 3

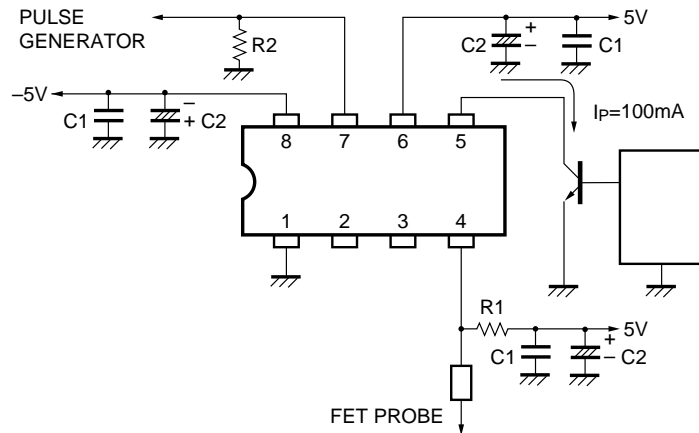

$C_1 : 0.1\mu\text{F}$   
 $C_2 : 3.3\mu\text{F}$   
 $R_1 : 10\Omega$   
 $R_2 : 50\Omega$

## ■ Block Diagram

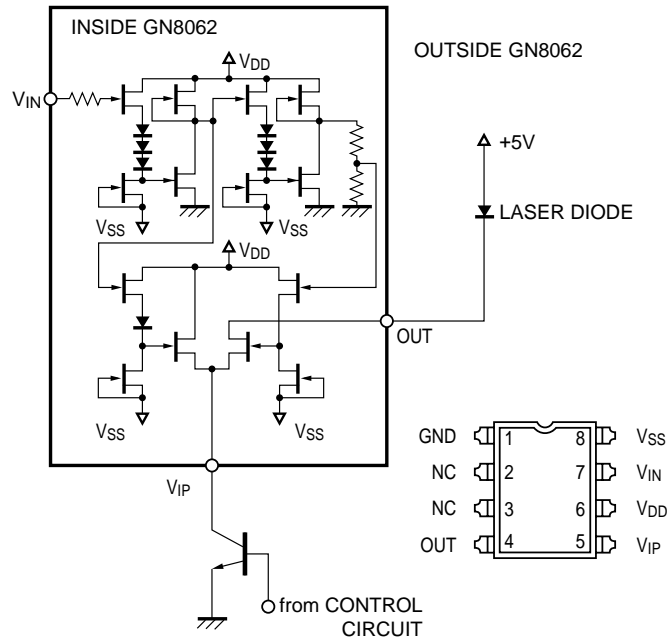

## ■ Caution for Handling

- 1) The recommended  $V_{IN}$  voltage is 2.5 to 3V for [H] and 0 to 0.4V for [L].
- 2) Do not apply  $V_{IN}$  while the power supply is OFF.
- 3) For the current source to be connected to the  $V_{IP}$  pin, use a Si bipolar transistor as shown in the circuit diagram.

(Example: 2SD874)

To connect a resistor to the emitter or collector, use a resistor of a few ohm. The use of higher resistor may cause large change in the voltage at the  $V_{IP}$  pin, and may make the output waveform distortion. (See the pulse output current control example).

To use another current control circuit, set so that the  $V_{IP}$  pin voltage becomes around 2V.

- 4) When mounting, minimize the connection distance between the semiconductor laser and IC, and use the chip parts (C, R) of less parasitic effects.
- 5) Attention to damage by the power surge (see the example connection of the pin protection circuit).  
During handling, take care to ground the human body and solder iron tip.
- 6) When the power supply is turned ON and OFF, set the current value of the current source connected to the  $V_{IP}$  pin to zero. This is important to prevent the large current flow through the semiconductor laser during power ON/OFF.  
When the power supply is ON, be sure to turn ON  $V_{DD}$ , after  $V_{SS}$  is completely equal to  $-5V$ . When the power supply is OFF, be sure to turn OFF  $V_{SS}$ , after  $V_{DD}$  is completely 0V.

- 7) Pay attention to release the heat.

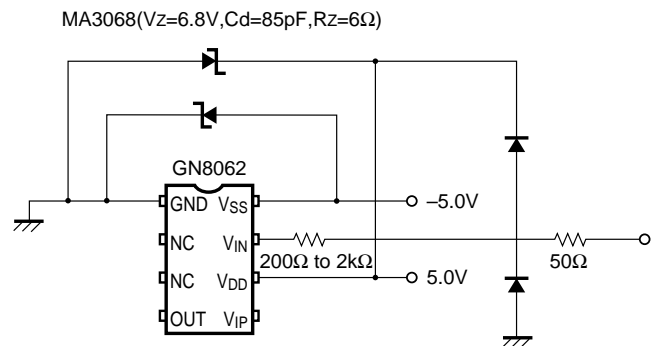

Connection example of pin protection circuit

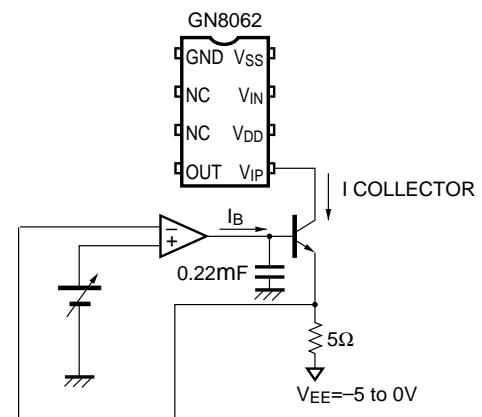

Example of pulse output current control circuit