

# ASYNCHRONOUS SRAM

# 128K x 8 SRAM

**WITH SINGLE CHIP ENABLE  
 REVOLUTIONARY PINOUT**

**FEATURES**

- Fast access times: 10, 12, 15 and 20ns
- Fast OE# access times: 5, 6, 7 and 8ns
- Single +5V  $\pm 10\%$  power supply
- Fully static -- no clock or timing strobes necessary
- All inputs and outputs are TTL-compatible
- Three state outputs
- Center power and ground pins for greater noise immunity
- JEDEC standard for functionality and revolutionary pinout
- Easy memory expansion with CE# and OE# options
- Automatic CE# power down
- High-performance, low-power consumption, CMOS double-poly, double-metal process

**OPTIONS**

- Timing
  - 10ns access
  - 12ns access
  - 15ns access
  - 20ns access
- Packages
  - 32-pin SOJ (400 mil)
  - 32-pin SOJ (300 mil)
- Power consumption
  - Standard
  - Low
- Temperature
  - Commercial
  - Industrial

**MARKING**

-10	
-12	
-15	
-20	
J	
SJ	
None	
L	
None	(0°C to 70°C)
I	(-40°C to 85°C)

**GENERAL DESCRIPTION**

The GVT72128A8 is organized as a 131,072 x 8 SRAM using a four-transistor memory cell with a high performance, silicon gate, low-power CMOS process. Galvantech SRAMs are fabricated using double-layer polysilicon, double-layer metal technology.

This device offers center power and ground pins for improved performance and noise immunity. Static design eliminates the need for external clocks or timing strobes. For increased system flexibility and eliminating bus contention problems, this device offers chip enable (CE#) and output enable (OE#) with this organization.

Writing to these devices is accomplished when write enable (WE#) and chip enable (CE#) inputs are both LOW. Reading is accomplished when (CE#) and (OE#) go LOW with (WE#) remaining HIGH. The device offers a low power standby mode when chip is not selected. This allows system designers to meet low standby power requirements.

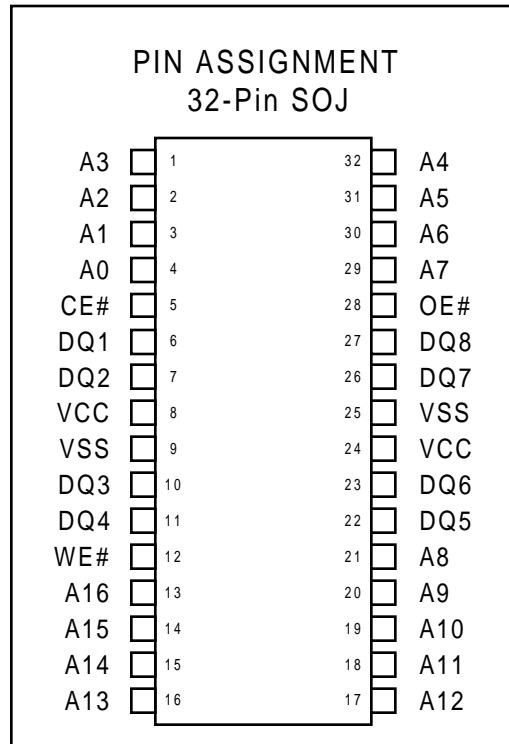

## FUNCTIONAL BLOCK DIAGRAM

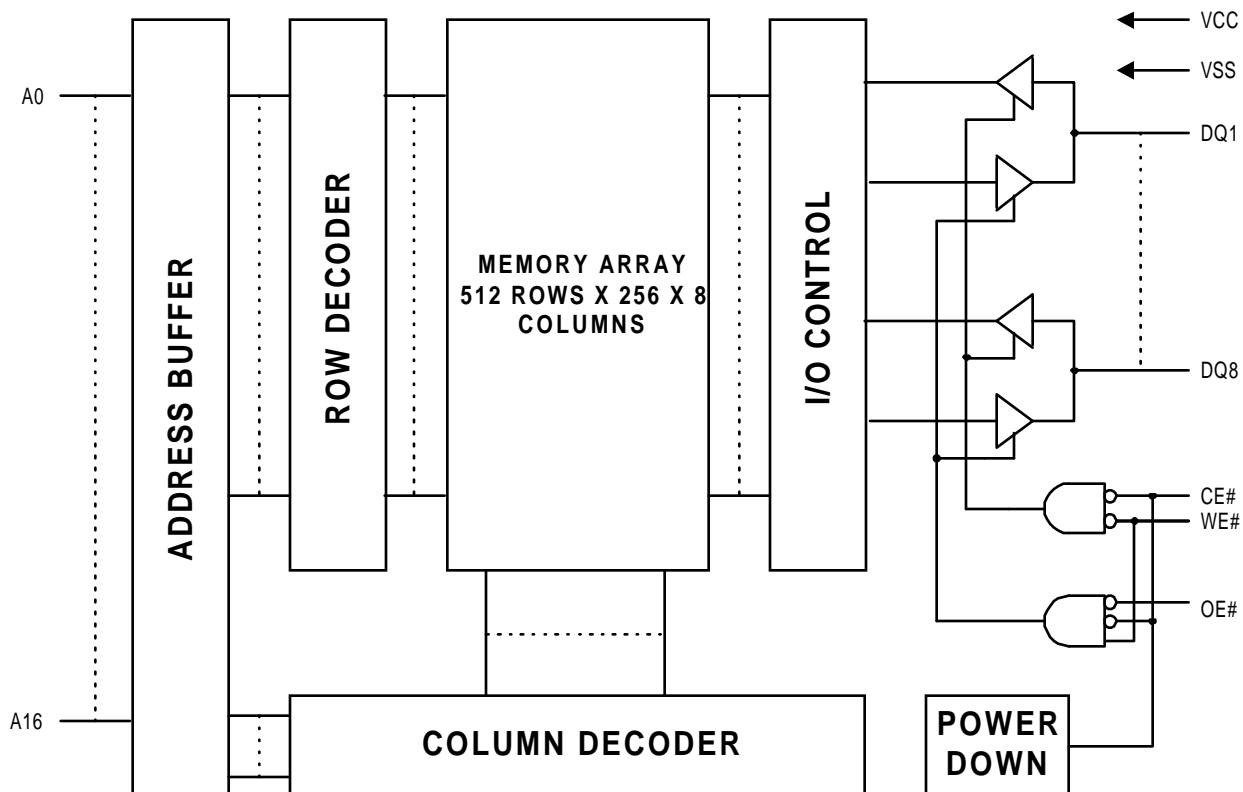

## TRUTH TABLE

MODE	CE#	WE#	OE#	DQ	POWER
READ	L	H	L	Q	ACTIVE
WRITE	L	L	X	D	ACTIVE
OUTPUT DISABLE	L	H	H	HIGH-Z	ACTIVE
STANDBY	H	X	X	HIGH-Z	STANDBY

## PIN DESCRIPTIONS

SOJ Pin Numbers	SYMBOL	TYPE	DESCRIPTION
4, 3, 2, 1, 32, 31, 30, 29, 21, 20, 19, 18, 17, 16, 15, 14, 13	A0-A16	Input	Addresses Inputs: These inputs determine which cell is addressed.
12	WE#	Input	Write Enable: This input determines if the cycle is a READ or WRITE cycle. WE# is LOW for a WRITE cycle and HIGH for a READ cycle.
5	CE#	Input	Chip Enable: This active LOW input is used to enable the device. When CE# is LOW, the chip is selected. When CE# is HIGH, the chip is disabled and automatically goes into standby power mode.
28	OE#	Input	Output Enable: This active LOW input enables the output drivers.
6, 7, 10, 11, 22, 23, 26, 27	DQ1-DQ8	Input/Output	SRAM Data I/O: Data inputs and data outputs
8, 24	VCC	Supply	Power Supply: 5V $\pm$ 10%
9, 25	VSS	Supply	Ground

### ABSOLUTE MAXIMUM RATINGS\*

Voltage on VCC Supply Relative to VSS.....	-0.5V to +7.0V
V <sub>IN</sub> .....	-0.5V to VCC+0.5V
Storage Temperature (plastic) .....	-55°C to +125°
Junction Temperature .....	+125°
Power Dissipation .....	1.2W
Short Circuit Output Current .....	50mA

\*Stresses greater than those listed under “Absolute Maximum Ratings” may cause permanent damage to the device. This is a stress rating only and functional operation of the device at these or any other conditions above those indicated in the operational sections of this specification is not implied. Exposure to absolute maximum rating conditions for extended periods may affect reliability.

### DC ELECTRICAL CHARACTERISTICS AND RECOMMENDED OPERATING CONDITIONS

(All Temperature Ranges; VCC = 5V ±10% unless otherwise noted)

DESCRIPTION	CONDITIONS	SYMBOL	MIN	MAX	UNITS	NOTES
Input High (Logic 1) voltage		V <sub>IH</sub>	2.2	VCC+1	V	1, 2
Input Low (Logic 0) Voltage		V <sub>IL</sub>	-0.5	0.8	V	1, 2
Input Leakage Current	0V ≤ V <sub>IN</sub> ≤ VCC	I <sub>L1</sub>	-5	5	uA	
Output Leakage Current	Output(s) disabled, 0V ≤ V <sub>OUT</sub> ≤ VCC	I <sub>LO</sub>	-5	5	uA	
Output High Voltage	I <sub>OH</sub> = -4.0mA	V <sub>OH</sub>	2.4		V	1
Output Low Voltage	I <sub>OL</sub> = 8.0mA	V <sub>OL</sub>		0.4	V	1
Supply Voltage		VCC	4.5	5.5	V	1

DESCRIPTION	CONDITIONS	SYM	TYP	POWER	-10	-12	-15	-20	UNITS	NOTES
Power Supply Current: Operating	Device selected; CE# ≤ V <sub>IL</sub> ; VCC = MAX; f=f <sub>MAX</sub> ; outputs open	I <sub>CC</sub>	80	standard	210	180	150	110	mA	3, 14
				low	200	170	140	110		
TTL Standby	CE# ≥ V <sub>IH</sub> ; VCC = MAX; f=f <sub>MAX</sub>	I <sub>SB1</sub>	20	standard	60	55	50	40	mA	14
				low	45	40	35	30		
CMOS Standby	CE1# ≥ VCC -0.2; VCC = MAX; all other inputs ≤ VSS +0.2 or ≥ VCC -0.2; all inputs static; f= 0	I <sub>SB2</sub>	0.02	standard	5	5	5	5	mA	14
				low	0.4	0.4	0.4	0.4		

### CAPACITANCE

DESCRIPTION	CONDITIONS	SYMBOL	MAX	UNITS	NOTES
Input Capacitance	T <sub>A</sub> = 25°C; f = 1 MHz VCC = 5V	C <sub>I</sub>	6	pF	4
Input/Output Capacitance (DQ)		C <sub>I/O</sub>	8	pF	4

## AC ELECTRICAL CHARACTERISTICS

(Note 5) (All Temperature Ranges; VCC = 5V ±10%)

DESCRIPTION	SYM	- 10		- 12		- 15		- 20		UNITS	NOTES
		MIN	MAX	MIN	MAX	MIN	MAX	MIN	MAX		
<b>READ Cycle</b>											
READ cycle time	<sup>t</sup> RC	10		12		15		20		ns	
Address access time	<sup>t</sup> AA		10		12		15		20	ns	
Chip Enable access time	<sup>t</sup> ACE		10		12		15		20	ns	
Output hold from address change	<sup>t</sup> OH	3		4		4		4		ns	
Chip Enable to output in Low-Z	<sup>t</sup> LZCE	3		4		4		4		ns	4, 7
Chip disable to output in High-Z	<sup>t</sup> HZCE		5		6		7		8	ns	4, 6, 7
Output Enable access time	<sup>t</sup> AOE		5		6		7		8	ns	
Output Enable to output in Low-Z	<sup>t</sup> LZOE	0		0		0		0		ns	
Output Enable to output in High-Z	<sup>t</sup> HZOE		5		6		7		8	ns	4, 6
Chip Enable to power-up time	<sup>t</sup> PU	0		0		0		0		ns	4
Chip disable to power-down time	<sup>t</sup> PD		10		12		15		20	ns	4
<b>WRITE Cycle</b>											
WRITE cycle time	<sup>t</sup> WC	10		12		15		20		ns	
Chip Enable to end of write	<sup>t</sup> CW	8		8		9		10		ns	
Address valid to end of write, with OE# HIGH	<sup>t</sup> AW	8		8		9		10		ns	
Address setup time	<sup>t</sup> AS	0		0		0		0		ns	
Address hold from end of write	<sup>t</sup> AH	0		0		0		0		ns	
WRITE pulse width	<sup>t</sup> WP2	10		10		11		12		ns	
WRITE pulse width, with OE# HIGH	<sup>t</sup> WP1	8		8		9		10		ns	
Data setup time	<sup>t</sup> DS	6		6		7		8		ns	
Data hold time	<sup>t</sup> DH	0		0		0		0		ns	
Write disable to output in Low-Z	<sup>t</sup> LZWE	3		4		5		5		ns	4, 7
Write Enable to output in High-Z	<sup>t</sup> HZWE		5		6		7		8	ns	4, 6, 7

### AC TEST CONDITIONS

Input pulse levels	0V to 3.0V
Input rise and fall times	1.5ns
Input timing reference levels	1.5V
Output reference levels	1.5V
Output load	See Figures 1 and 2

### OUTPUT LOADS

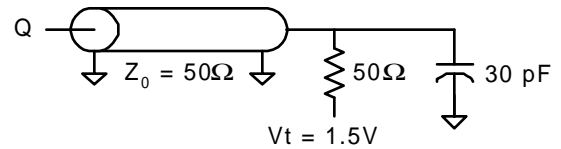

Fig. 1 OUTPUT LOAD EQUIVALENT

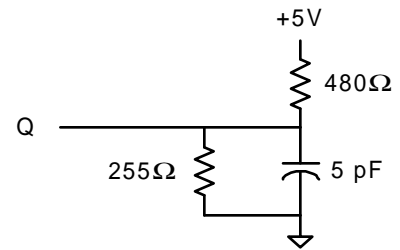

Fig. 2 OUTPUT LOAD EQUIVALENT

### NOTES

- All voltages referenced to VSS (GND).
- Overshoot:  $V_{IH} \leq +7.0V$  for  $t \leq t_{RC}/2$ .  
Undershoot:  $V_{IL} \leq -2.0V$  for  $t \leq t_{RC}/2$
- $I_{CC}$  is given with no output current.  $I_{CC}$  increases with greater output loading and faster cycle times.
- This parameter is sampled.
- Test conditions as specified with the output loading as shown in Fig. 1 unless otherwise noted.
- Output loading is specified with  $C_L=5pF$  as in Fig. 2. Transition is measured  $\pm 500mV$  from steady state voltage.
- At any given temperature and voltage condition,  $t_{HZCE}$  is less than  $t_{LZCE}$  and  $t_{HZWE}$  is less than  $t_{LZWE}$ .
- $WE\#$  is HIGH for READ cycle.
- Device is continuously selected. Chip enable and output enables are held in their active state.
- Address valid prior to, or coincident with, latest occurring chip enable.
- $t_{RC}$  = Read Cycle Time.
- Chip Enable and Write Enable can initiate and terminate a WRITE cycle.
- Capacitance derating applies to capacitance different from the load capacitance shown in Fig. 1.
- Typical values are measured at 5V, 25°C and 20ns cycle time.

### DATA RETENTION ELECTRICAL CHARACTERISTICS (L Version Only)

DESCRIPTION	CONDITIONS	SYMBOL	MIN	TYP	MAX	UNITS	NOTES
Vcc for Retention Data		$V_{DR}$	2			V	
Data Retention Current	CE# >VCC -0.2; all other inputs $\leq$ VSS +0.2 or $\geq$ VCC -0.2; all inputs static; f= 0	Vcc = 2V		2	100	$\mu A$	13
		Vcc = 3V		3	150	$\mu A$	13
Chip Deselect to Data Retention Time		$t_{CDR}$	0			ns	4
Operation Recovery Time		$t_{tr}$	$t_{RC}$			ns	4, 11

## LOW VCC DATA RETENTION WAVEFORM

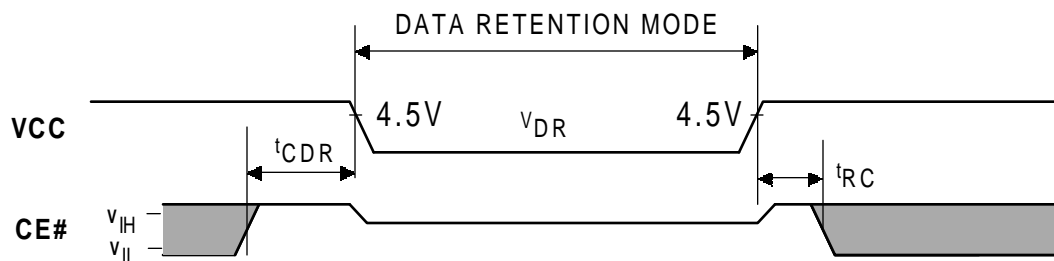

## READ CYCLE NO. 1<sup>(8, 9)</sup>

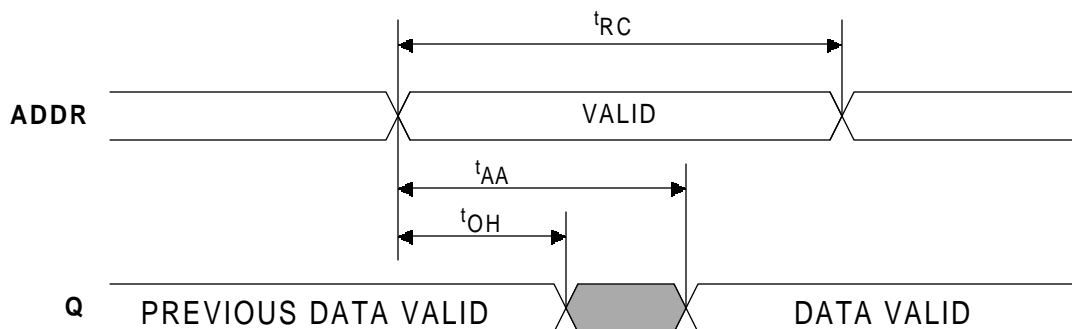

## READ CYCLE NO. 2<sup>(7, 8, 10, 12)</sup>

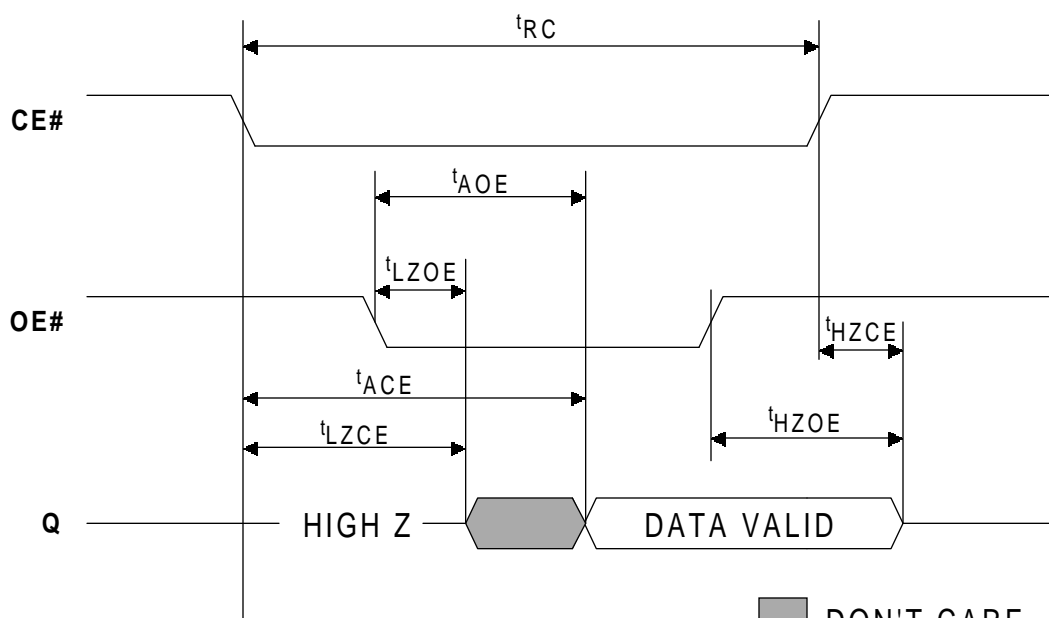

■ DON'T CARE

■ UNDEFINED

### WRITE CYCLE NO. 1 (7, 12, 13)

(Write Enable Controlled with Output Enable OE# active LOW)

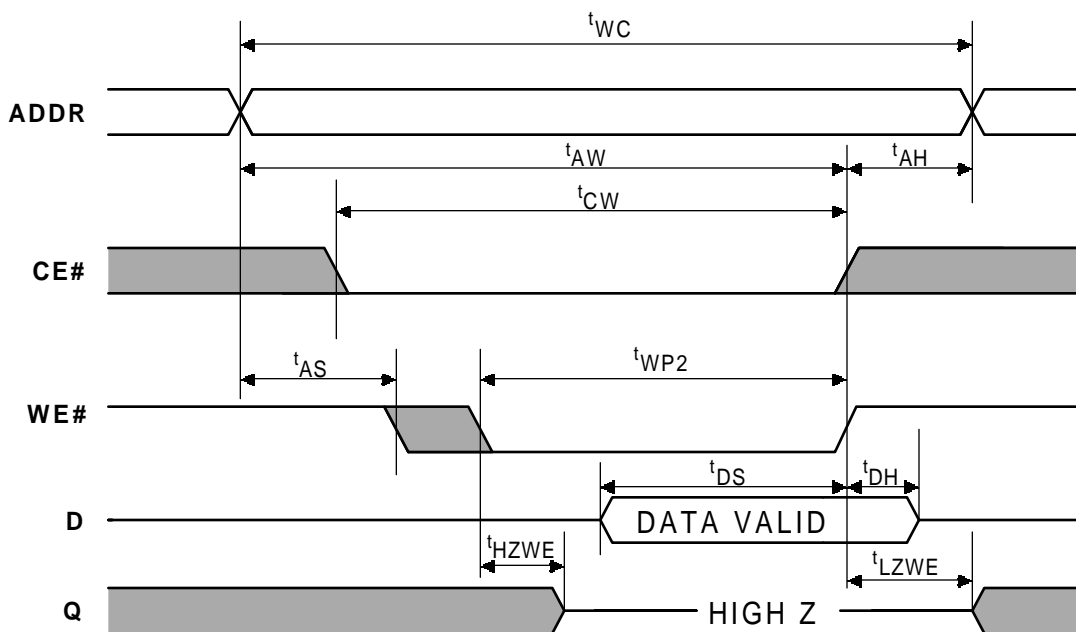

### WRITE CYCLE NO. 2 (12, 13)

(Write Enable Controlled with Output Enable OE# inactive HIGH)

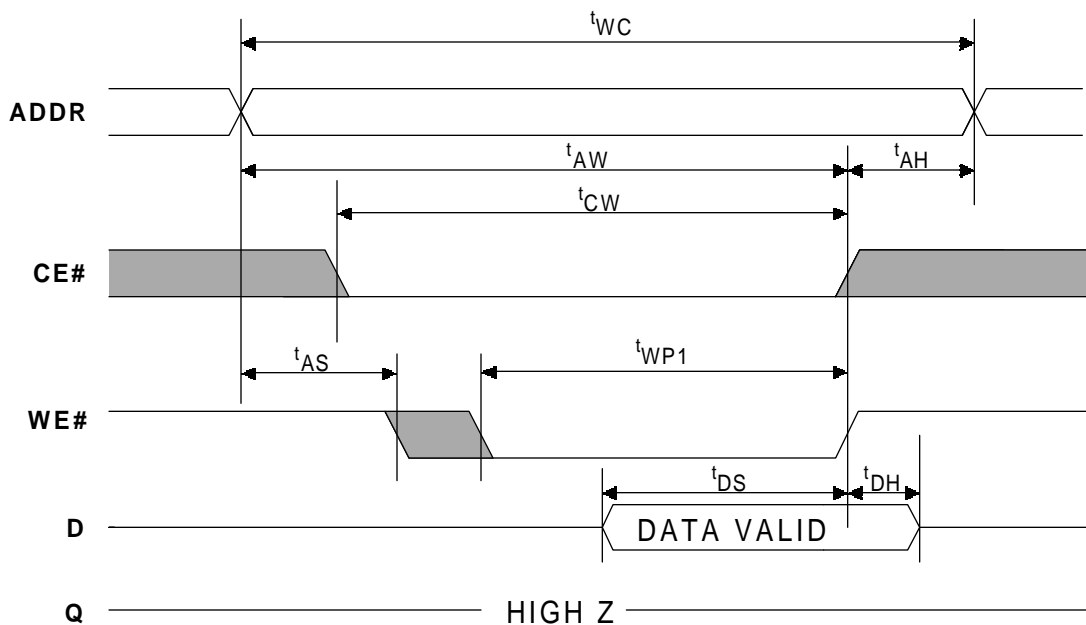

DON'T CARE  
 UNDEFINED

**WRITE CYCLE NO. 3** <sup>(12, 13)</sup>  
 (Chip Enable Controlled)

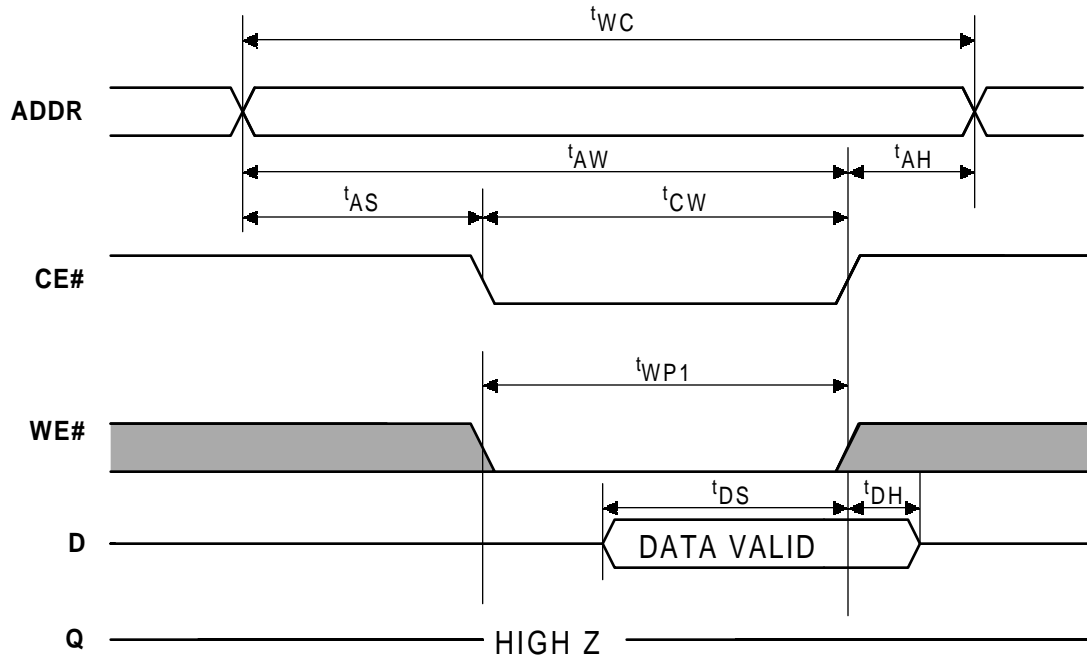

■ DON'T CARE



## Package Dimensions

### 32-pin 400 Mil Plastic SOJ (J)

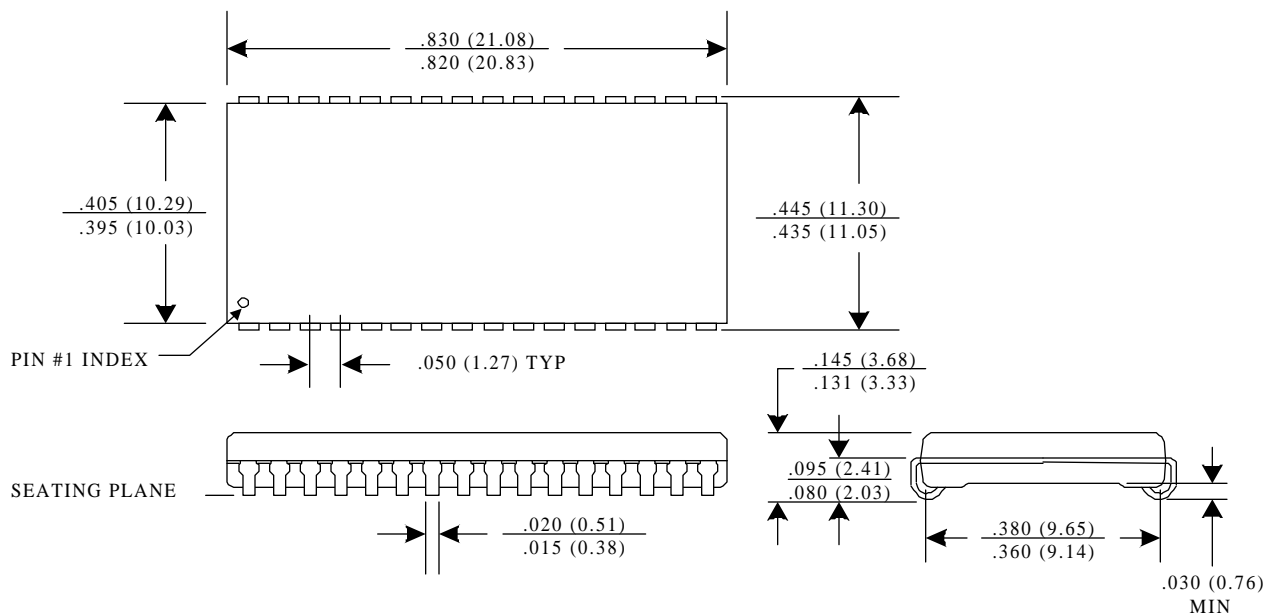

Note: All dimensions in inches (millimeters)  $\frac{\text{MAX}}{\text{MIN}}$  or typical, min where noted.

### 32-pin 300 Mil Plastic SOJ (SJ)

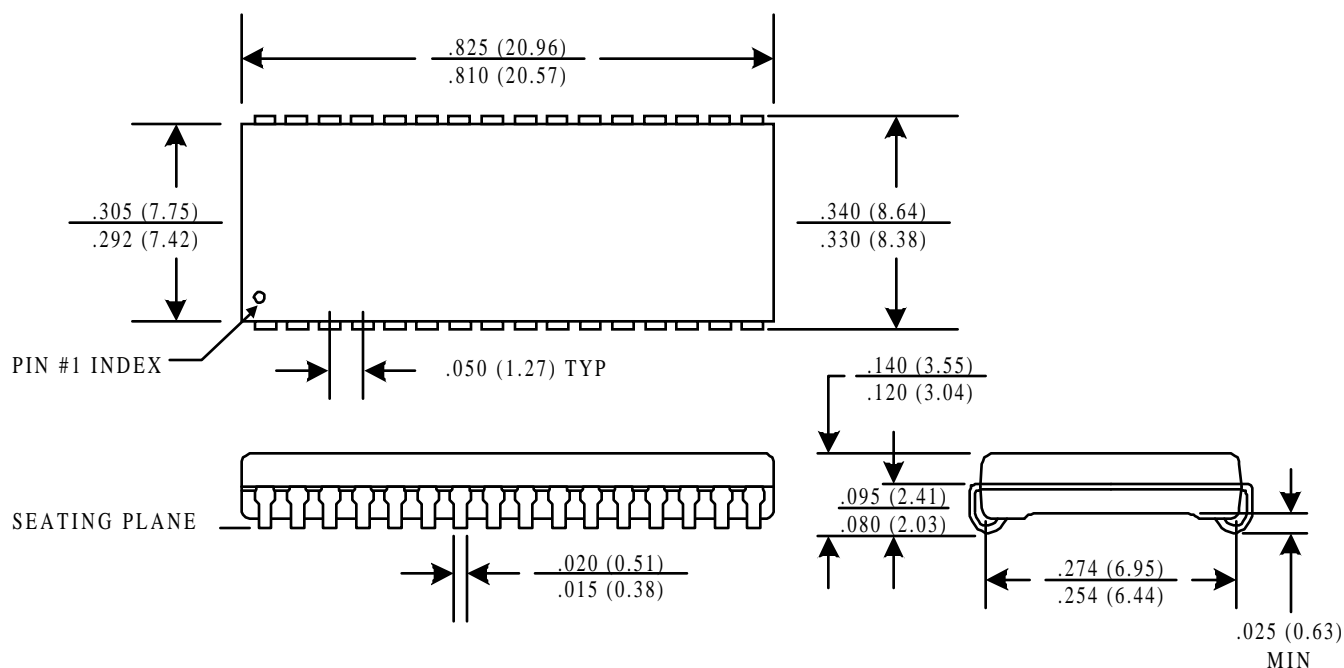

Note: All dimensions in inches (millimeters)  $\frac{\text{MAX}}{\text{MIN}}$  or typical, min where noted.

## Ordering Information

**GVT 72128A8 XX - XX X X**

Galvantech Prefix

Part Number

Temperature (Blank = Commercial  
I = Industrial)

Power (Blank= Standard,  
L= Low Power)

Speed (10 = 10ns, 12= 12ns  
15 = 15ns, 20 = 20ns)

Package (J = 400 mil SOJ,  
SJ= 300 mil SOJ)