

PWM Buck Controller

■ Features

- PWM Buck Control Circuitry
- Operating voltage can be up to 27V
- Under voltage Lockout (UVLO) Protection
- Short Circuit Protection (SCP)
- Soft-start circuit
- Variable Oscillator Frequency -- 300Khz Max
- 1.25V voltage reference Output
- 8-pin PDIP and SOP packages

■ Applications

- Backlight inverter
- LCD Monitor
- XDRom, XDSL Product
- DC/DC converters in computers, etc.

■ Pin Assignment

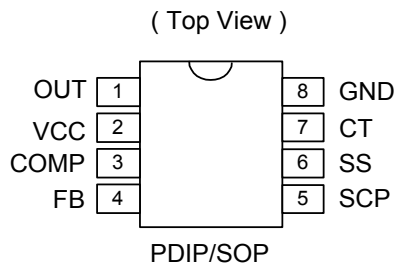

■ General Description

The AP2004 integrates Pulse-Width-Modulation (PWM) control circuit into a single chip, mainly designs for power-supply regulator. All the functions include an on-chip 1.25V reference output, an error amplifier, an adjustable oscillator, a soft-start, UVLO, SCP circuitry, and a push-pull output circuit. Switching frequency is adjustable by trimming CT. During low VCC situation, the UVLO makes sure that the outputs are off until the internal circuit operates normally.

■ Pin Descriptions

Name	Description
CT	Timing Capacitor
FB	Voltage Feedback
SS	Soft-Start.
COMP	Feedback Loop Compensation
OUT	PWM Output
GND	Ground
VCC	Supply Voltage
SCP	Short Circuit Protection

■ Ordering Information

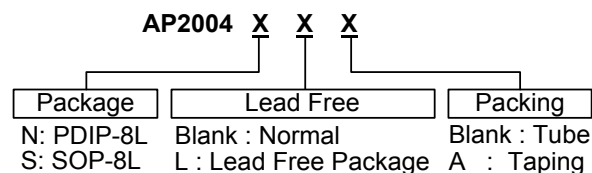

■ Block Diagram

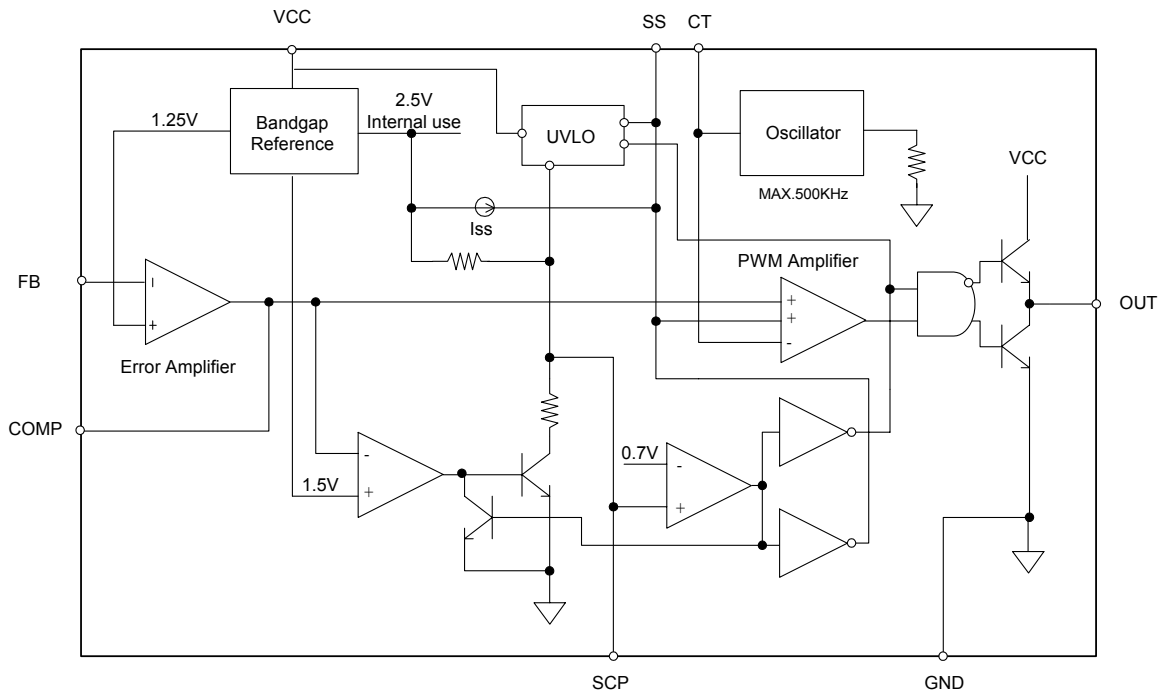

■ Absolute Maximum Ratings

Symbol	Parameter	Rating	Unit
V_{CC}	Supply voltage	28	V
V_I	Amplifier input voltage	20	V
V_O	Collector output voltage	$V_{CC}-1.0V$	V
I_{SOURCE}	Source current	200	mA
I_{SINK}	Sink current	200	mA
T_{OP}	Operating temperature range	-20 to +85	°C
T_{ST}	Storage temperature range	-65 to +150	°C
T_{LEAD}	Lead temperature 1.6 mm(1/16 inch) from case for 10 seconds	260	°C



■ Recommended Operating Conditions

Symbol	Parameter	Min.	Max.	Unit
V_{CC}	Supply voltage	3.6	27	V
V_I	Amplifier input voltage	1.05	1.45	V
V_O	Collector output voltage		$V_{CC}-1.5$	V
I_{FB}	Current into feedback terminal		45	μA
R_F	Feedback resistor	100		$k\Omega$
C_T	Timing capacitor	100	6800	pF
F_{OSC}	Oscillator frequency	10	300	KHz
T_{OP}	Operating free-air temperature	-20	85	$^{\circ}C$

■ Electrical Characteristics ($T_A=25^{\circ}C$, $V_{CC}=6V$, $f=200$ KHz)

Reference (REF)

Symbol	Parameter	Conditions	Min.	Typ.	Max.	Unit
V_{REF}	Comp connect to FB		1.225	1.25	1.275	V
	Output voltage change with temperature	$T_A = -20^{\circ}C \sim 25^{\circ}C$		-0.1	± 1	%
		$T_A = 25^{\circ}C \sim 85^{\circ}C$		-0.2	± 1	%

Under voltage lockout (UVLO)

Symbol	Parameter	Conditions	Min.	Typ.	Max.	Unit
V_{UT}	Upper threshold voltage (V_{CC})	$I_{O(REF)} = 0.1mA$ $T_A = 25^{\circ}C$		2.9		V
V_{LWT}	Lower threshold voltage (V_{CC})			2.4		V
V_{HT}	Hysteresis (V_{CC})			500		mV

Short-circuit protection (SCP) control

Symbol	Parameter	Conditions	Min.	Typ.	Max.	Unit
V_{IT}	Input threshold voltage	$T_A = 25^{\circ}C$	0.60	0.67	0.75	V
V_{STB}	Standby voltage	No pull up	100	130	160	mV
V_{LT}	Latched input voltage	No pull up		50	100	mV
I_{SCP}	Input (source) current	$V_I = 0.7V$, $T_A = 25^{\circ}C$	-10	-15	-20	μA
V_{CT}	Comparator threshold voltage (COMP)			1.5		V

Oscillator (OSC)

Symbol	Parameter	Conditions	Min.	Typ.	Max.	Unit
F_{OSC}	Frequency	$C_T = 270$ pF		200		KHz
ΔF_{OSC}	Standard deviation of frequency	$C_T = 270$ pF		10		%
	Frequency change with voltage	$V_{CC} = 3.6V \sim 20V$		1		

PWM Buck Controller

■ Electrical Characteristics (Continued) ($T_A=25^\circ\text{C}$, $V_{CC}=6\text{V}$, $f=200\text{KHz}$)

Error-amplifier

Symbol	Parameter	Conditions	Min.	Typ.	Max.	Unit
V_{IO}	Input offset voltage	$V_O(\text{FB})=1.25\text{V}$			± 6	mV
I_{IO}	Input offset current	$V_O(\text{FB})=1.25\text{V}$			± 100	nA
I_{IB}	Input bias current	$V_O(\text{FB})=1.25\text{V}$		160	500	nA
V_{CM}	Common-mode input voltage range	$V_{CC}=3.6\text{V} \sim 20\text{V}$	1.05		1.45	V
AV	Open-loop voltage amplification	$R_F=200\text{ k}\Omega$	70	80		dB
GBW	Unity-gain bandwidth			1.5		MHz
CMRR	Common-mode rejection ratio		60	80		dB
V_{OH}	Max. output voltage		$V_{ref}-0.1$			V
V_{OL}	Min. output voltage				1	V
I_{OI}	Output (sink) current (COMP)	$V_{ID} = -0.1\text{V}$, $V_O = 1.25\text{V}$	0.5	1.6		mA
I_{OO}	Output (source) current (COMP)	$V_{ID} = 0.1\text{V}$, $V_O = 1.25\text{V}$	-45	-70		μA

Output section

Symbol	Parameter	Conditions	Min.	Typ.	Max.	Unit
I_{LEAK}	Leakage current	$V_O = 25\text{V}$			10	μA
I_{DRV}	Sink current	$V_{IN} = 20\text{V}$		200		mA
	Source current	$V_{IN} = 20\text{V}$		200		mA
V_{SAT}	Output saturation voltage	$I_O = 10\text{ mA}$		1.0	1.5	V
I_{SC}	Short-circuit output current	$V_O = 6\text{V}$		120		mA

PWM comparator

Symbol	Parameter	Conditions	Min.	Typ.	Max.	Unit
V_{T0}	Input threshold voltage at $f = 10\text{ KHz}$ (COMP)	CT		0.6	0.7	V
V_{T100}		Maximum duty cycle	1.2	1.3		V

Total device

Symbol	Parameter	Conditions	Min.	Typ.	Max.	Unit
I_{CCA}	Average supply current	$C_T = 270\text{pF}$		6	10	mA

Soft Start

Symbol	Parameter	Conditions	Min.	Typ.	Max.	Unit
V_{SS}	Soft-start Voltage			2.3		V
I_{SS}	Constant Charge Current			20		μA

■ Typical Application Circuit

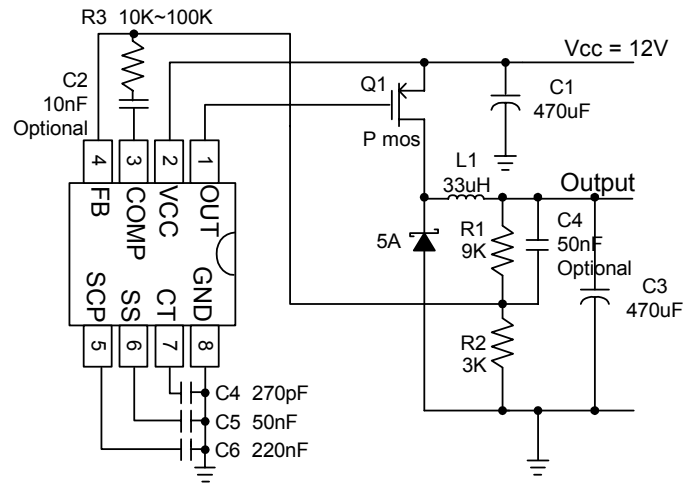

Step-Down DC/DC converter

■ Typical Characteristics

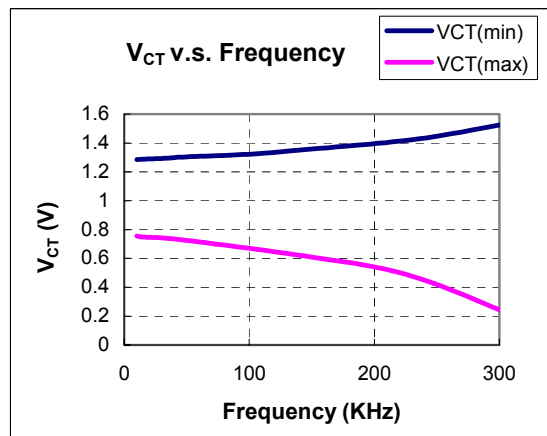
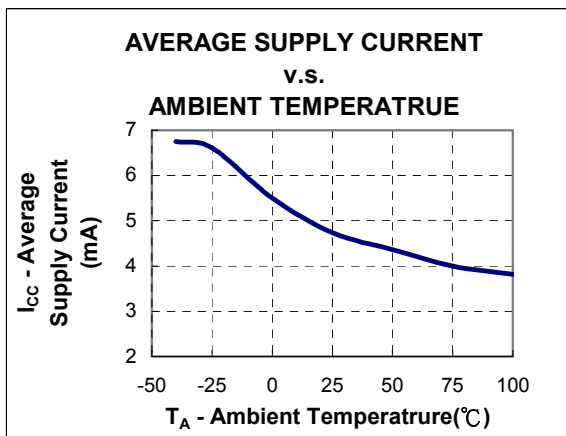
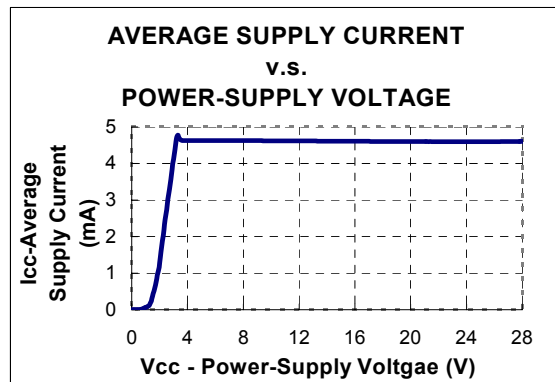
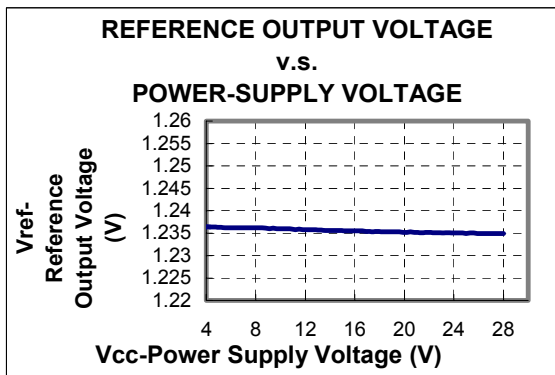

■ Typical Characteristics (Continued)

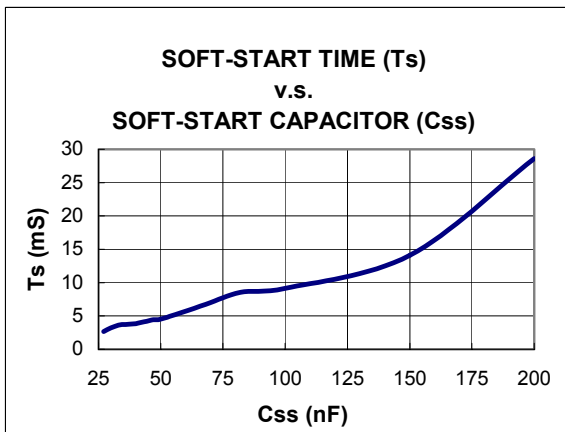
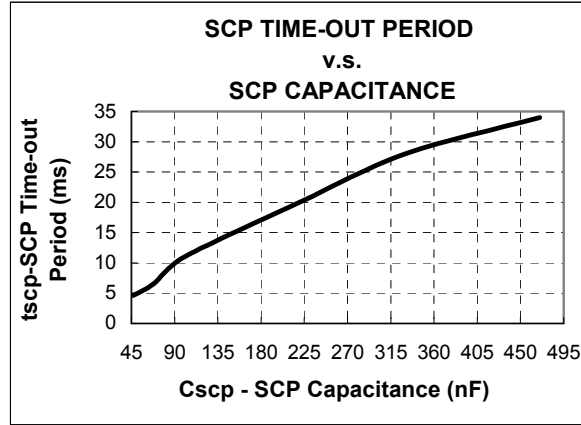
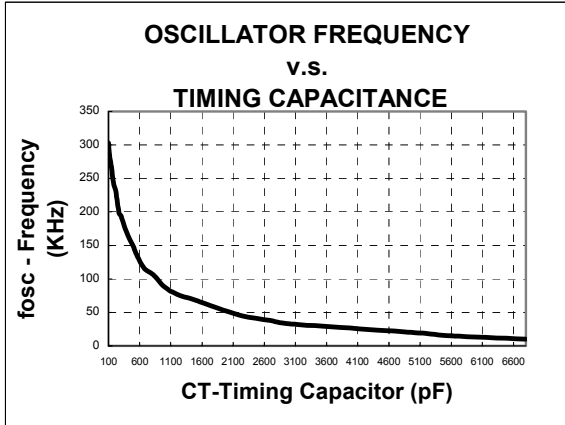

■ Marking Information

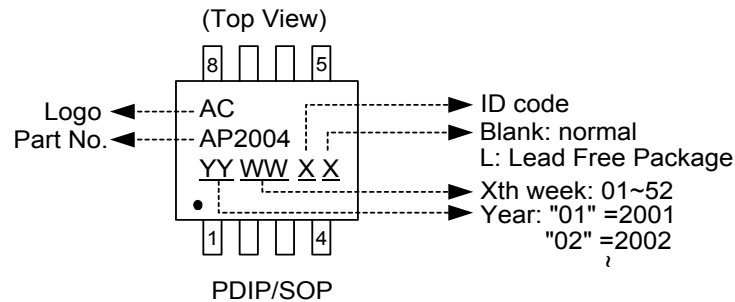

■ Package Information

(1) PDIP-8L (Plastic Dual-in-line Package)

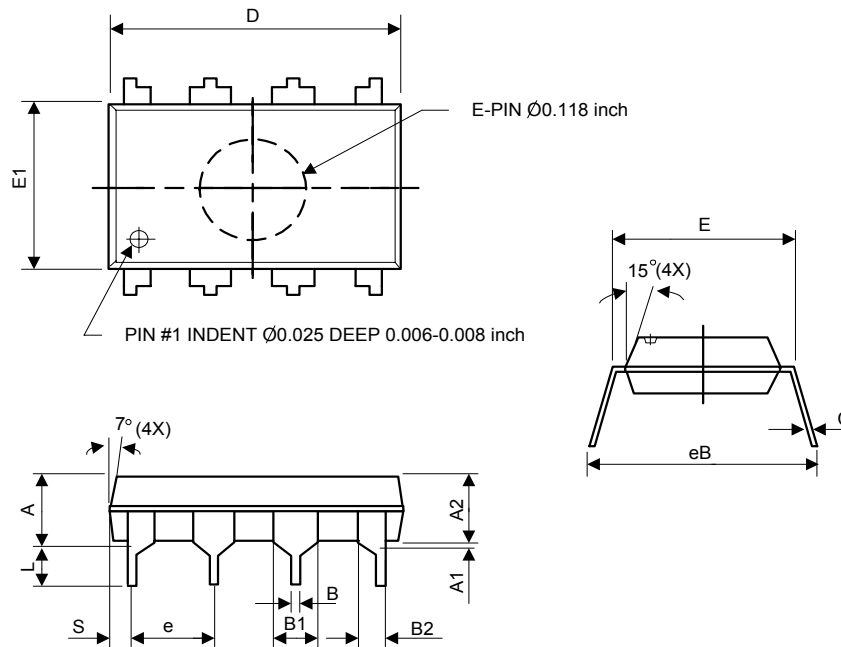

Symbol	Dimensions in millimeters			Dimensions in inches		
	Min.	Nom.	Max.	Min.	Nom.	Max.
A	-	-	5.33	-	-	0.210
A1	0.38	-	-	0.015	-	-
A2	3.1	3.30	3.5	0.122	0.130	0.138
B	0.36	0.46	0.56	0.014	0.018	0.022
B1	1.4	1.52	1.65	0.055	0.060	0.065
B2	0.81	0.99	1.14	0.032	0.039	0.045
C	0.20	0.25	0.36	0.008	0.010	0.014
D	9.02	9.27	9.53	0.355	0.365	0.375
E	7.62	7.94	8.26	0.300	0.313	0.325
E1	6.15	6.35	6.55	0.242	0.250	0.258
e	-	2.54	-	-	0.100	-
L	2.92	3.3	3.81	0.115	0.130	0.150
eB	8.38	8.89	9.40	0.330	0.350	0.370
S	0.71	0.84	0.97	0.028	0.033	0.038

■ Package Information (Continued)

(2) SOP- 8L(JEDEC Small Outline Package)

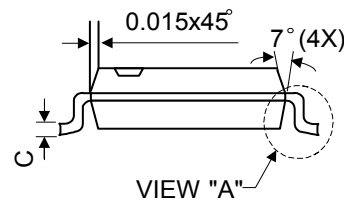
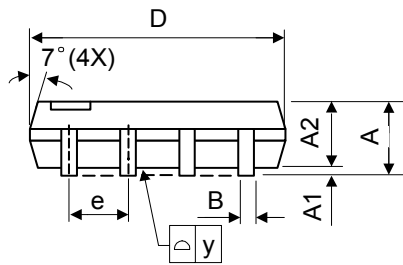
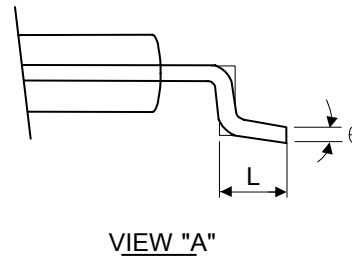
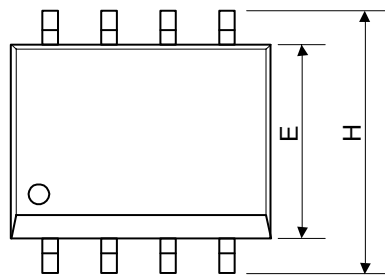

Symbol	Dimensions In Millimeters			Dimensions In Inches		
	Min.	Nom.	Max.	Min.	Nom.	Max.
A	1.40	1.60	1.75	0.055	0.063	0.069
A1	0.10	-	0.25	0.040	-	0.100
A2	1.30	1.45	1.50	0.051	0.057	0.059
B	0.33	0.41	0.51	0.013	0.016	0.020
C	0.19	0.20	0.25	0.0075	0.008	0.010
D	4.80	5.05	5.30	0.189	0.199	0.209
E	3.70	3.90	4.10	0.146	0.154	0.161
e	-	1.27	-	-	0.050	-
H	5.79	5.99	6.20	0.228	0.236	0.244
L	0.38	0.71	1.27	0.015	0.028	0.050
y	-	-	0.10	-	-	0.004
θ	0°	-	8°	0°	-	8°