

Features

- Single chip quadruple power splitter (primary channel, secondary channel, OOB channel and loop through)
- Wide dynamic range on all channels
- Independent AGC facility incorporated into all channel paths
- CSO, CTB, CXM all better than -62dBc for +3dBmV agc attack point
- Full ESD protection. (Normal ESD handling procedures should be observed)

Applications

- Multi-tuner cable set top box and cable modem applications
- Data communications systems
- Terrestrial TV tuner loop though

Description

The SL2150F is a wide dynamic range single chip power splitter for cable set top box multi-tuner applications.

The device offers four buffered outputs from a single input.

All signal paths contain an independently controllable AGC facility.

Ordering Information

SL2150F/KG/LH2S (tubes)
SL2150F/KG/LH2T (tape and reel)

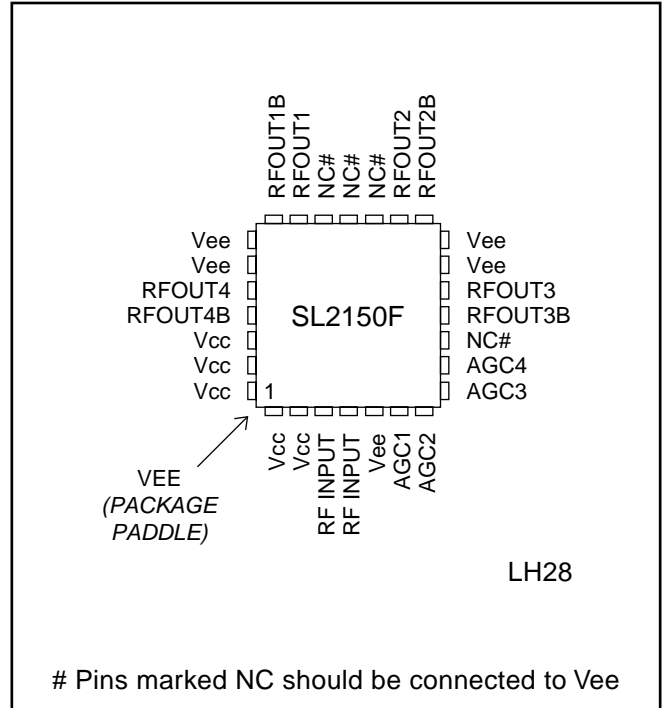

Figure 1 - Pin allocation

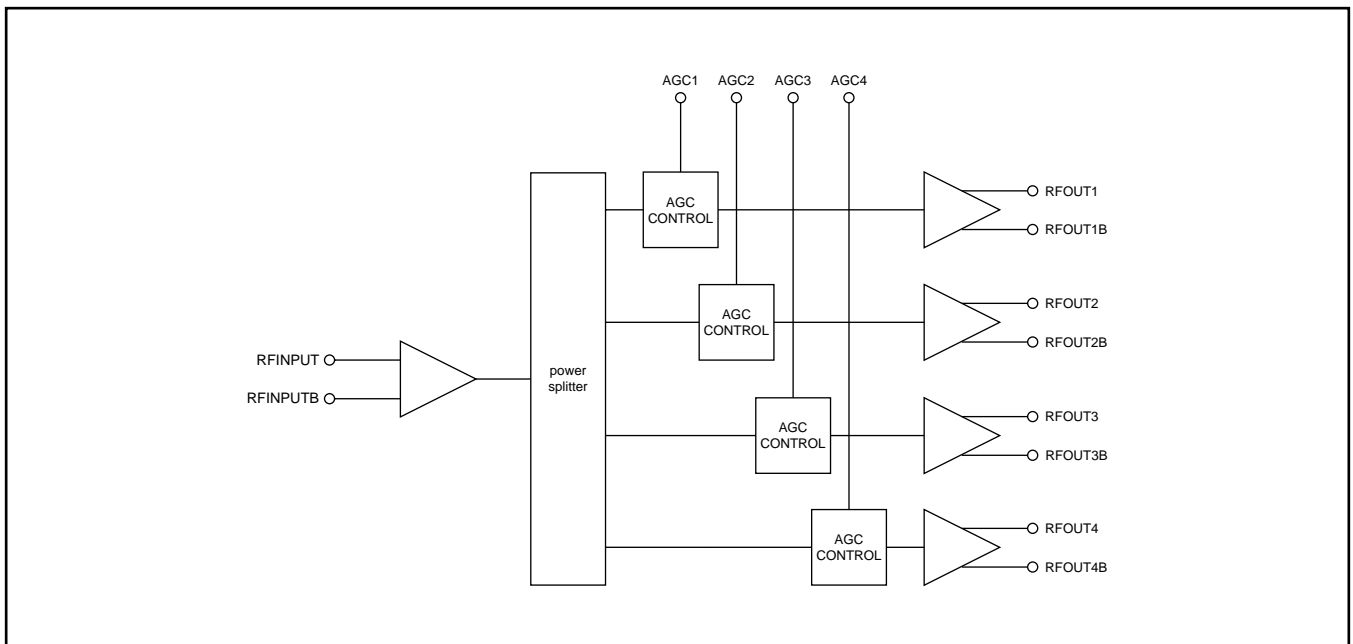

Figure 2 - SL2150F block diagram

Quick Reference Data

NB all data applies with differential termination and single ended source both of 75Ω

Characteristic		Units
RF input operating range	50-860	MHz
Conversion gain, with external load as in figure (12)		
maximum	5.5	dB
minimum	-25	dB
Input NF, all signal paths at maximum conversion gain	7	dB
IPIP3, all paths	127	dBμV
IPIP2, all paths	151	dBμV
CTB *	-66	dBc
CSO *	-64	dBc
CXM *	-66	dBc
Input impedance	75	Ω
Input VSWR	8	dB
Output impedance differential, all loops (requires external load for example as in figure (12))	440	Ω
Input to output isolation (all loops)	30	dB
Output to output isolation (all loops)	25	dB

* 132 channel matrix at +15 dBmV per channel, 75Ω source impedance, all paths, max gain

Functional Description

The SL2150F is a broadband wide dynamic range power splitter with AGC and is optimised for application in multi tuner cable set top box applications. It also has application in any system where a wide dynamic range broadband power splitter is required.

The pin assignment is contained in figure (1) and the block diagram in figure (2). The port internal peripheral circuits are contained in figure (14)

In normal application the RF input is interfaced to the device input. The input preamplifier is designed for low noise figure, within the operating region of 50 to 860 MHz and for high intermodulation distortion intercept so offering good signal to noise plus composite distortion spurious performance when loaded with a multi carrier system. The preamplifier when combined with the input network shown in figure (3) provides an impedance match to a 75Ω source. The typical impedance is shown in figure (4).

The input NF and input referred two-tone intermodulation test condition spectrum are shown in figures (5) and (6) respectively.

The output of the preamplifier is then power split to four independently controlled AGC stages.

Each AGC stage provides for a minimum of 30 dB of gain control across the input frequency range. The typical AGC characteristic and NF versus gain setting are contained in figures (7) and (8) respectively.

The input referred third order intercept point is independent of gain setting.

Finally each of the AGC stages drive an output buffer of nominal differential output impedance of 440Ω, which provides a nominal 5.5 dB of conversion gain when terminated into a differential 75Ω load.

In application it is important to avoid saturation of the output stage, therefore it is recommended that the output standing current be sunk to Vcc through an inductor. A resistive pull up can also be used as shown in figure (13b), however the resistor values should not exceed 38 ohm single ended.

If an inductive current sink is used the maximum available gain from the device is circa 20 dB. This gain can be reduced by application of an external load between the differential output ports. The gain can be approximately calculated from the following formula;

$$\text{GAIN} = 20 \cdot \log \left(\frac{\text{Parallel combination of } 440 \text{ ohm and external load between ports}}{44 \text{ ohm}} \right) + 2\text{dB}$$

For example when driving a 200 ohm load as in figure (13a), the gain equals;

$$\begin{aligned} \text{Gain} &= 20 \cdot \log \left(\frac{(440 \cdot 200)}{(440+200)/44} \right) + 2\text{dB} \\ &= 12\text{dB} \end{aligned}$$

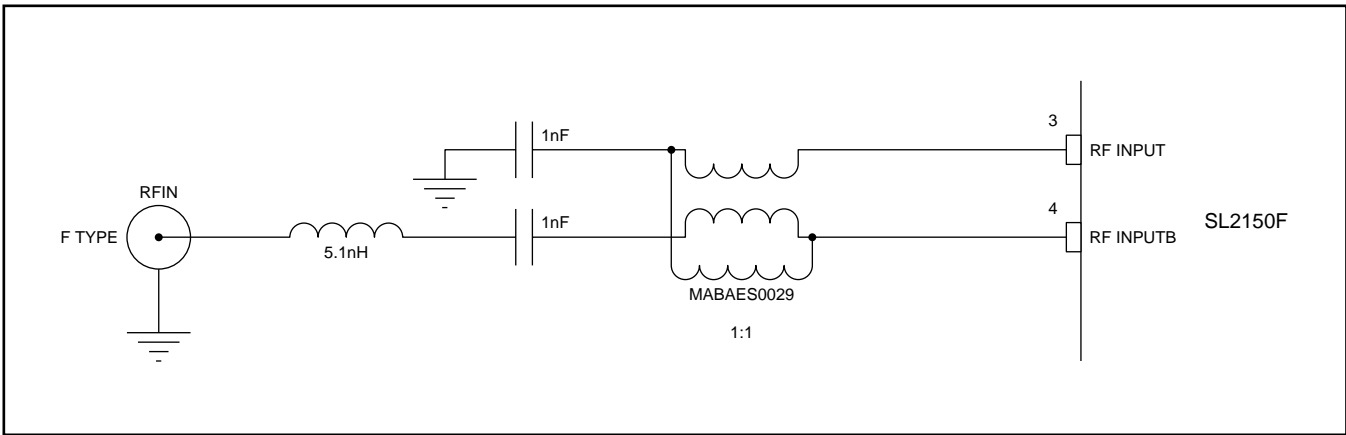

Figure 3 - RF input matching network

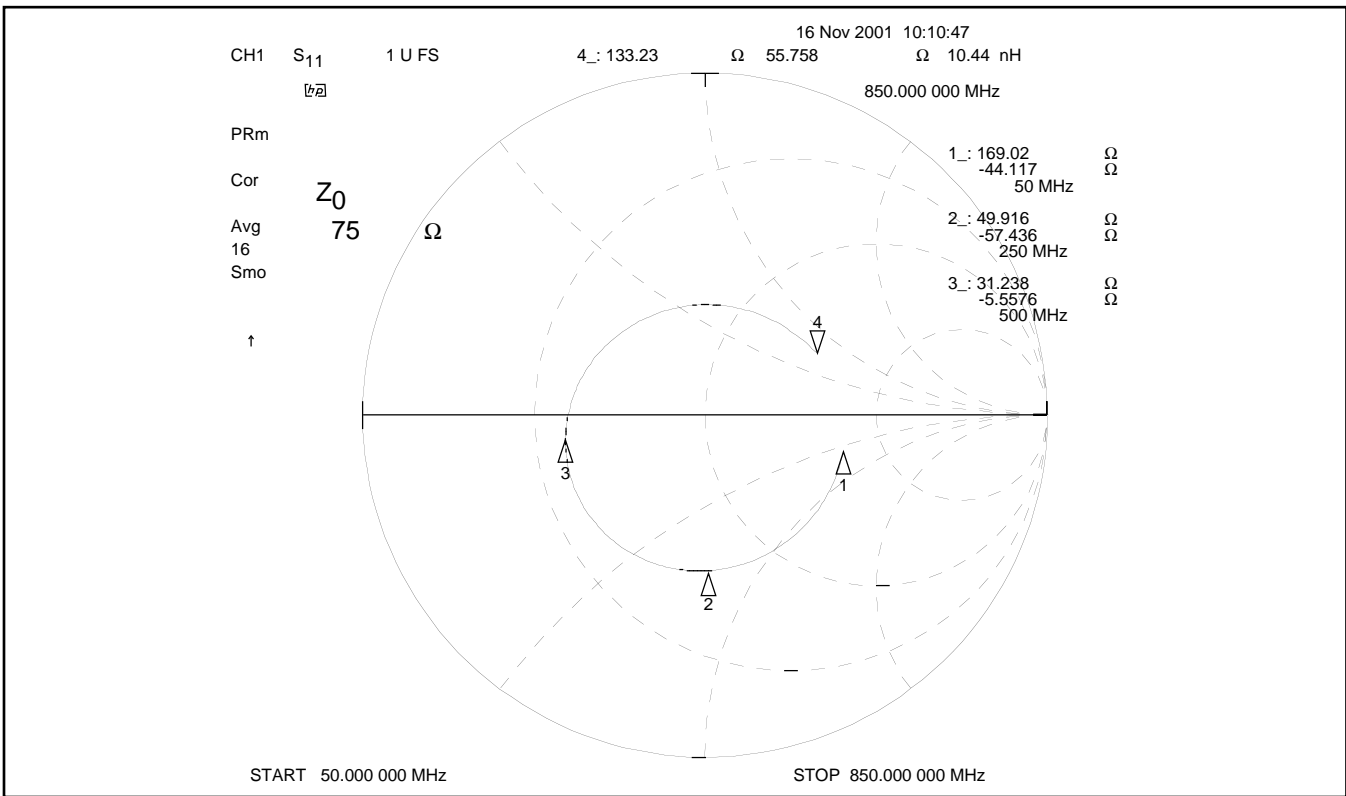

Figure 4 - Typical single-ended RF input impedance with input match

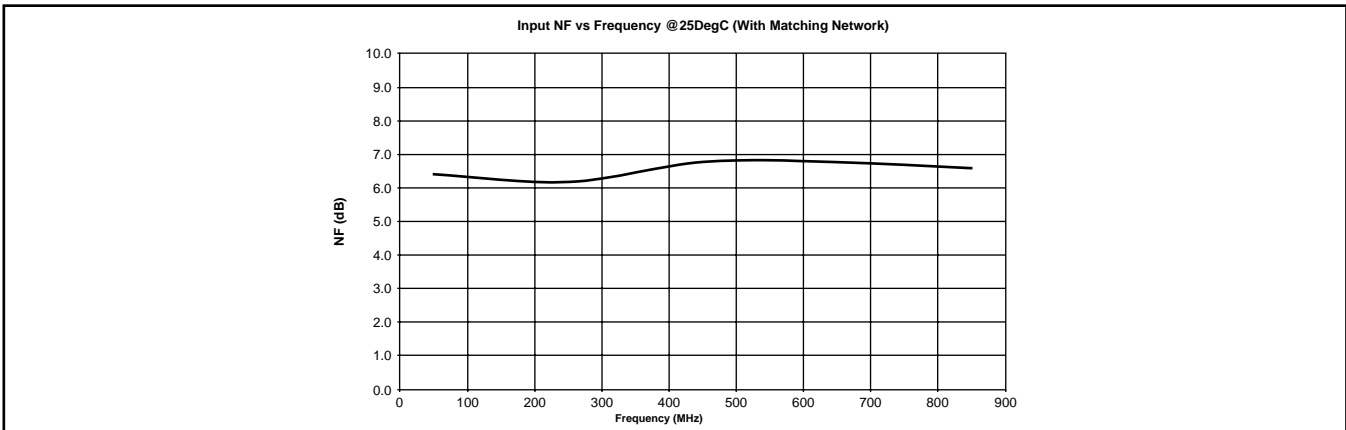

Figure 5 - Input NF at 25 deg C

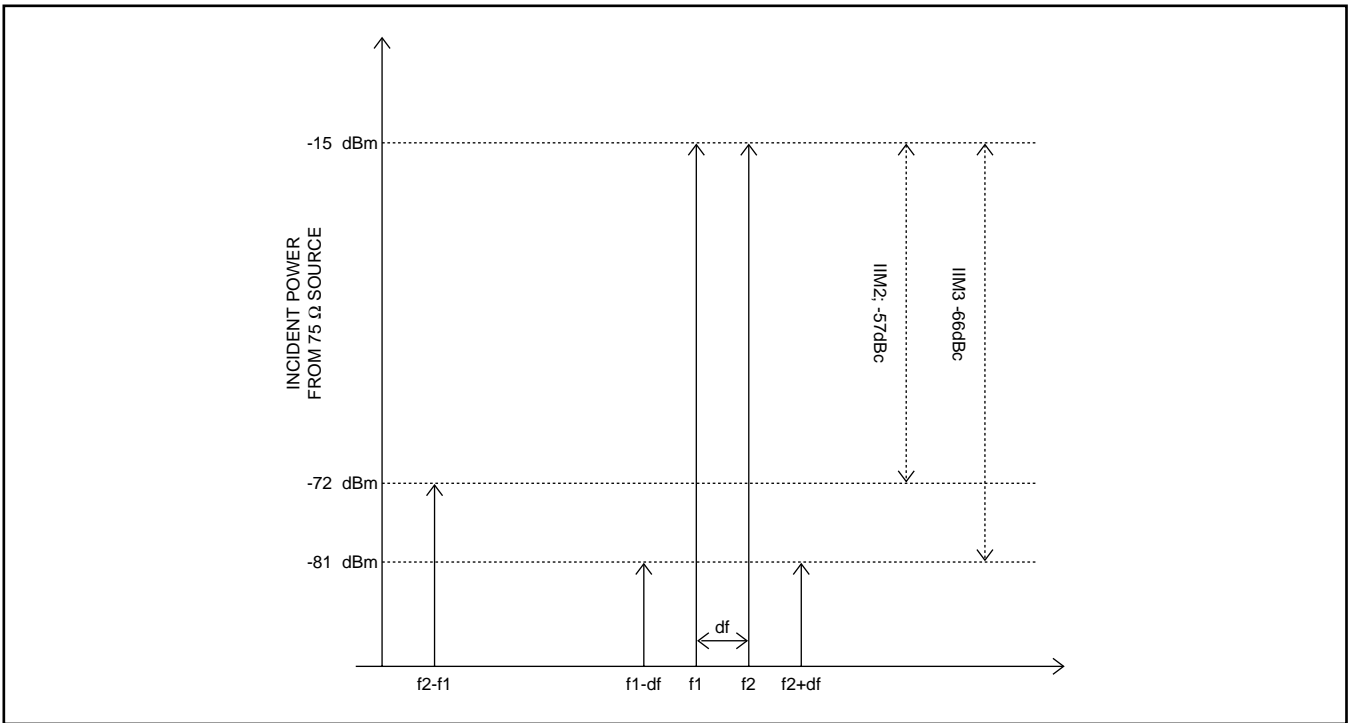

Figure 6 - Two tone intermodulation test condition spectrum, input referred

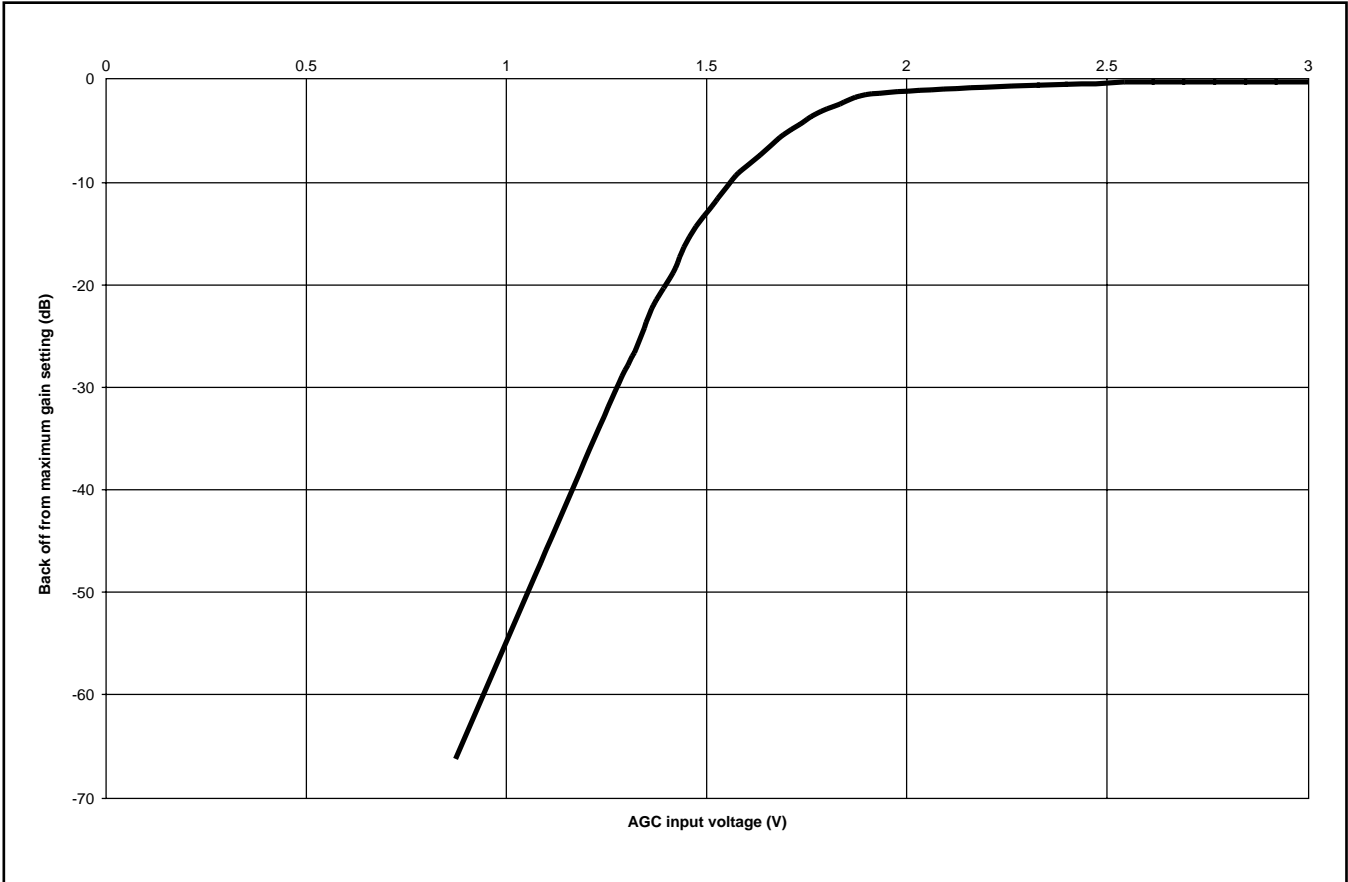

Figure 7 - Typical AGC versus control voltage characteristic

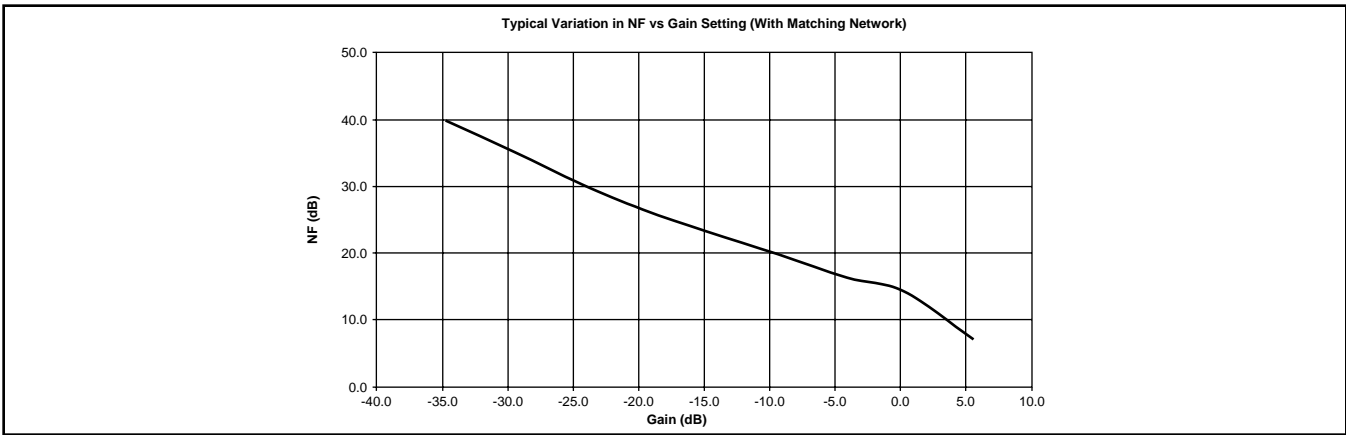

Figure 8 - Typical variation in NF versus gain setting

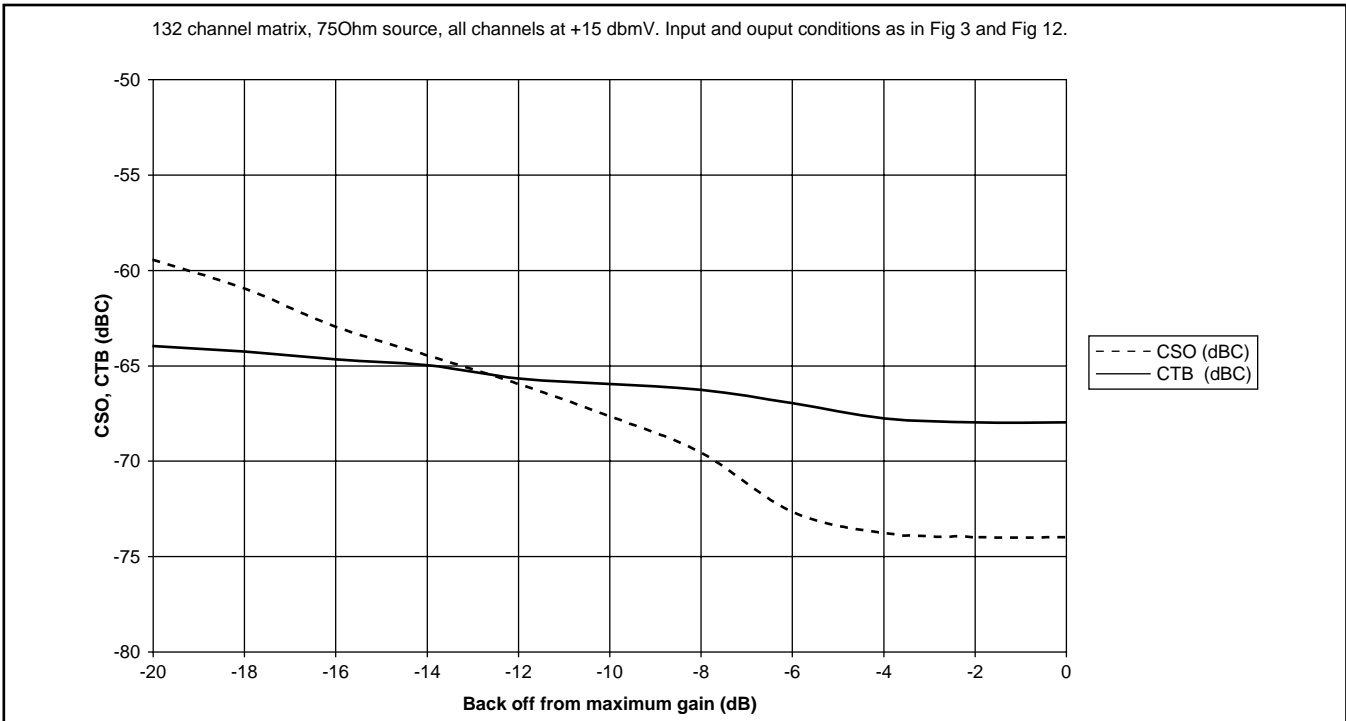

Figure 9 - Typical variation in CSO and CTB versus back off from maximum gain

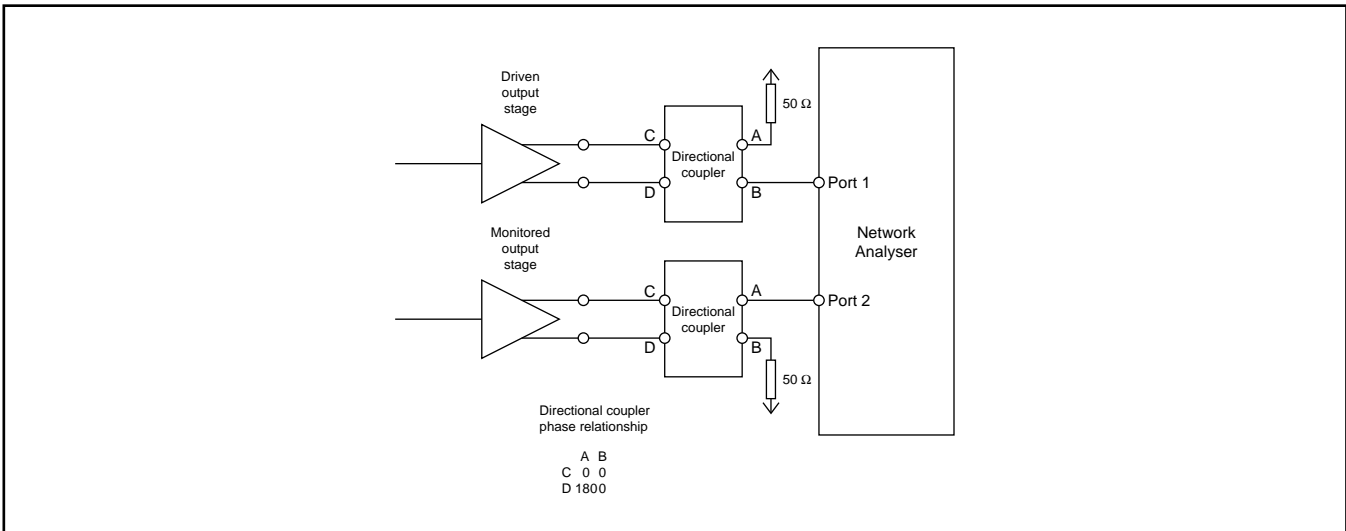

Figure 10 - Test condition for output crosstalk

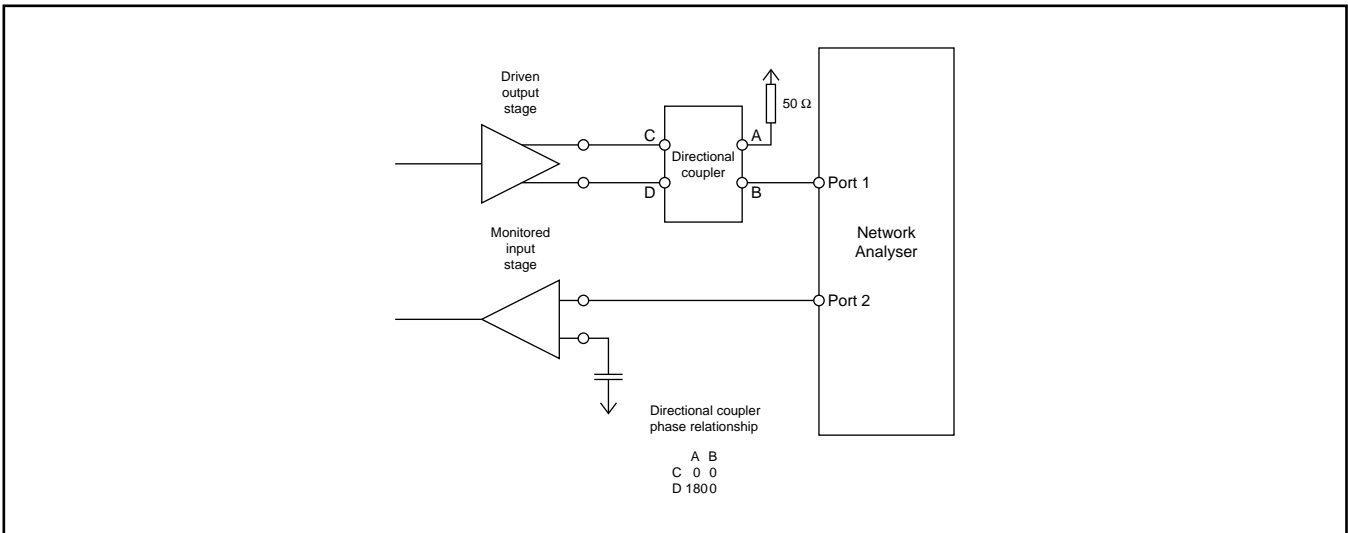

Figure 11 - Test condition for output to input crosstalk

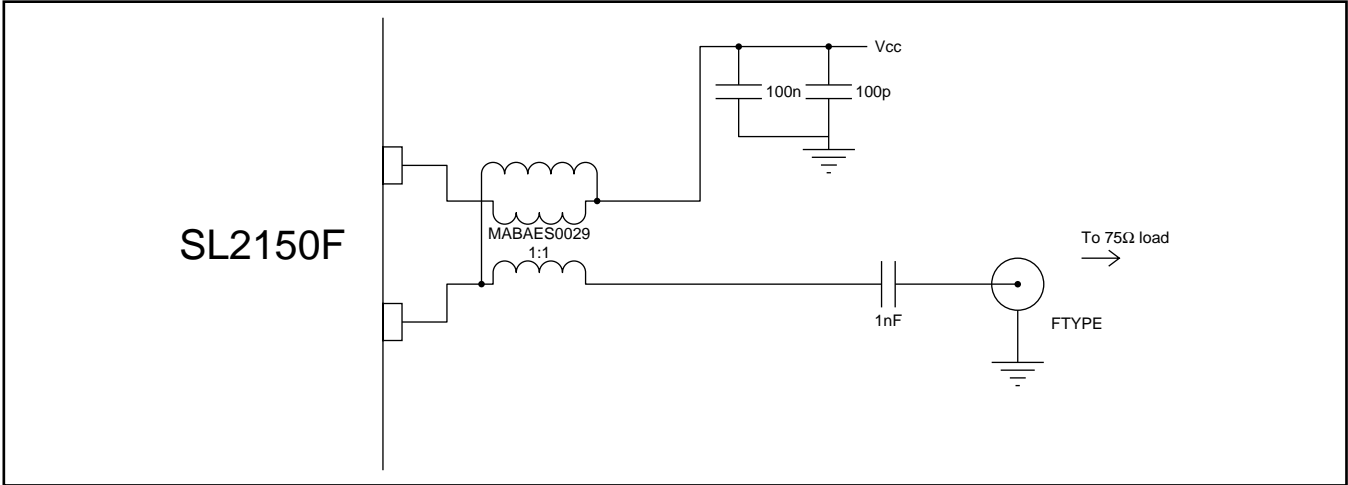

Figure 12 - Example application driving 75Ω load

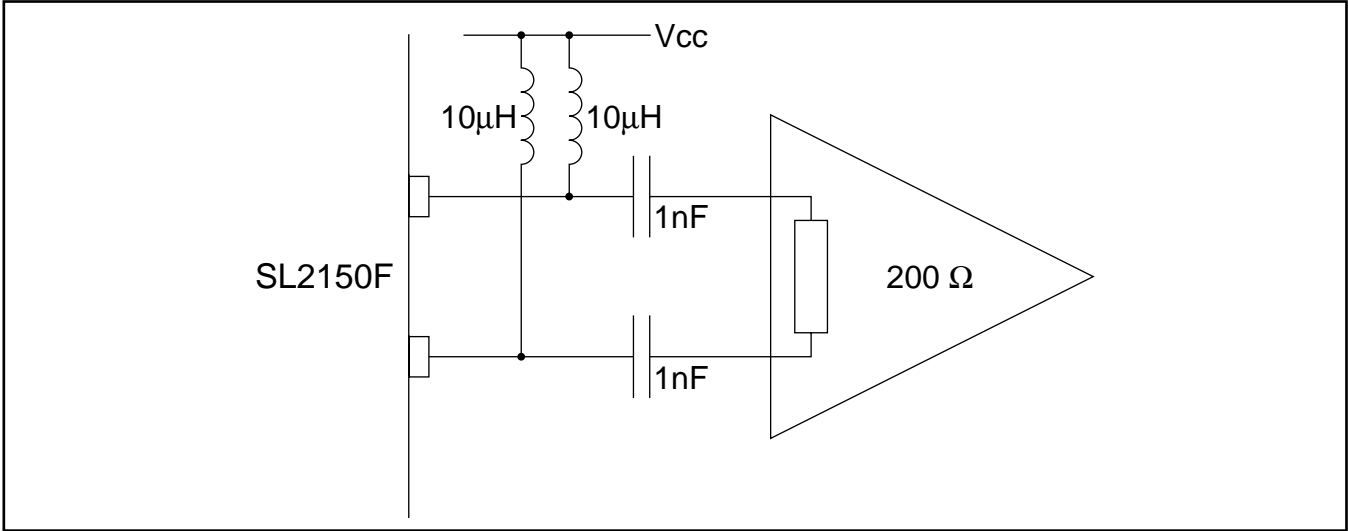

Figure 13a - Example application driving 200Ω load with inductive pull up

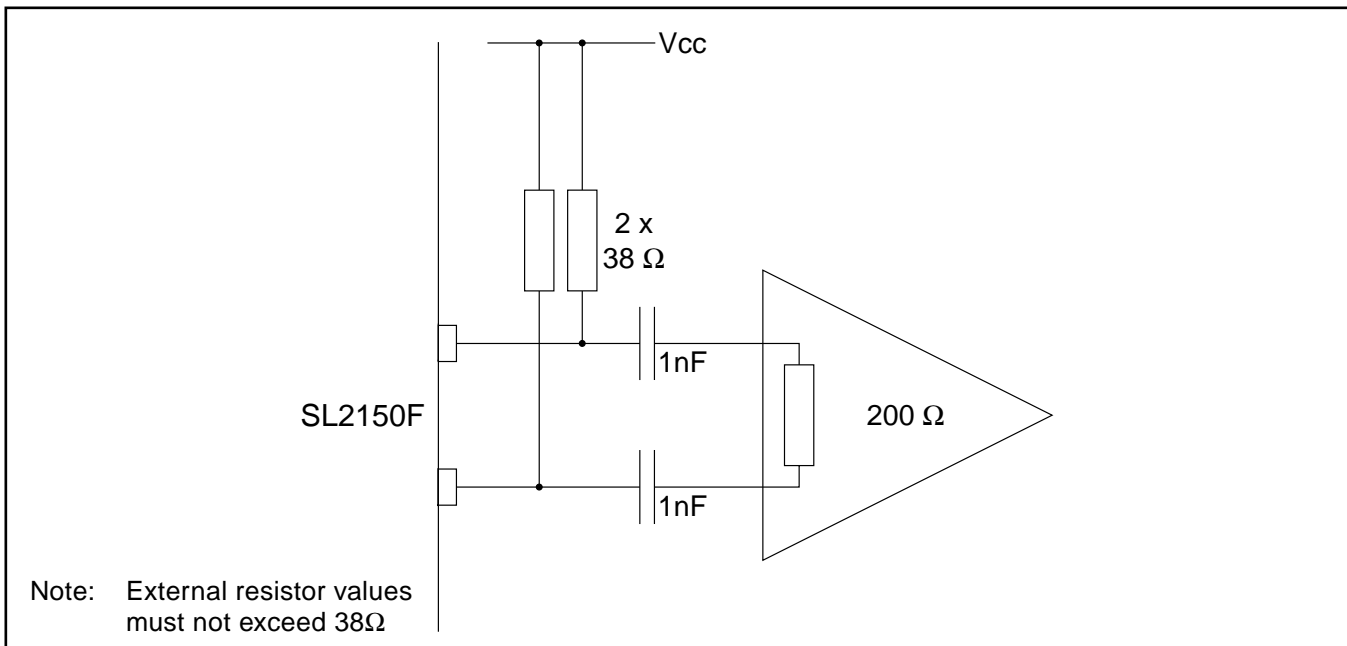

Figure 13b - Example application driving 200Ω load with resistive pull up

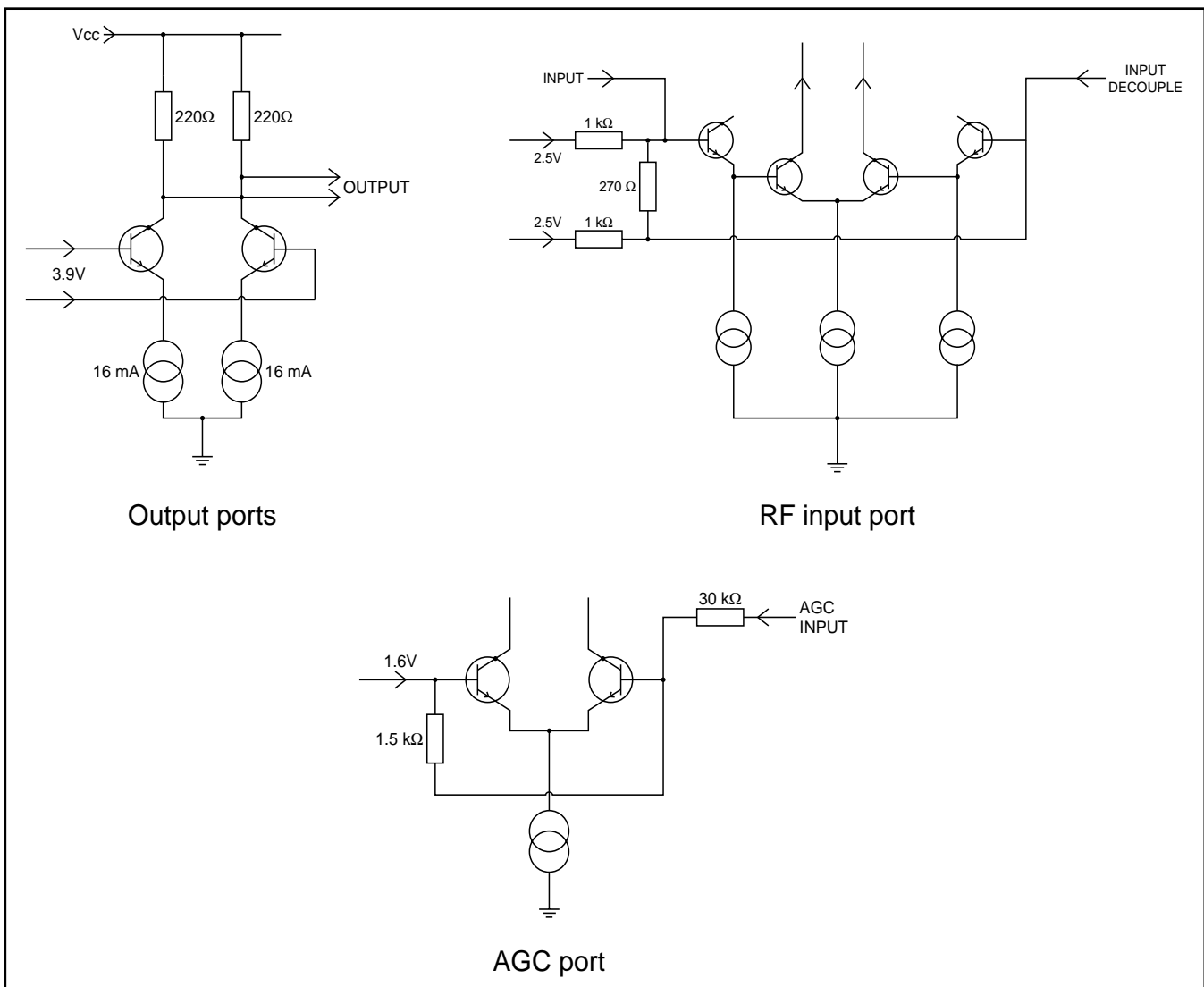

Figure 14 - Port peripheral circuitry

Electrical Characteristics

Test conditions (unless otherwise stated)

Tamb = -40° to 85°C, Vee= 0V, Vcc=5V+-5%

These characteristics are guaranteed by either production test or design. They apply within the specified ambient temperature and supply voltage unless otherwise stated.

Characteristic	pin	min	typ	max	units	Conditions
Supply current			190	228	mA	
Input frequency range		50		860	MHz	
Input impedance	3,4		75		Ω	See figure (4)
Input return loss			8		dB	
Input Noise Figure				8	dB	Tamb=27°C, see figure (5) All loops at maximum conversion gain
Variation in NF with gain adjust				-1	dB/dB	See figure (8)
Gain						Power gain from 75Ω single ended source to differential 75Ω load
maximum		4	5.5	7	dB	Vagcip=3.0V
minimum				-25	dB	Vagcip=0.5V
minimum			-65		dB	Vagcip=Vee
						AGC monotonic from Vee to Vcc
						Refer to 'Functional description' section for information on calculating maximum gain with other load conditions
Input referred IP2		42			dBm	Assuming ideal power match. See note (2) and figure (6)
Input referred IP3		18			dBm	Assuming ideal power match. See note (2) and figure (6)
Input referred IM2				-57	dBc	See note (2) and figure (6)
				-37	dBc	See note (3) and figure (6)
Input referred IM3				-66	dBc	See note (2) and figure (6)
				-46	dBc	See note (3) and figure (6) All gain settings
CSO				-62	dBc	See note (4) and figure (9)
CTB				-64	dBc	See note (4)
CXM				-64	dBc	See note (4)

Characteristic	pin	min	typ	max	units	Conditions
Input P1dB			+9		dBm	All gain settings, with load as in figure (12)
Gain variation within channel			0.25		dB	Channel bandwidth 8 MHz within operating frequency range, all loops, all gain settings
Output impedance	11,12 15,16 20,21 24,25		440		Ω	Differential
Output port DC standing current	11,12 15,16 20,21 24,25			25	mA	Standing current that any external load has to sustain
AGC input leakage current	6,7 8,9	-150		150	μ A	Vagcip = Vee to Vcc, all control inputs
Crosstalk between all loop outputs				-25	dB	All gain settings, measured differential output to differential output, driven ports in phase and monitored ports out of phase, see figure (10)
Crosstalk between all loop outputs and RF input				-30	dB	All gain settings, measured differential output to single ended input, driven ports in phase, see figure (11)

Notes

- (1) All power levels are referred to 75 Ω and 0 dBm = 109 dB μ V
- (2) Any two tones within RF operating range at -15 dBm, from single-ended 75 ohm source into differential 75 Ω load as in figure (12), gain setting between maximum and -15dB backoff.
- (3) Any two tones within RF operating range at -5 dBm, from single-ended 75 ohm source into differential 75 Ω load as in figure (12)
- (4) Load as in figures (12) & (13), max gain, 132 channel matrix, 75 ohm source with all channels at +15 dBmV, assuming power match

Absolute Maximum Ratings

All voltages are referred to Vee at 0V

Characteristic	min	max	units	conditions
Supply voltage	-0.3	6	V	
RF input voltage		8	dBm	Differential
All I/O port DC offsets	-0.3	Vcc+0.3	V	
Storage temperature	-55	150	°C	
Junction temperature		125	°C	Power applied
Package thermal resistance, chip to ambient		35	°C/W	Paddle to be soldered to ground plane
Power consumption at 5.25V		1200	mW	
ESD protection	1.5		kV	Mil-std 883B method 3015 cat1

Evaluation Board

Figures 15 and 16 show schematic and PCB layout for a 4 layer evaluation board.

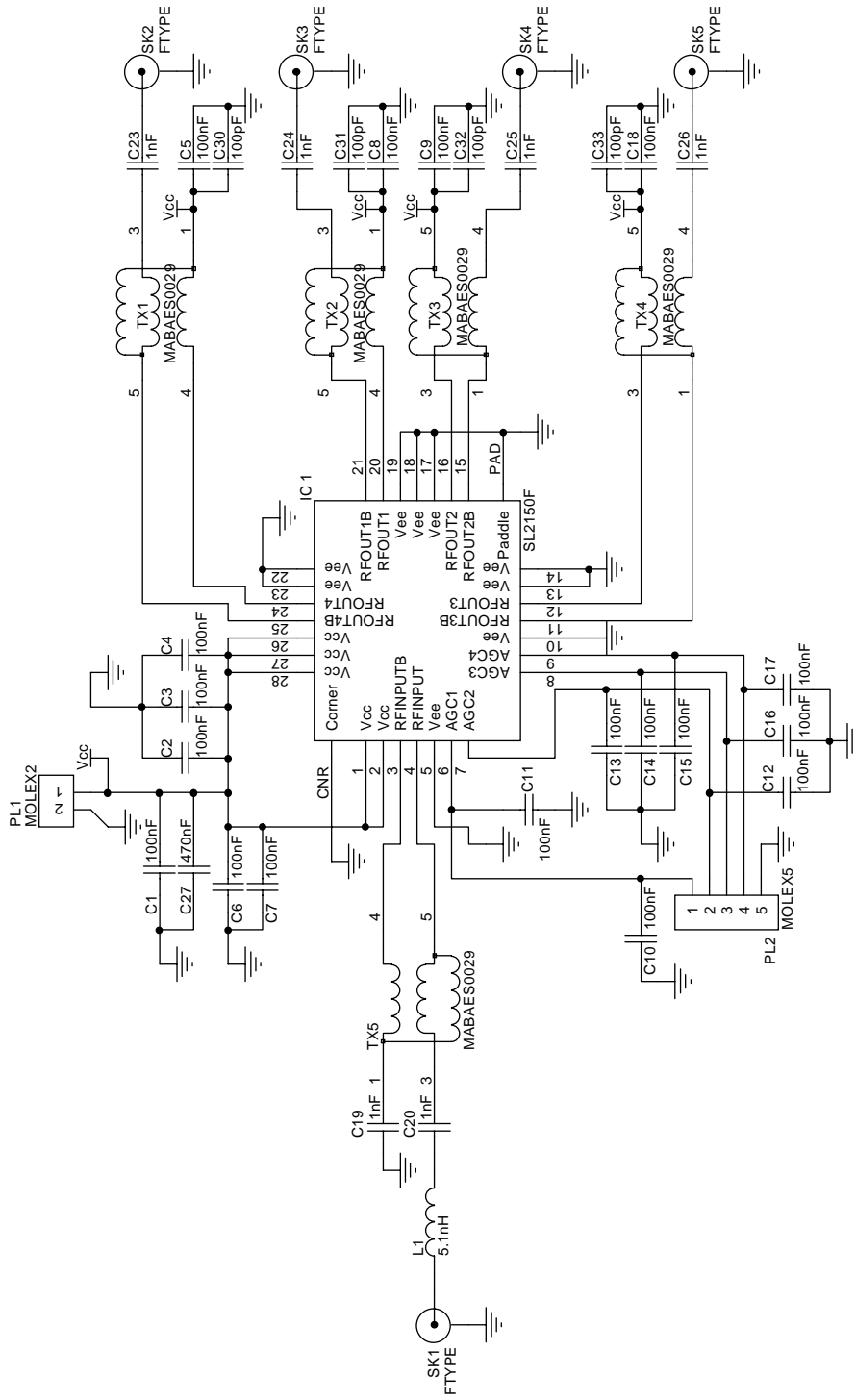

Figure 15 - SL2150F evaluation PCB Schematic

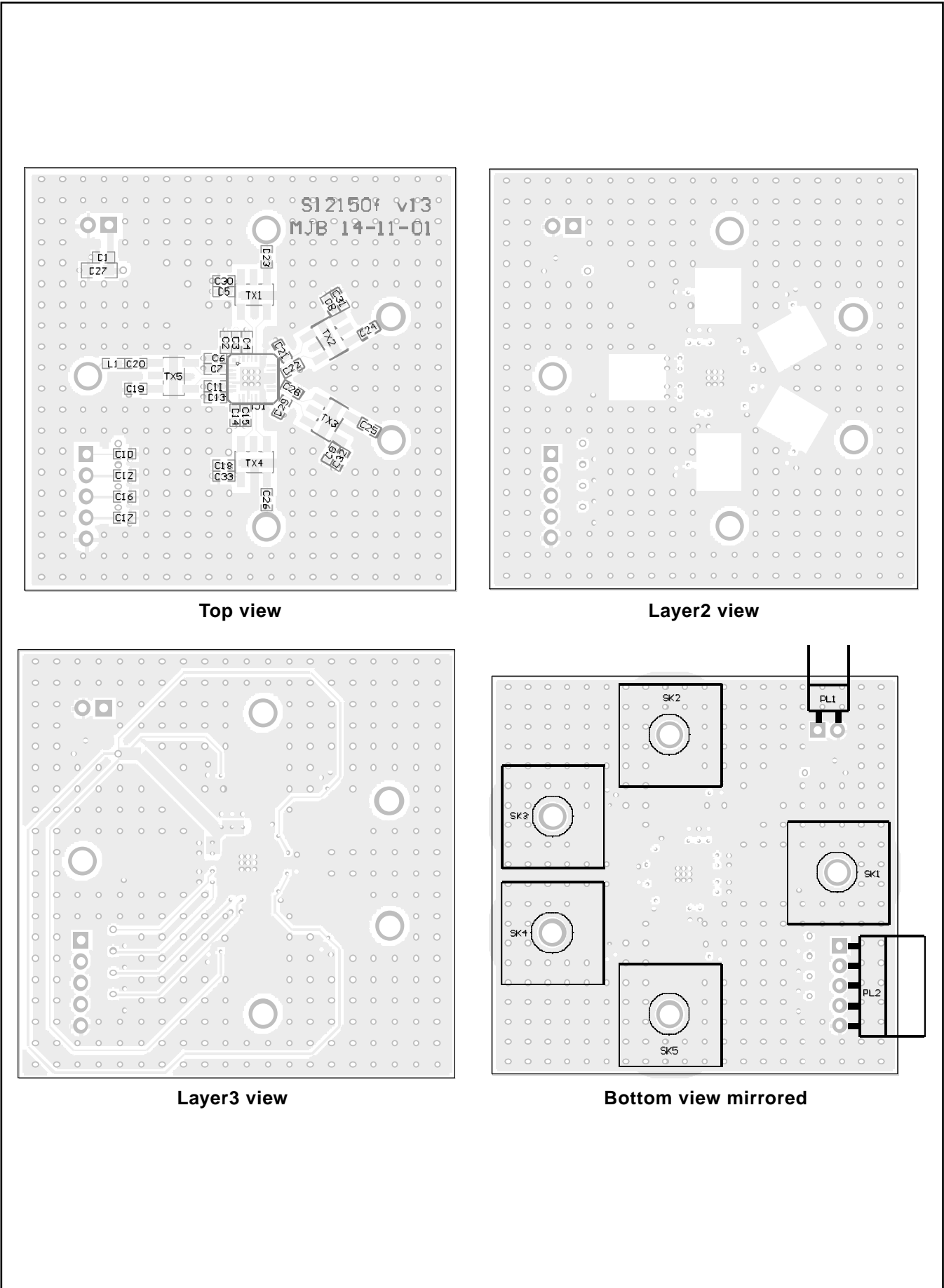
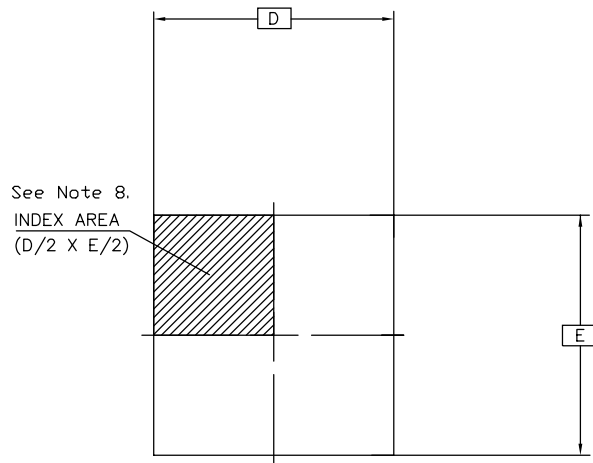
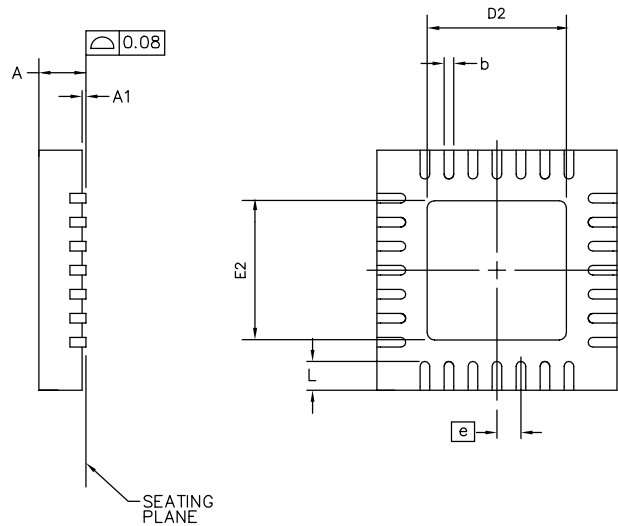

Figure 16 - SL2150F evaluation PCB layout



TOP VIEW



BOTTOM VIEW

SYMBOL	COMMON DIMENSIONS	
	MIN.	MAX.
A	—	1.00
A1	0.00	0.05
b	0.18	0.30
D	5.00 BSC	
D2	3.00	3.25
E	5.00 BSC	
E2	3.00	3.25
N	28	
Nd	7	
Ne	7	
ⓐ	0.50 BSC	
L	0.35	0.75

Conforms to JEDEC MO-220 VHHD-1 iss A

- NOTES:
1. DIMENSIONING & TOLERANCES CONFORM TO ASME Y14.5M. – 1994.
 2. N IS THE NUMBER OF TERMINALS.
Nd & Ne ARE THE NUMBER OF TERMINALS ON EACH D AND E SIDE RESPECTIVELY
 3. DIMENSION b APPLIES TO PLATED TERMINAL AND IS MEASURED BETWEEN 0.25 AND 0.30mm FROM TERMINAL.
 4. ALL DIMENSIONS ARE IN MILLIMETERS.
 5. LEAD COUNT IS 28 .
 6. PACKAGE WARPAGE MAX 0.08mm.
 7. NOT TO SCALE.
 8. TERMINAL #1 IDENTIFIER MUST BE LOCATED WITHIN THE ZONE INDICATED AND MAY BE EITHER A MOULD OR MARKED FEATURE.

ORIGINATING SITE: Swindon

Title: Package Outline For
28 Lead MLP (5 x 5 x 0.9)mm(LH)

Drawing Number

GPDO0747

ISSUE	1				
ACN	209757				
DATE	26OCT00				
APPRD.					



<http://www.zarlink.com>

World Headquarters - Canada

Tel: +1 (613) 592 0200

Fax: +1 (613) 592 1010

North America - West Coast

Tel: (858) 675-3400

Fax: (858) 675-3450

North America - East Coast

Tel: (978) 322-4800

Fax: (978) 322-4888

Asia/Pacific

Tel: +65 333 6193

Fax: +65 333 6192

**Europe, Middle East,
and Africa (EMEA)**

Tel: +44 (0) 1793 518528

Fax: +44 (0) 1793 518581

Information relating to products and services furnished herein by Zarlink Semiconductor Inc. trading as Zarlink Semiconductor or its subsidiaries (collectively "Zarlink") is believed to be reliable. However, Zarlink assumes no liability for errors that may appear in this publication, or for liability otherwise arising from the application or use of any such information, product or service or for any infringement of patents or other intellectual property rights owned by third parties which may result from such application or use. Neither the supply of such information or purchase of product or service conveys any license, either express or implied, under patents or other intellectual property rights owned by Zarlink or licensed from third parties by Zarlink, whatsoever. Purchasers of products are also hereby notified that the use of product in certain ways or in combination with Zarlink, or non-Zarlink furnished goods or services may infringe patents or other intellectual property rights owned by Zarlink.

This publication is issued to provide information only and (unless agreed by Zarlink in writing) may not be used, applied or reproduced for any purpose nor form part of any order or contract nor to be regarded as a representation relating to the products or services concerned. The products, their specifications, services and other information appearing in this publication are subject to change by Zarlink without notice. No warranty or guarantee express or implied is made regarding the capability, performance or suitability of any product or service. Information concerning possible methods of use is provided as a guide only and does not constitute any guarantee that such methods of use will be satisfactory in a specific piece of equipment. It is the user's responsibility to fully determine the performance and suitability of any equipment using such information and to ensure that any publication or data used is up to date and has not been superseded. Manufacturing does not necessarily include testing of all functions or parameters. These products are not suitable for use in any medical products whose failure to perform may result in significant injury or death to the user. All products and materials are sold and services provided subject to Zarlink Semiconductor's conditions of sale which are available on request.

Purchase of Zarlink's I²C components conveys a licence under the Philips I²C Patent rights to use these components in an I²C System, provided that the system conforms to the I²C Standard Specification as defined by Philips

Zarlink and the Zarlink Semiconductor logo are trademarks of Zarlink Semiconductor Inc.
Copyright 2001, Zarlink Semiconductor Inc. All rights reserved.

TECHNICAL DOCUMENTATION - NOT FOR RESALE