

### 1 Overview

#### 1.1 Features

##### Stereo-Soundprocessing

- Three stereo AF inputs, one of the inputs is equipped with floating ground.
- Input level control for individual level setting of the several AF sources in addition with a clipping detector.
- Volume control with software controlled switchable loudness function. Frequency response fixed by external components.
- Bass- and treble control with clipping detector.
- Four independent settable output attenuators for balance/fader function.
- Fan-out of the AF outputs software controlled.
- AF outputs switchable for driving bridge power amplifiers.
- I<sup>2</sup>C Bus controlled immediately, or zero cross detector dependent mute, or immediately mute via extra pin.

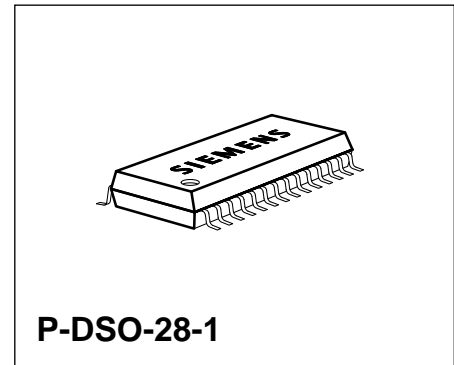

##### Control Part

- I<sup>2</sup>C Bus interface
- Control of sound processing
- Read out of the clipping detector status.

Type	Ordering Code	Package
TDA 4350X	Q67000-A5060	P-DSO-28-1

#### 1.2 Application

The TDA 4350X is a single-chip audio-soundsystem. The circuit can be partitioned into two functional blocks: stereo-soundprocessing and control part.

## 1.3 Pin Configuration (top view)

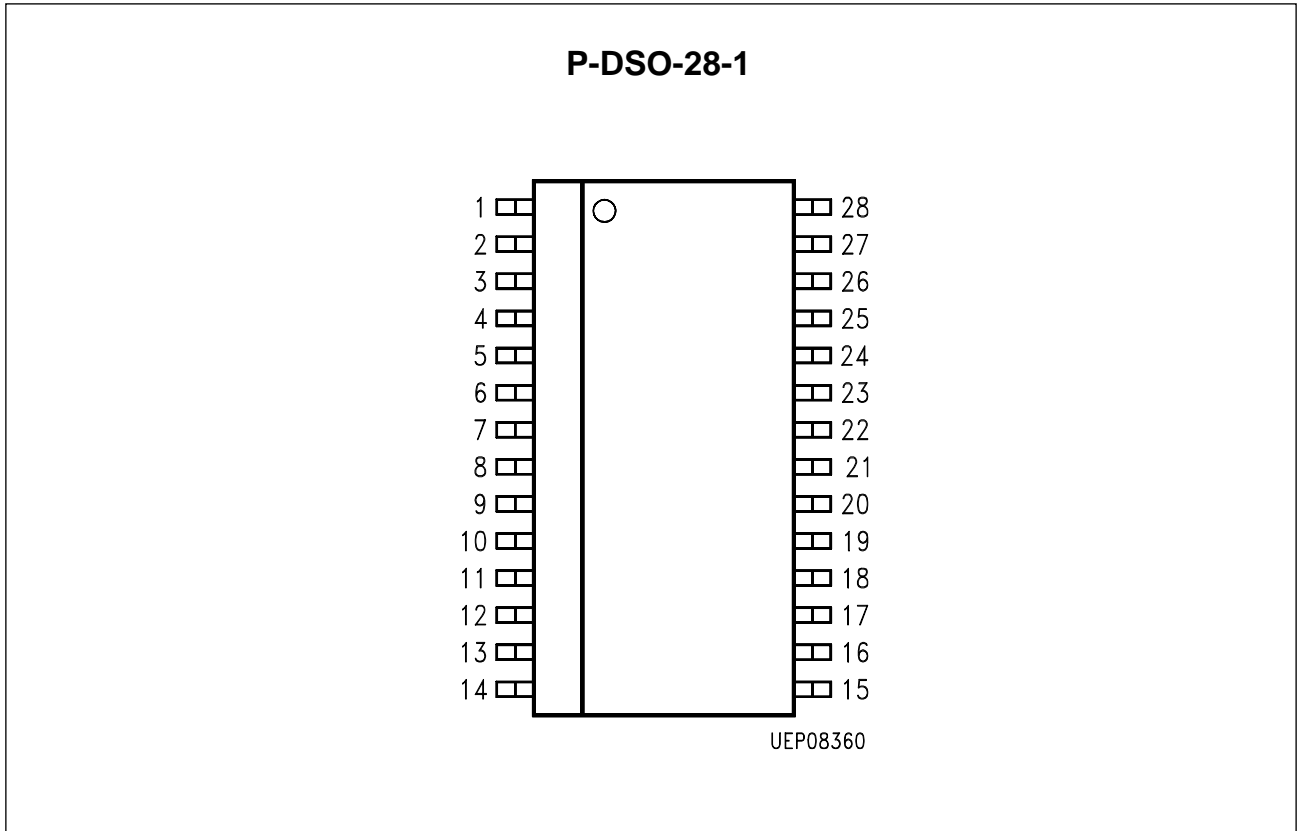

**Figure 1**

## 1.4 Pin Definitions and Functions

Pin No.	Function
1	CD input right
2	Input 2 right
3	Input 3 right
4	Loudness output right
5	Loudness input right
6	Digital ground
7	Mute
8	I <sup>2</sup> C Bus SCL
9	I <sup>2</sup> C Bus SDA
10	+ V <sub>S</sub> supply voltage
11	Corner frequency treble left
12	Corner frequency treble right
13	AF output right front
14	AF output right rear
15	AF output left rear
16	AF output left front
17	RC network bass right
18	RC network bass right
19	RC network bass left
20	RC network bass left
21	Analog ground
22	Bias for AF operation point
23	Loudness output left
24	Loudness input left
25	Input 3 left
26	Input 2 left
27	CD ground
28	CD input left

1.5 Functional Block Diagram

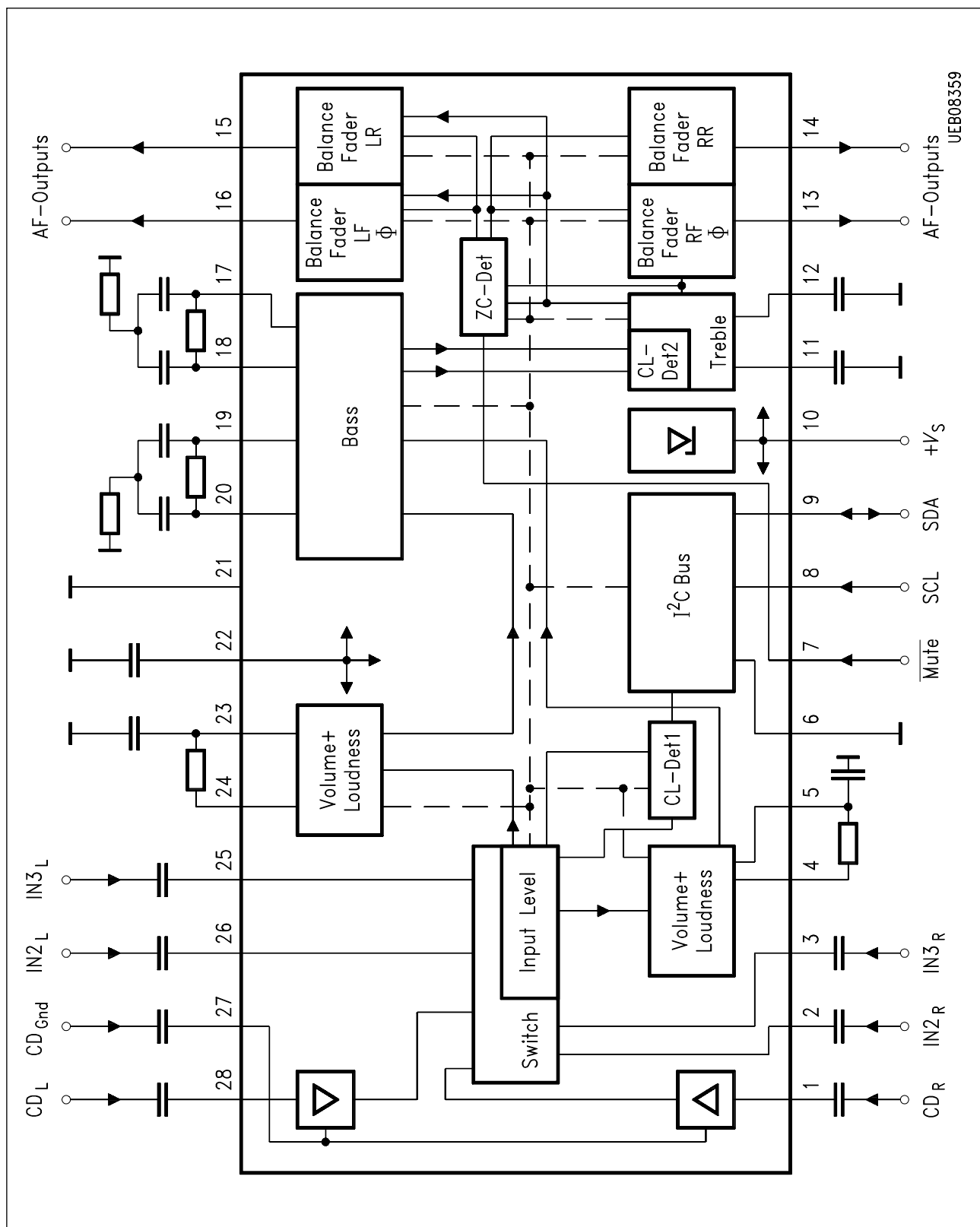
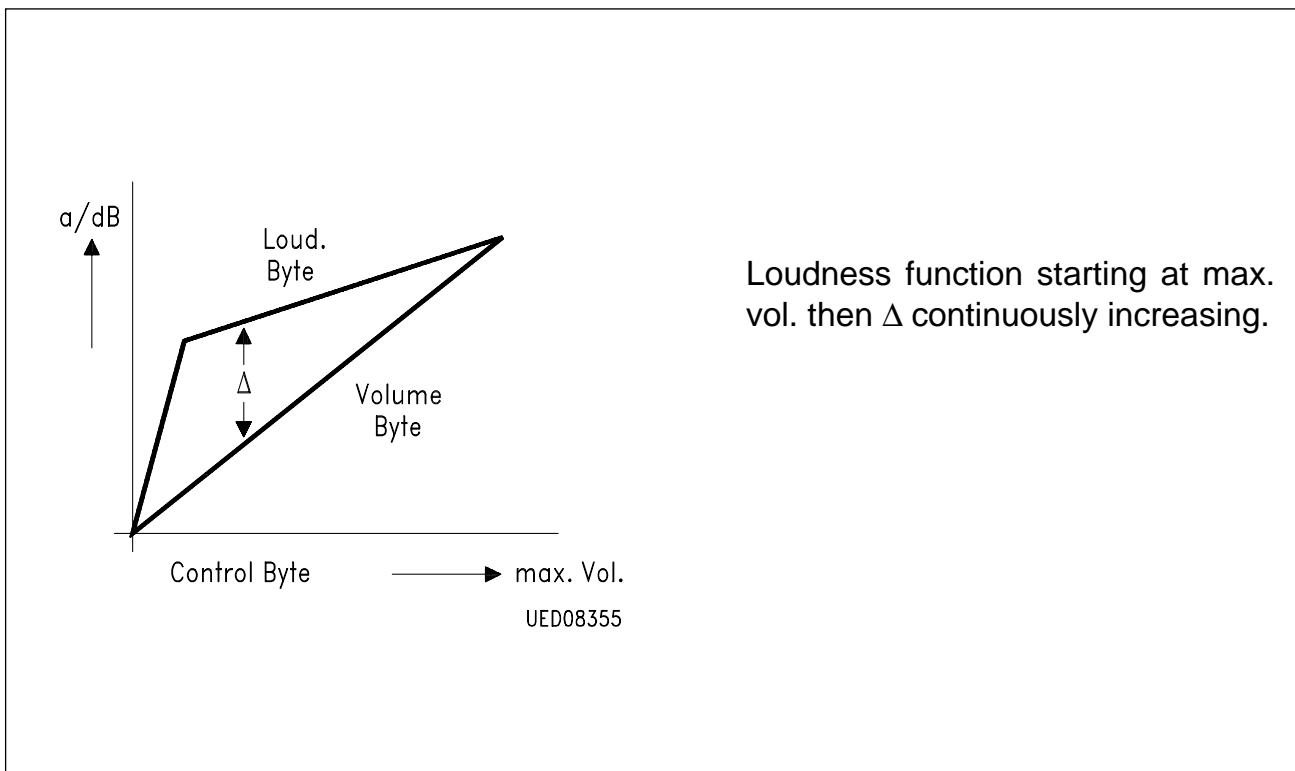

Figure 2  
Block Diagram

## 2 Circuit Description

### 2.1 Signalprocessing

1. The selection of the AF inputs happens in the input switch. There are three stereo-inputs available. One of the input pairs is equipped with a separate floating ground connection especially provided for external signal sources. Crosstalk to this input is suppressed by common mode rejection. An input level control circuitry behind input switch realizes the adaption of different signal source levels. The circuit offers a control range from 0 dB to + 25 dB with a stepwidth of 2.5 dB. An I<sup>2</sup>C Bus controlled first clipping detector allows a software controlled level adaption.
2. Next stage in signal path is volume control, with common setting for both channels, a control range of 0 dB to – 78.75 dB and a stepwidth of 1.25 dB. In this stage a loudness function is realized. A loudness control circuit, in fact a second volume control circuit with identical structure, is to be set to a higher level as volume control. The resulting level difference fixes the maximum amplitude response of the loudness function. The frequency response, only bass boost or combined bass and treble boost is fixed by external components. Because the volume and loudness control are strictly independent of each other, the frequency response and threshold of the loudness function is programmable via software. A switch bit allows to enable the loudness function easily. Some possible loudness setups:



**Figure 3**

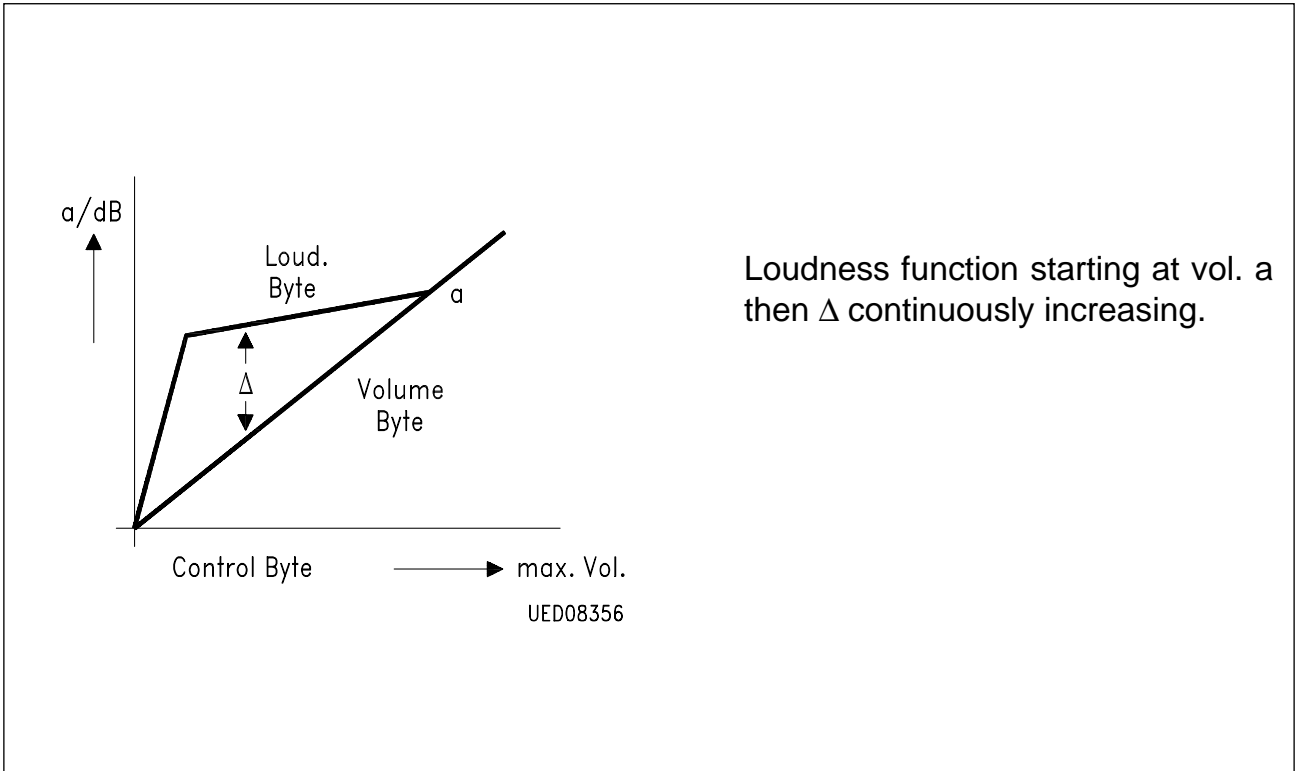

Figure 4

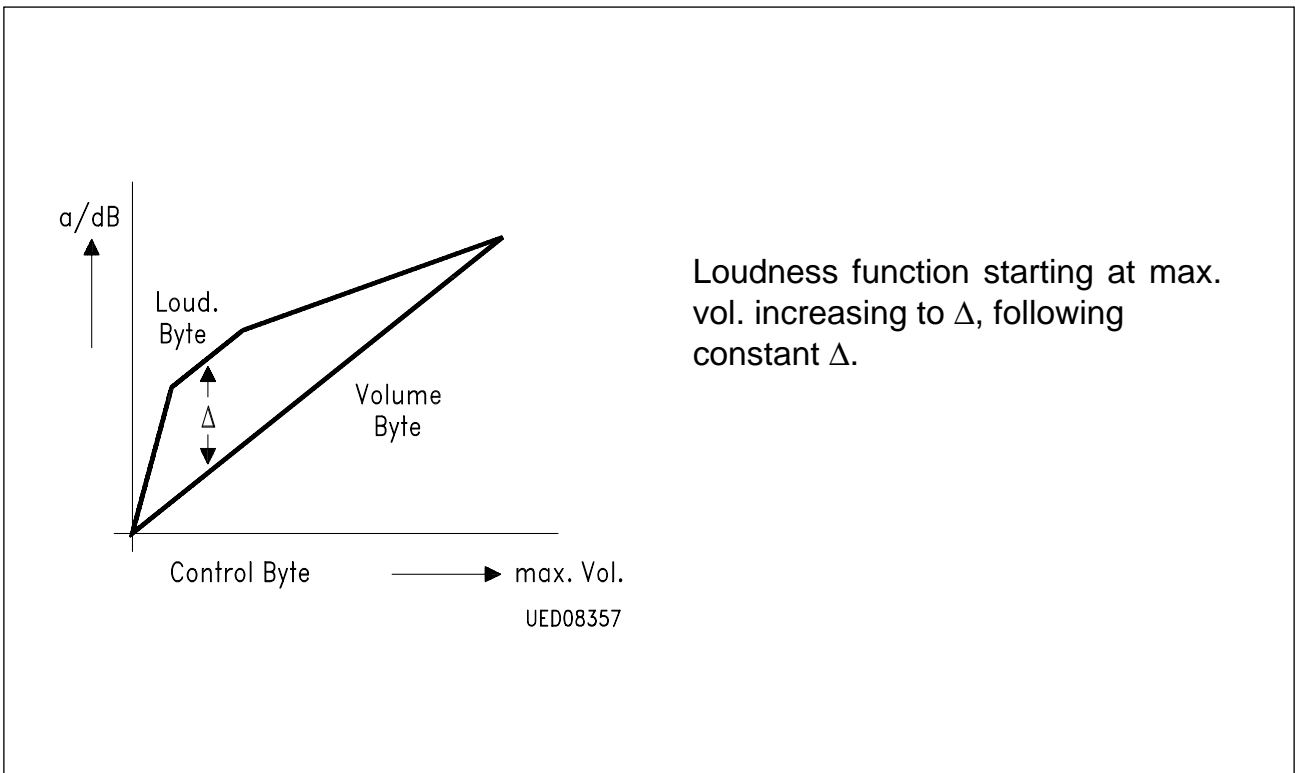
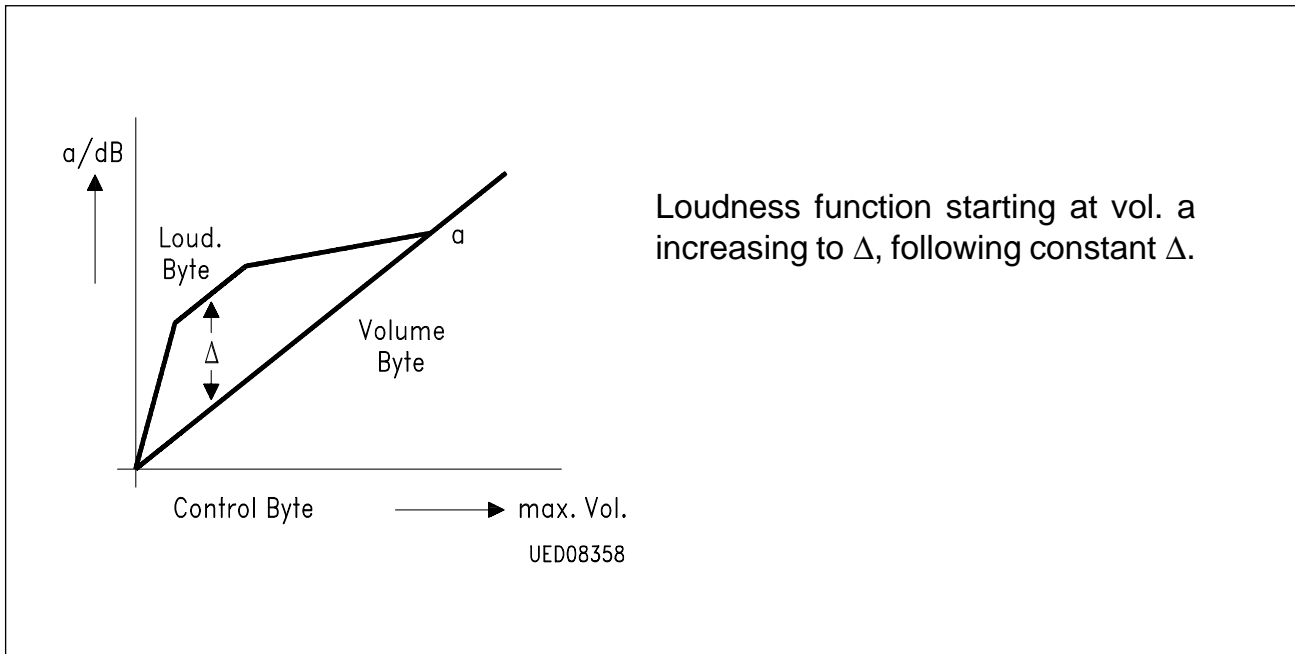

Figure 5



**Figure 6**

3. In the following signalpath there is tone control, consisting of bass and treble control. Bass control offers a control range of + 16 dB to – 14 dB with a stepwidth of 2 dB. Frequency characteristic, 1st order or 2nd order (resonance type) is fixed by external components. Treble control also offers a control range of + 16 dB to – 14 dB with a stepwidth of 2 dB. The treble control corner frequency is determined by an external capacitor.

A second clipping detector allows to detect clipping in tone control part.

4. Last stages in signal path are four strictly independent controllable output attenuators to realize balance and fader function. Each unit offers a control range of 0 dB to – 38.75 dB in steps of 1.25 dB. The AF outputs are of a class A-type to avoid distortion via software, the output fan-out can be increased to drive loads up to > 1.5 k $\Omega$ .

One output of each stereo channel can be inverted software controlled, to drive easily bridge power amplifiers.

5. Mute control may be either done via the volume control setting, or directly for all outputs by setting the IM (immediately mute) bit via I<sup>2</sup>C Bus. The second bus controlled mute mode is mute after signal zero crossing (ZCM). Two zero cross detectors are built-in, therefore this mute control works independent for left and right channel. Signal off- and on-switching is performed under zero cross detector control. The ZCM status can be read out via I<sup>2</sup>C Bus (ZCS). After activating ZCM, the ZCS (zero crossing status) bit is set to '1', when all outputs are muted after zero crossing. After deactivating ZCM, the ZCS bit is set to '0' when all outputs are switched on after zero crossing. The IM mute overwrites ZCM mute. Third mute control is hardware mute via a mute pin. If the mute pin is switched to ground all outputs are muted immediately. Hardware mute overwrites all other mute modes.

## 2.2 Controlpart

All functions are controlled via an I<sup>2</sup>C Bus interface. All data are stored into a latch circuit. The telegram structure is built as follows:

Startcondition – chipaddress – any number of databytes – stopcondition.

For the databytes the following conditions must be fulfilled:

Before transmitting a databyte a subaddress byte must first be placed in the data telegram.

### 2.2.1 Chipaddress

MSB							LSB
1	0	0	0	0	1	1	R/W
R/W = '0' → Read				R/W = '1' → Write			

### 2.2.2 Subaddress Bytes

	MSB						LSB	
Switchbyte	0	0	0	0	0	0	0	0
Inputlevel	0	0	0	0	0	0	0	1
Volume	0	0	0	0	0	0	1	0
Loudness	0	0	0	0	0	0	1	1
Bass/Treble	0	0	0	0	0	1	0	0
Out rear left	0	0	0	0	0	1	0	1
Out front left	0	0	0	0	0	1	1	0
Out rear right	0	0	0	0	0	1	1	1
Out front right	0	0	0	0	1	0	0	0



## 2.2.3 Control Bytes

### a) Switch Control Byte

MSB							LSB
ZCM	IM	Fan	Ph	IN-3	IN-2	IN-CD	X

IN-CD = '0'                      CD input OFF; power ON

IN-CD = '1'                      CD input ON

IN-2 = '0'                        Input 2 OFF; power ON

IN-2 = '1'                        Input 2 ON

IN-3 = '0'                        Input 3 OFF; power ON

IN-3 = '1'                        Input 3 ON

If no input is selected, mute function is active.

If no protection against multiple selection implemented!

Ph = '0'                          Bridgepower amplifier operation ON; power ON

Ph = '1'                          Normal operation

Fan = '0'                         Normal operation; power ON

Fan = '1'                         Increased Fan out ON

IM = '0'                         Normal operation; power ON

IM = '1'                         Immediate mute for all AF outputs

ZCM = '0'                        Normal operation; power ON

ZCM = '1'                        Mute after signal zero crossing

IM overwrites ZCM, hardware mute overwrites all other mute modes.

### b) Input Level Control Byte

	MSB				LSB				
Min. gain	X	X	X	X	0	0	0	0	
Min. gain + 1	X	X	X	X	0	0	0	1	power ON
Max. gain - 1	X	X	X	X	1	0	0	1	
Max. gain	X	X	X	X	1	0	1	0	
	to								
Max. gain	X	X	X	X	1	1	1	1	

### c) Volume Level Control Byte

	MSB						LSB		
Min. gain	X	0	0	0	0	0	0	0	power ON
Min. gain + 1	X	0	0	0	0	0	0	1	
Max. gain – 1	X	0	1	1	1	1	1	0	
Max. gain	X	0	1	1	1	1	1	1	

### d) Loudness Control Byte

	MSB						LSB		
Min. gain	X	Ld	0	0	0	0	0	0	power ON
Min. gain + 1	X	Ld	0	0	0	0	0	1	
Max. gain – 1	X	Ld	1	1	1	1	1	0	
Max. gain	X	Ld	1	1	1	1	1	1	

Ld = '0'      Loudness OFF; power ON  
 (loudness attenuator has the same setting  
 as volume attenuator)

Ld = '1'      Loudness ON

### e) Treble/Bass Control Byte

	MSB				LSB			
linear	1	0	0	0	1	0	0	0
max. treble, lin. bass	0	0	0	0	1	0	0	0
min. treble, lin. bass	1	1	1	1	1	0	0	0
lin. treble, max. bass	1	0	0	0	0	0	0	0
lin. treble, min. bass	1	0	0	0	1	1	1	1
max. treble, max. bass	0	0	0	0	0	0	0	0
min. treble, min. bass	1	1	1	1	1	1	1	1
power ON	0	0	0	0	0	0	0	1
	treble				bass			

### f) Output Control Bytes

	MSB				LSB			
Min. gain	X	X	X	X	0	0	0	0
Min. gain + 1	X	X	X	X	0	0	0	1
Max. gain - 1	X	X	X	X	1	1	1	0
Max. gain	X	X	X	X	1	1	1	1

power ON

## 2.2.4 Talkmode

MSB				LSB			
CI1	CI2	ZCS	X	X	X	X	X

CI1 = '0'                      Normal operation  
 CI1 = '1'                      Input level control output at clipping level  
 CL 2 = '0'                      Normal operation  
 CL2 = '1'                      Tone control output at clipping level  
 ZCS = '0'                      All AF outputs are ON after ZCS set to '0'  
 ZCS = '1'                      All AF outputs are muted after ZCM set to '1'

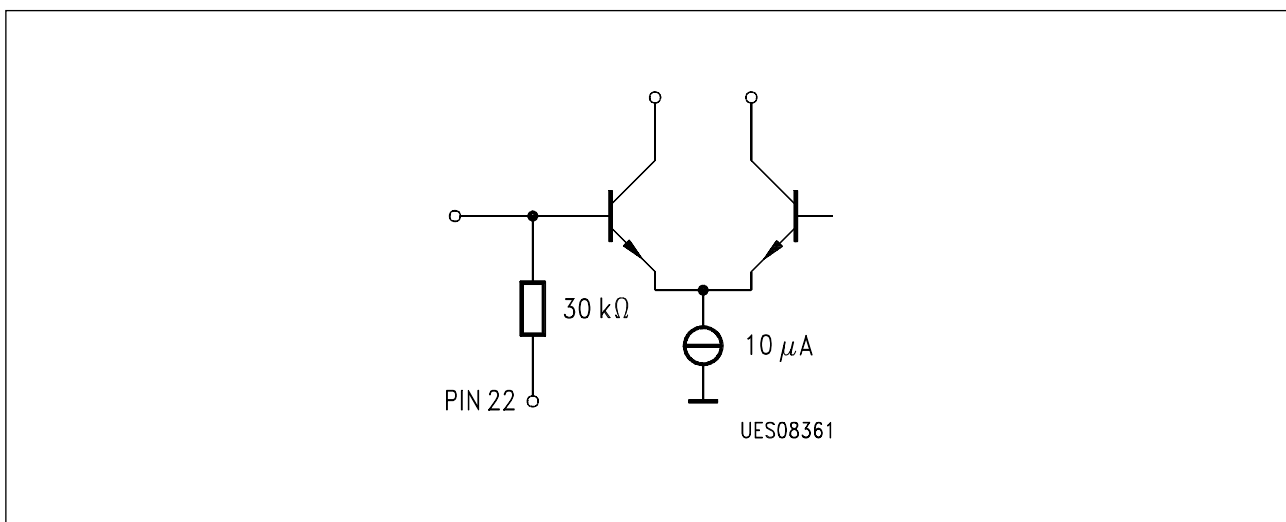

**Figure 7**  
**AF Inputs Pin 1/2/3/25/26/27/28**

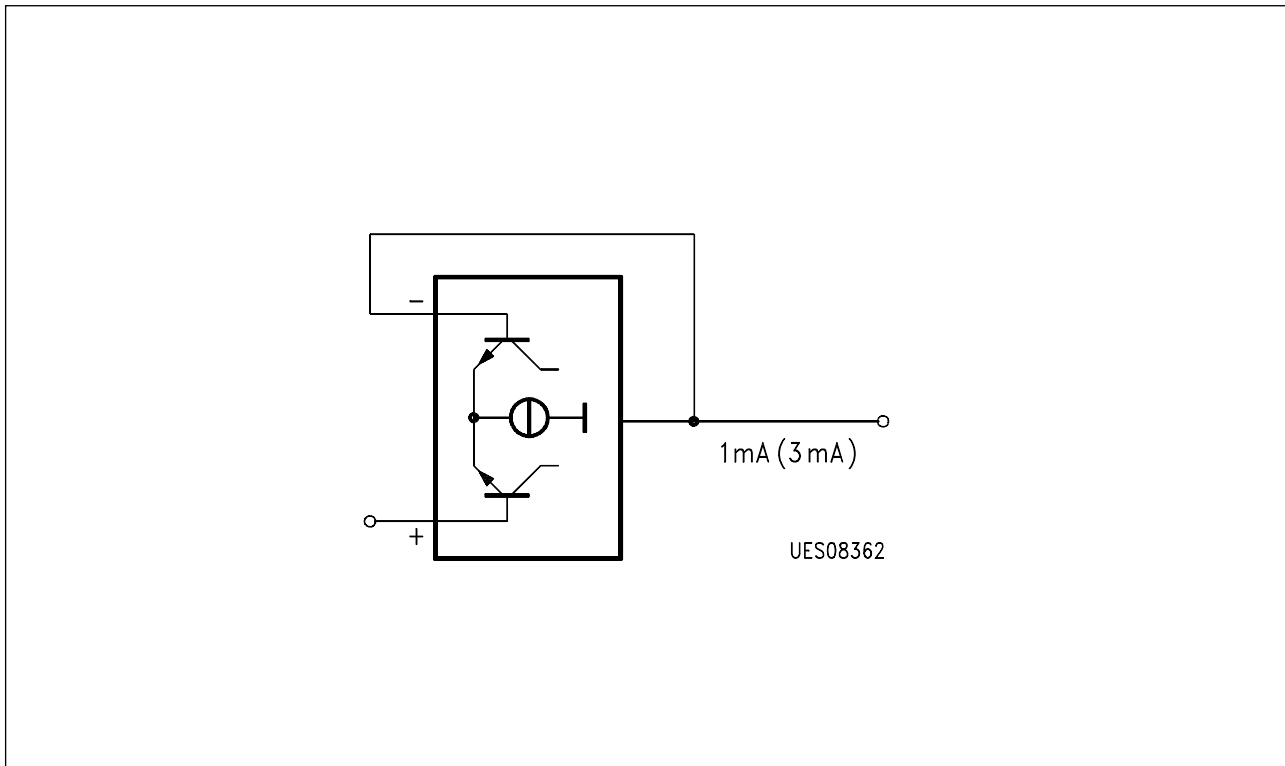

**Figure 8**  
**AF Outputs Pin 13/14/15/16**

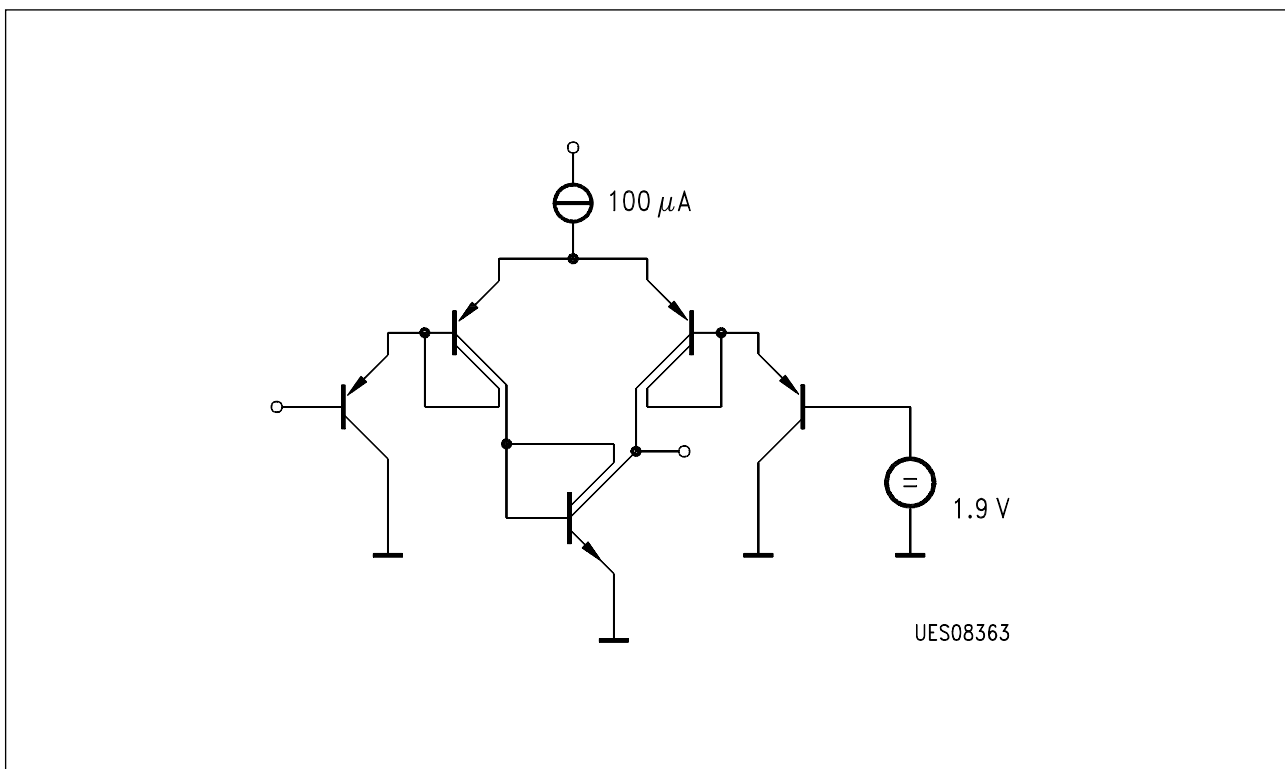

**Figure 9**  
**Mute Pin 7, I<sup>2</sup>C Bus SCL Pin 8**

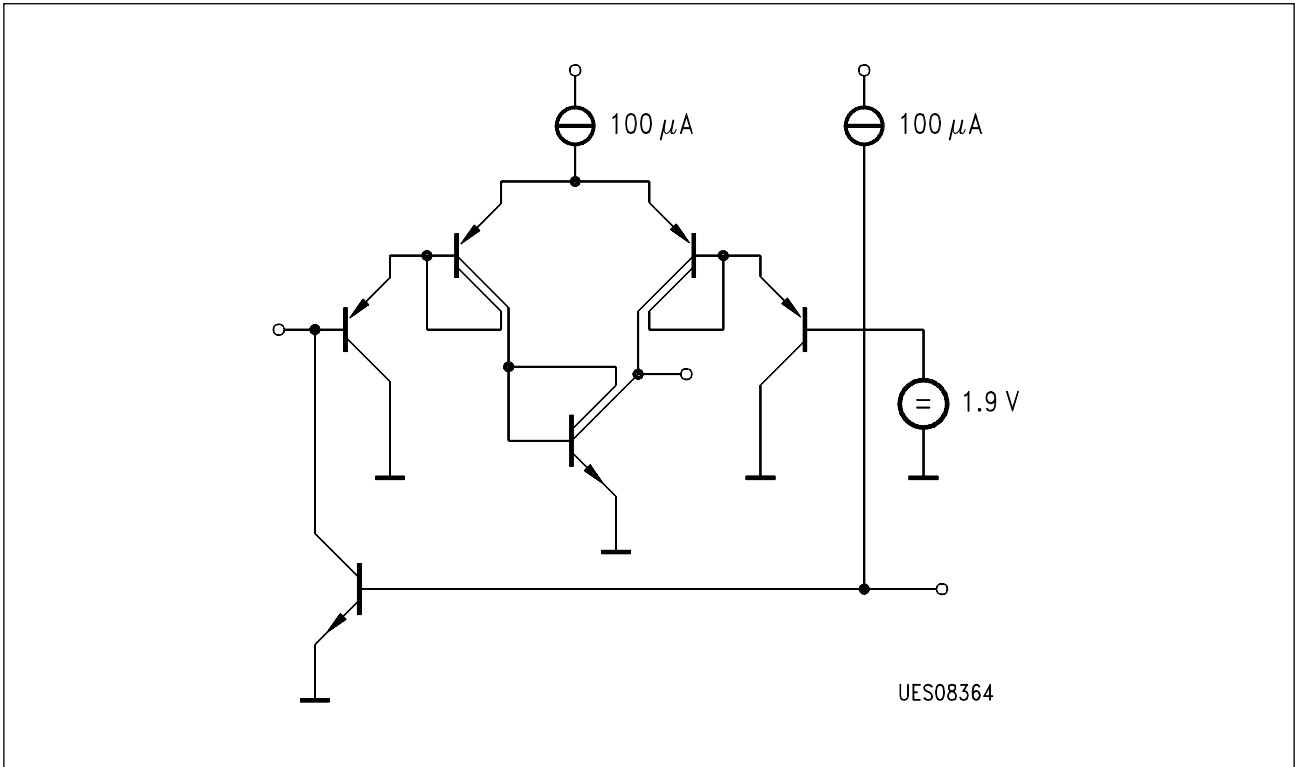

**Figure 10**  
I<sup>2</sup>C Bus SDA Pin 9

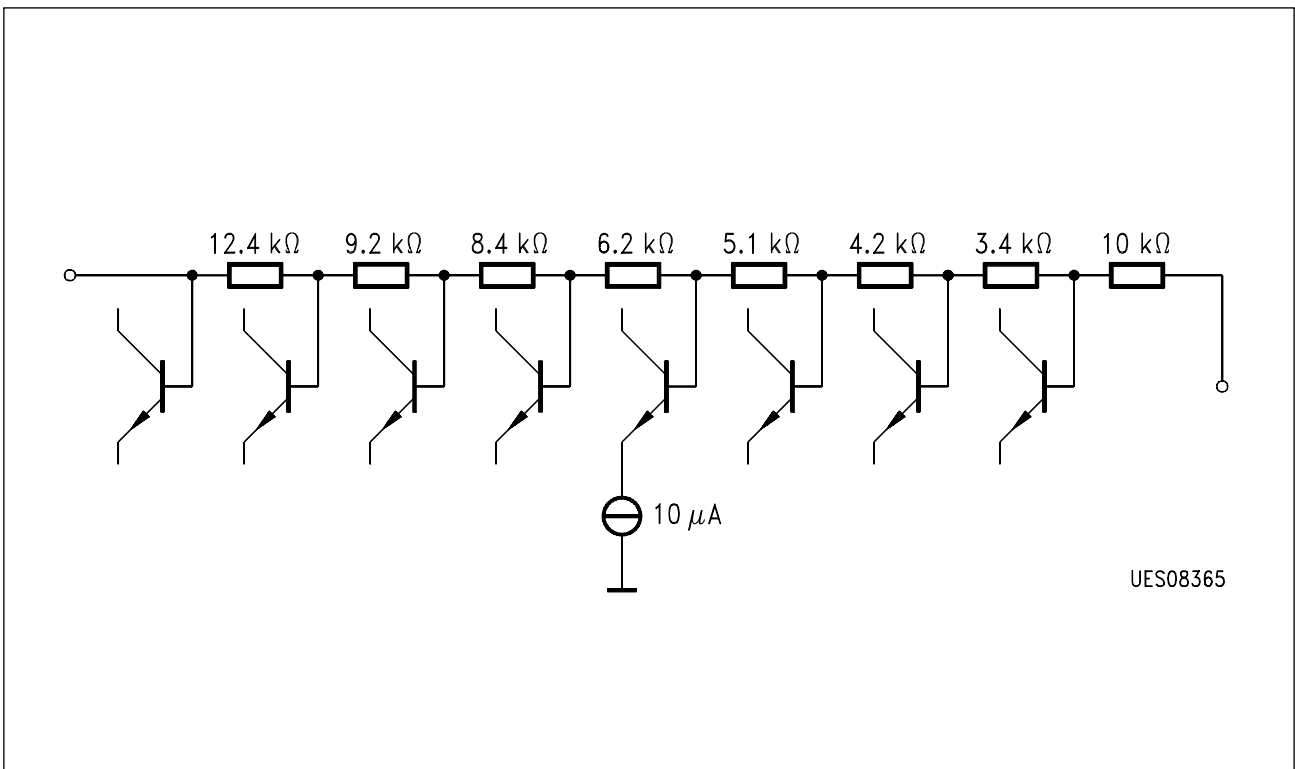

**Figure 11**  
Corner Frequency Treble Pin 11/12

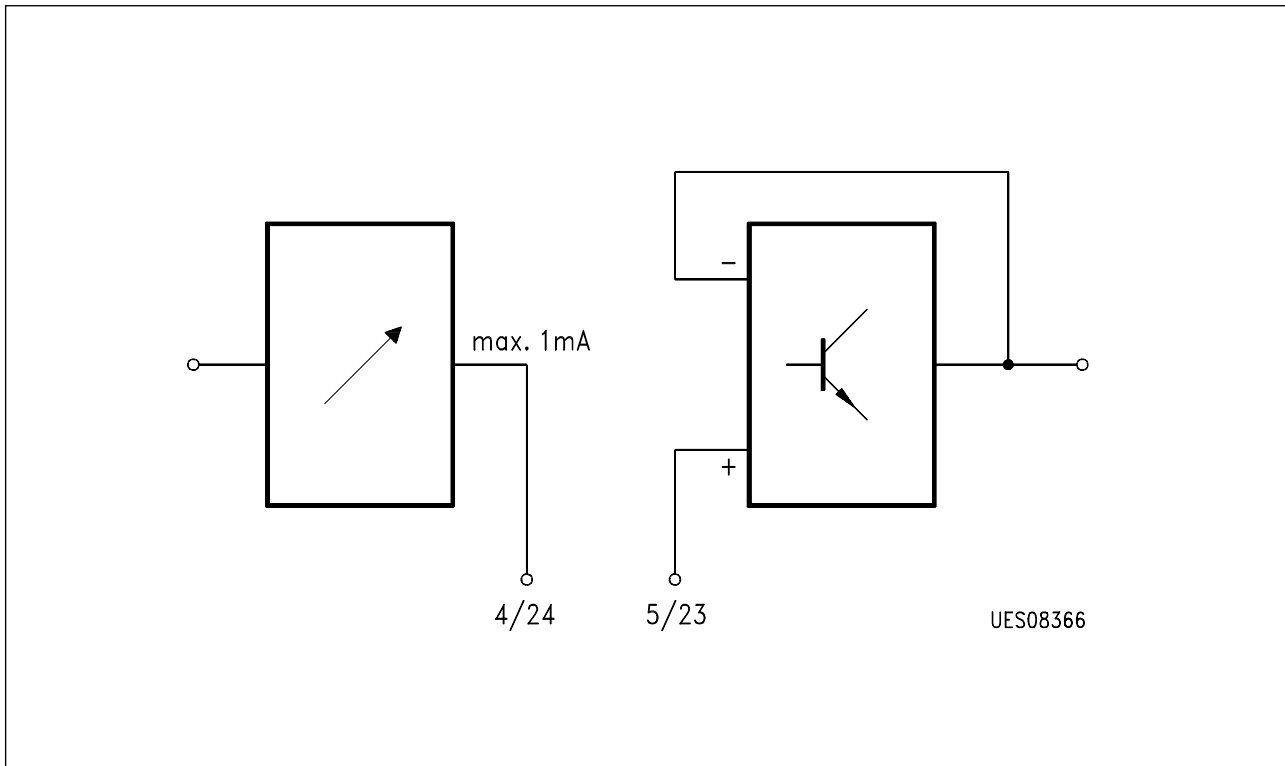

**Figure 12**  
**Loudness Pin 4/5/23/24**

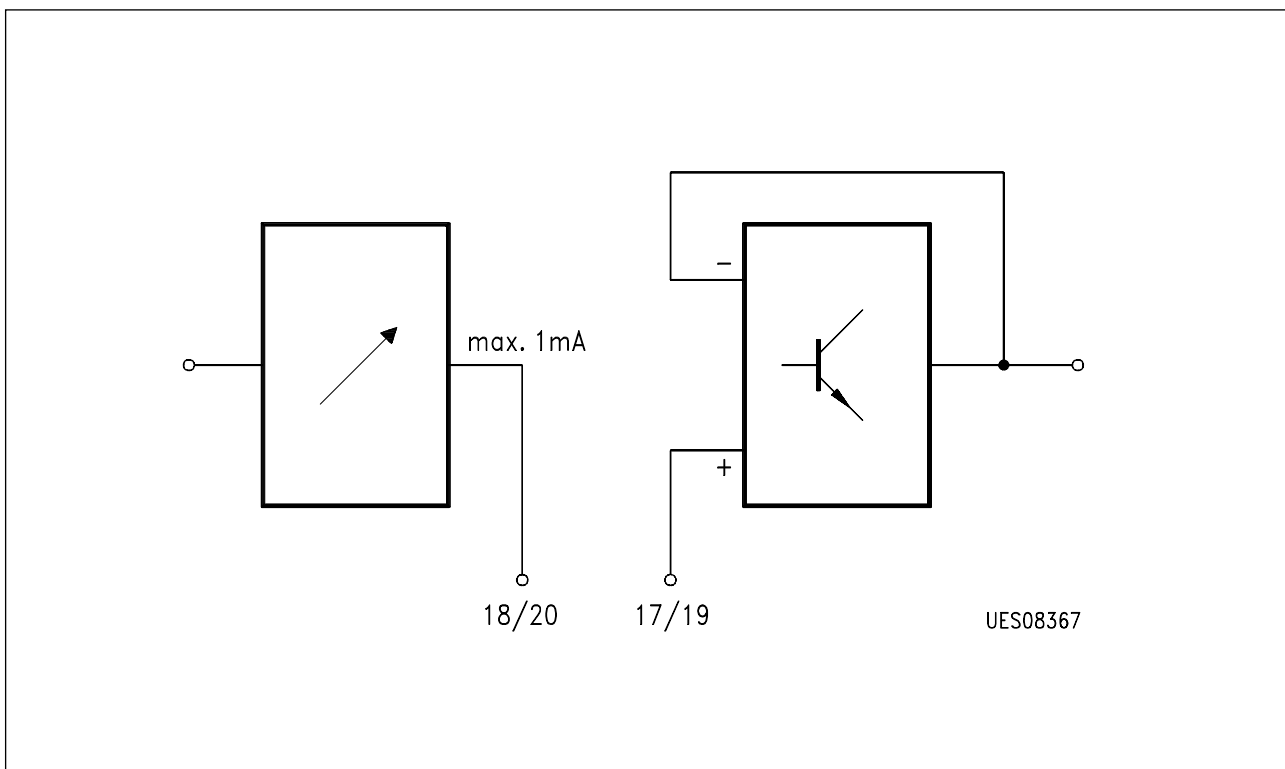

**Figure 13**  
**RC Network Bass Pin 17/18/19/20**

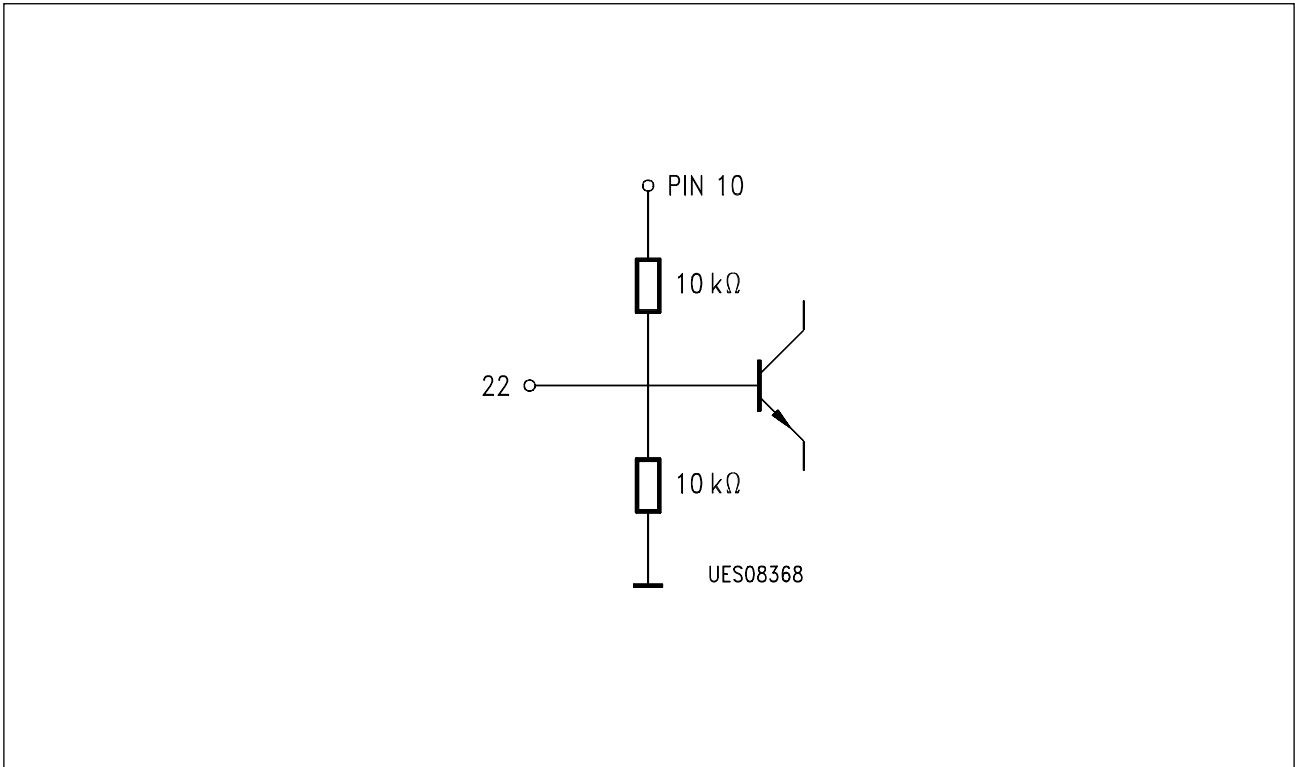

**Figure 14**  
**Bias for AF Operation Point Pin 22**



## 3 Electrical Characteristics

### 3.1 Absolute Maximum Ratings

$T_A = -40\text{ °C to }85\text{ °C}$

Parameter	Symbol	Limit Values		Unit	Remarks
		min.	max.		
Supply voltage	$V_{10}$	0	14	V	
Max. DC voltage	$V_1$	0	$V_{10}$	V	
Max. DC voltage	$V_2$	0	$V_{10}$	V	
Max. DC voltage	$V_3$	0	$V_{10}$	V	
Max. DC voltage	$V_5$	0	$V_{10}$	V	
Max. DC voltage	$V_7$	0	$V_{10}$	V	
Max. DC voltage	$V_8$	0	$V_{10}$	V	
Max. DC voltage	$V_9$	0	$V_{10}$	V	
Max. DC voltage	$V_{11}$	0	$V_{10}$	V	
Max. DC voltage	$V_{12}$	0	$V_{10}$	V	
Max. DC voltage	$V_{17}$	0	$V_{10}$	V	
Max. DC voltage	$V_{19}$	0	$V_{10}$	V	
Max. DC voltage	$V_{22}$	0	$V_{10}$	V	
Max. DC voltage	$V_{23}$	0	$V_{10}$	V	
Max. DC voltage	$V_{25}$	0	$V_{10}$	V	
Max. DC voltage	$V_{26}$	0	$V_{10}$	V	
Max. DC voltage	$V_{27}$	0	$V_{10}$	V	
Max. DC voltage	$V_{28}$	0	$V_{10}$	V	
Max. DC current	$I_4$	0	2	mA	
Max. DC current	$I_{13}$	0	5	mA	
Max. DC current	$I_{14}$	0	5	mA	
Max. DC current	$I_{15}$	0	5	mA	
Max. DC current	$I_{16}$	0	5	mA	
Max. DC current	$I_{18}$	0	2	mA	
Max. DC current	$I_{20}$	0	2	mA	
Max. DC current	$I_{24}$	0	2	mA	

**3.1 Absolute Maximum Ratings (cont'd)**

$T_A = -40\text{ °C to }85\text{ °C}$

Parameter	Symbol	Limit Values		Unit	Remarks
		min.	max.		
Junction temperature	$T_j$		150	°C	
Storage temperature	$T_g$		125	°C	
Thermal resistance	$R_{thSA}$		76	K/W	
ESD voltage, HBM	$V_{ESD1}$	- 4	4	kV	1.5 kΩ, 100 pF
ESD voltage, AF outputs	$V_{ESD2}$	- 6	6	kV	1.5 kΩ, 100 pF

*Note: Maximum ratings are absolute ratings; exceeding only one of these values may cause irreversible damage to the integrated circuit.*

**3.2 Operational Range**

Parameter	Symbol	Limit Values		Unit
		min.	max.	
Supply voltage	$V_S$	7.5	13.2	V
Ambient temperature range	$T_A$	- 40	85	°C
Input frequency range	$f_i$	0.01	20	kHz

*Note: In the operating range the functions given in the circuit description are fulfilled.*

### 3.3 AC/DC Characteristics

$V_{10} = 10 \text{ V}; T_A = 25 \text{ }^\circ\text{C}$

Parameter	Symbol	Limit Values			Unit	Test Condition	Test Circuit
		min.	typ.	max.			
Current consumption	$I_{10}$		45		mA		1

#### Signal Section

Gain	$G_{13-1}$		0		dB		1
Gain	$G_{14-1}$		0		dB		1

Analogous values are apply for feeding in on pins 2 and 3.

Gain	$G_{15-28}$		0		dB		1
Gain	$G_{16-28}$		0		dB		1

Analogous values are apply for feeding in on pins 25 and 26.

#### Input Level Control

Min. gain	$G_{13-1}$ $G_{14-1}$ $G_{15-28}$ $G_{16-28}$		0		dB		1
Max. gain	$G_{13-1}$ $G_{14-1}$ $G_{15-28}$ $G_{16-28}$		25		dB	01,0A $V_{inp} 10$	1
Stepwidth	$G_{13-1}$ $G_{14-1}$ $G_{15-28}$ $G_{16-28}$		2.5		dB	01,X-01, $X \pm 1$ $V_{inp} X - V_{inp} (X \pm 1)$	1

Analogous values are apply for feeding in on pins 2, 3, 25 and 26.

Threshold Clipping detector 1	$V_{1 \text{ Cl1}}$ $V_{28 \text{ Cl1}}$		1.9		Vrms		1
-------------------------------	---	--	-----	--	------	--	---

3.3 AC/DC Characteristics (cont'd)

$V_{10} = 10 \text{ V}; T_A = 25 \text{ }^\circ\text{C}$

Parameter	Symbol	Limit Values			Unit	Test Condition	Test Circuit
		min.	typ.	max.			

**Volume Control**

Max. gain	$G_{13-1}$ $G_{14-1}$ $G_{15-28}$ $G_{16-28}$		0		dB		1
Min. gain	$G_{13-1}$ $G_{14-1}$ $G_{15-28}$ $G_{16-28}$		- 78.25		dB	02,00; 03,00 <i>Vol. 0; Loud. OFF</i>	1
Tracking error	$\Delta G_{13-14}$ $\Delta G_{15-16}$ $\Delta G_{13-16}$ $\Delta G_{14-15}$			$\pm 2$	dB	02,3F-02,24; 03,3F <i>Vol. 63-36; Loud. OFF</i>	1
Stepwidth	$\Delta G_{13}$ $\Delta G_{14}$ $\Delta G_{15}$ $\Delta G_{16}$		1.25		dB	02,X-02, ( $X \pm 1$ ) <i>Vol. X-Vol. (<math>X \pm 1</math>)</i>	1

**Loudness Control**

Max. gain	$G_{4-1}$ $G_{24-28}$		- 6		dB	03,7F; 02,00 Loud. ON	1
Min. gain	$G_{4-1}$ $G_{24-28}$		- 84.75		dB	03,40; 02,00 Loud. 0	1
Tracking error	$\Delta G_{5-24}$			$\pm 2$	dB	03,7F-03,64; 02,00 Loud. 63-36; Loud. ON	1
Stepwidth	$\Delta G_4$ $\Delta G_{24}$		1.25		dB	03,X-03, ( $X \pm 1$ ) <i>Loud. X-Loud. (<math>X \pm 1</math>)</i>	1

### 3.3 AC/DC Characteristics (cont'd)

$V_{10} = 10 \text{ V}; T_A = 25 \text{ }^\circ\text{C}$

Parameter	Symbol	Limit Values			Unit	Test Condition	Test Circuit
		min.	typ.	max.			

#### Output Control

Max. gain	$G_{13-1}$ $G_{14-1}$ $G_{15-28}$ $G_{16-28}$		0		dB		1
Min. gain	$G_{13-1}$ $G_{14-1}$ $G_{15-28}$ $G_{16-28}$		- 38.75		dB	08,00; Out 0 07,00; Out 0 05,00; Out 0 06,00; Out 0	1
Stepwidth	$\Delta G_{13}$  $\Delta G_{14}$  $\Delta G_{15}$  $\Delta G_{16}$		1.25		dB	08,X-08, (X ± 1) OutX-Out (X ± 1) 07,X-07, (X ± 1) OutX-Out (X ± 1) 05,X-05, (X ± 1) OutX-Out (X ± 1) 06,X-06, (X ± 1) OutX-Out (X ± 1)	1

### 3.3 AC/DC Characteristics (cont'd)

$V_{10} = 10 \text{ V}; T_A = 25 \text{ }^\circ\text{C}$

Parameter	Symbol	Limit Values			Unit	Test Condition	Test Circuit
		min.	typ.	max.			

#### Bass Control

Bass boost	$G_{13-1}$ $G_{14-1}$ $G_{15-28}$ $G_{16-28}$	14	16		dB	04,80; $f_1 = 40 \text{ Hz}$ <i>Bass min, Treble lin</i>	1
Bass cut	$G_{13-1}$ $G_{14-1}$ $G_{15-28}$ $G_{16-28}$		- 14		dB	04,8F; $f_1 = 40 \text{ Hz}$ <i>Bass min, Treble lin</i>	1
Bass stepwidth	$\Delta G_{13}$ $\Delta G_{14}$ $\Delta G_{15}$ $\Delta G_{16}$	1	2	3	dB	04,8X ( $X \pm 1$ ) <i>BassX-Bass (<math>X \pm 1</math>)</i>	1

#### Treble Control

Treble boost	$G_{13-1}$ $G_{14-1}$ $G_{15-28}$ $G_{16-28}$	14	16		dB	04,80; $f_1 = 15 \text{ kHz}$ <i>Treble max, Bass lin</i>	1
Treble cut	$G_{13-1}$ $G_{14-1}$ $G_{15-28}$ $G_{16-28}$		- 14		dB	04,8F; $f_1 = 15 \text{ kHz}$ <i>Treble min, Bass lin</i>	1
Treble stepwidth	$\Delta G_{13}$ $\Delta G_{14}$ $\Delta G_{15}$ $\Delta G_{16}$	1	2	3	dB	04,8X-04, ( $X \pm 1$ ) 8 <i>TrebleX-Treble (<math>X \pm 1</math>)</i>	1
Tone linearity	$\Delta G_{13}$ $\Delta G_{14}$ $\Delta G_{15}$ $\Delta G_{16}$	1	2	3	dB	04, 88-04, $f_1 = 40 \text{ Hz} \dots 15 \text{ kHz}$ <i>Treble, Bass lin</i>	1
Threshold clipping detector 2	$V_{1 \text{ Cl}2}$ $V_{28 \text{ Cl}2}$		380		mVrms	04,00 $f_1 = 40 \text{ Hz or } 15 \text{ kHz}$ <i>Treble max, Bass max</i>	1

3.3 AC/DC Characteristics (cont'd)

$V_{10} = 10 \text{ V}; T_A = 25 \text{ }^\circ\text{C}$

Parameter	Symbol	Limit Values			Unit	Test Condition	Test Circuit
		min.	typ.	max.			
Channel separation	$\Delta G_{14-15}$ $\Delta G_{13-16}$	80			dB	$V_1$ or $V_{28} = 300 \text{ mVrms}$	1

Analogous values apply for feeding on pins 2, 3, 25 and 26.

Crosstalk attenuation input switch	$a_{in \text{ use/out interf.}}$	80			dB	$V_{i \text{ use.}} = 0$ $V_{i \text{ interf.}} = 300 \text{ mVrms}$	1
------------------------------------	----------------------------------	----	--	--	----	---	---

Feed on pins 1-3 and 25, 26, 28, measured on pins 13-16.

Attenuation mute	$a_{1-13}$ $a_{1-14}$  $a_{28-15}$ $a_{28-16}$	80			dB	02,7F; $V_1 = 300 \text{ mVrms}$ <i>mute active</i> 00,20; $V_1 = 300 \text{ mVrms}$ <i>notselect</i> 02,7F; $V_{28} = 300 \text{ mVrms}$ <i>mute active</i> 00,20; $V_{28} = 300 \text{ mVrms}$ <i>notselect</i>	1
Max. input voltage	$V_1$	2			Vrms	$THD_{13} < 1 \%$ $THD_{14} < 1 \%$	1
	$V_{28}$	2			Vrms	$THD_{15} < 1 \%$ $THD_{16} < 1 \%$	1
Max. output voltage	$V_{13}$	2.2			Vrms	$THD_{13} < 1 \%$ 01,07; $V_{inp.7}$	1
	$V_{14}$					$THD_{14} < 1 \%$ 01,07; $V_{inp.7}$	
	$V_{15}$					$THD_{15} < 1 \%$ 01,07; $V_{inp.7}$	
	$V_{16}$					$THD_{16} < 1 \%$ 01,07; $V_{inp.7}$	
Distortion	$THD_{13}$ $THD_{14}$ $THD_{15}$ $THD_{16}$		0.01	0.05	%	$V_1 = 300 \text{ mVrms}$  $V_{28} = 300 \text{ mVrms}$	1

### 3.3 AC/DC Characteristics (cont'd)

$V_{10} = 10 \text{ V}; T_A = 25 \text{ }^\circ\text{C}$

Parameter	Symbol	Limit Values			Unit	Test Condition	Test Circuit
		min.	typ.	max.			
Analog values apply for feeding in on pins 2, 3, 25 and 26.							
Distortion	$THD_{13}$ $THD_{14}$ $THD_{15}$ $THD_{16}$		0.01	0.1	%	$V_1 = 300 \text{ mVrms}$ 02,2F; 03,6F; Vol. 47 $V_{28} = 300 \text{ mVrms}$ 02,2F; 03,6F; Vol. 47	1
Distortion	$THD_{13}$ $THD_{14}$ $THD_{15}$ $THD_{16}$		0.05	0.2	%	$V_1 = 150 \text{ mVrms}$ 04,XX any tone setting $V_{28} = 150 \text{ mVrms}$ 04,XX any tone setting	1
Unweighted signal/noise ratio	$a_S/N_{13}$ $a_S/N_{14}$ $a_S/N_{15}$ $a_S/N_{16}$		105		dB	$V_{Nrms}$ 20 Hz ... 20 kHz $V_1 = 2 \text{ Vrms}$ $V_{Nrms}$ 20 Hz ... 20 kHz $V_{28} = 2 \text{ Vrms}$	1
Unweighted signal/noise ratio	$a_S/N_{13}$ $a_S/N_{14}$  $a_S/N_{15}$ $a_S/N_{16}$		60		dB	$V_{Nrms}$ 20 Hz ... 20 kHz $V_1 = 0.3 \text{ Vrms}$ 02,27; 03,67 Vol. 39 $V_{Nrms}$ 20 Hz ... 20 kHz $V_{28} = 0.3 \text{ Vrms}$ 02,27; 03,67 Vol. 39	1
Unweighted noise voltage	$V_{N13}$ $V_{N14}$ $V_{N15}$ $V_{N16}$			20	$\mu\text{Vrms}$	$V_{Nrms}$ 20 Hz ... 20 kHz 02,00; 03,00 Vol. 0	1
Bridge power-amp	$\Phi_{13-14}$		180			Bit Ph = '0'	1
Modus	$\Phi_{15-16}$		180			Bit Ph = '0'	1
Load resistor	$R_{L13, 14}$  $R_{L15, 16}$  $R_{L13, 14}$  $R_{L15, 16}$	4.5   1.5			k $\Omega$   k $\Omega$	$V_{13, 14} = 2.5 \text{ V};$ $THD < 1 \%$ $V_{15, 16} = 2.5 \text{ V};$ $THD < 1 \%$ Bit fan = '1' $V_{13, 14} = 2.5 \text{ V};$ $THD < 1 \%$ Bit fan = '1' $V_{15, 16} = 2.5 \text{ V};$ $THD < 1 \%$	1   1
DC jump $\Delta 1$ bit	$\Delta V_{13}$			$\pm 4$	mV	Sub, X-Sub, X $\pm 1$	1



3.3 AC/DC Characteristics (cont'd)

$V_{10} = 10\text{ V}; T_A = 25\text{ }^\circ\text{C}$

Parameter	Symbol	Limit Values			Unit	Test Condition	Test Circuit
		min.	typ.	max.			
Analog values apply for measuring on pins 14, 15 and 16.							
DC jump $\Delta 1$ bit	$\Delta V_{13}$			$\pm 6$	mV	01, 03-01, 04-01, 05-01, 06-01, 07 <i>Input level control</i>	1
DC jump $\Delta 1$ bit	$\Delta V_{13}$			$\pm 10$	mV	01, 07-01, 08-01, 09-01, 0A-01, 08 <i>Input level control</i>	1
PSRR Power supply Ripple rejection	$a_{\text{PSRR}13}$		70		dB	$V_{i\text{ interf.}} = 1\text{ V}_{\text{rms}}$ $f_{i\text{ interf.}} = 100\text{ Hz} \dots 20\text{ kHz}$ $R_G = 220\ \Omega$ $R_G = 220\ \Omega$ Measurement CCIR 651 Effective	1
	$a_{\text{PSRR}14}$		70		dB		1
	$a_{\text{PSRR}15}$		70		dB		1
	$a_{\text{PSRR}16}$		70		dB		1
Zero crossing detector window			$\pm 30$		mV		1
Mute active	$V_{\text{QML}}$	0.3		1.5	V		1
Mute inactive	$V_{\text{QMH}}$	3		5.5	V		1
Input current	$I_{\text{QH}}$			50	$\mu\text{A}$		1
	$I_{\text{QL}}$			100	$\mu\text{A}$		1

Design Hints

Input resistance	$R_1$ $R_2$ $R_3$ $R_{25}$ $R_{26}$ $R_{28}$	30			k $\Omega$		
Output resistance	$R_{13}$ $R_{14}$ $R_{15}$ $R_{16}$			70	$\Omega$		

**3.3 AC/DC Characteristics (cont'd)**

$V_{10} = 10\text{ V}; T_A = 25\text{ °C}$

Parameter	Symbol	Limit Values			Unit	Test Condition	Test Circuit
		min.	typ.	max.			

**I<sup>2</sup>C Bus (SCL, SDA)**

**SCL, SDA Edges**

Rise time	$t_R$			1	$\mu\text{s}$		
Fall time	$t_F$			300	ns		

**Shift Register Clock Pulse SCL**

Frequency	$f_{SCL}$	0		100	kHz		
H pulse width	$t_{High}$	4			$\mu\text{s}$		
L pulse width	$t_{Low}$	4			$\mu\text{s}$		

**Start**

Set-up time	$t_{SUSTA}$	4			$\mu\text{s}$		
Hold time	$t_{HDSTA}$	4			$\mu\text{s}$		

**Stop**

Set-up time	$t_{SUSTO}$	4			$\mu\text{s}$		
Bus free time	$t_{BUF}$	4			$\mu\text{s}$		

**Data Transfer**

Set-up time	$t_{SUDAT}$	250			ns		
Hold time	$t_{HDDAT}$	1			$\mu\text{s}$		

**Input SCL, SDA**

Input voltage	$V_{QH}$	3		5.5	V		1
	$V_{QL}$			1.5			
Input current	$I_{QH}$	3		50	$\mu\text{A}$		1
	$I_{QL}$			100			

**3.3 AC/DC Characteristics (cont'd)**

$V_{10} = 10 \text{ V}; T_A = 25 \text{ }^\circ\text{C}$

Parameter	Symbol	Limit Values			Unit	Test Condition	Test Circuit
		min.	typ.	max.			

**Output SDA (open collector)**

Output voltage	$V_{QH}$ $V_{QL}$	5.5		0.4	V	$R_L = 2.5 \text{ k}\Omega$ $I_{QL} = 3 \text{ mA}$	1
----------------	----------------------	-----	--	-----	---	--	---

*Note: The listed characteristics are ensured over the operating range of the integrated circuit. Typical characteristics specify mean values expected over the production spread. If not otherwise specified, typical characteristics apply at  $T_A = 25^\circ\text{C}$  and the given supply voltage.*

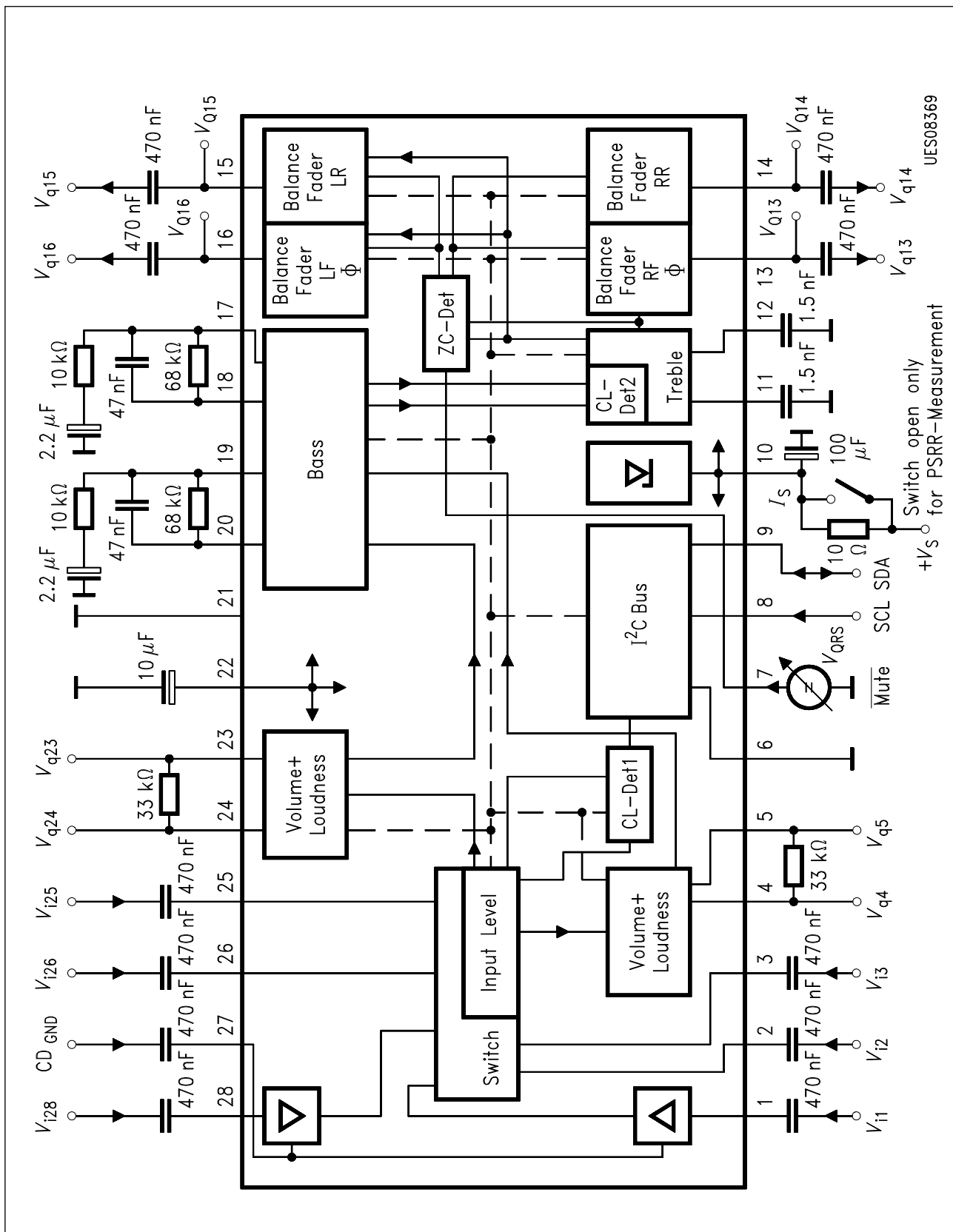

Figure 15  
Test Circuit

Application Circuit 1

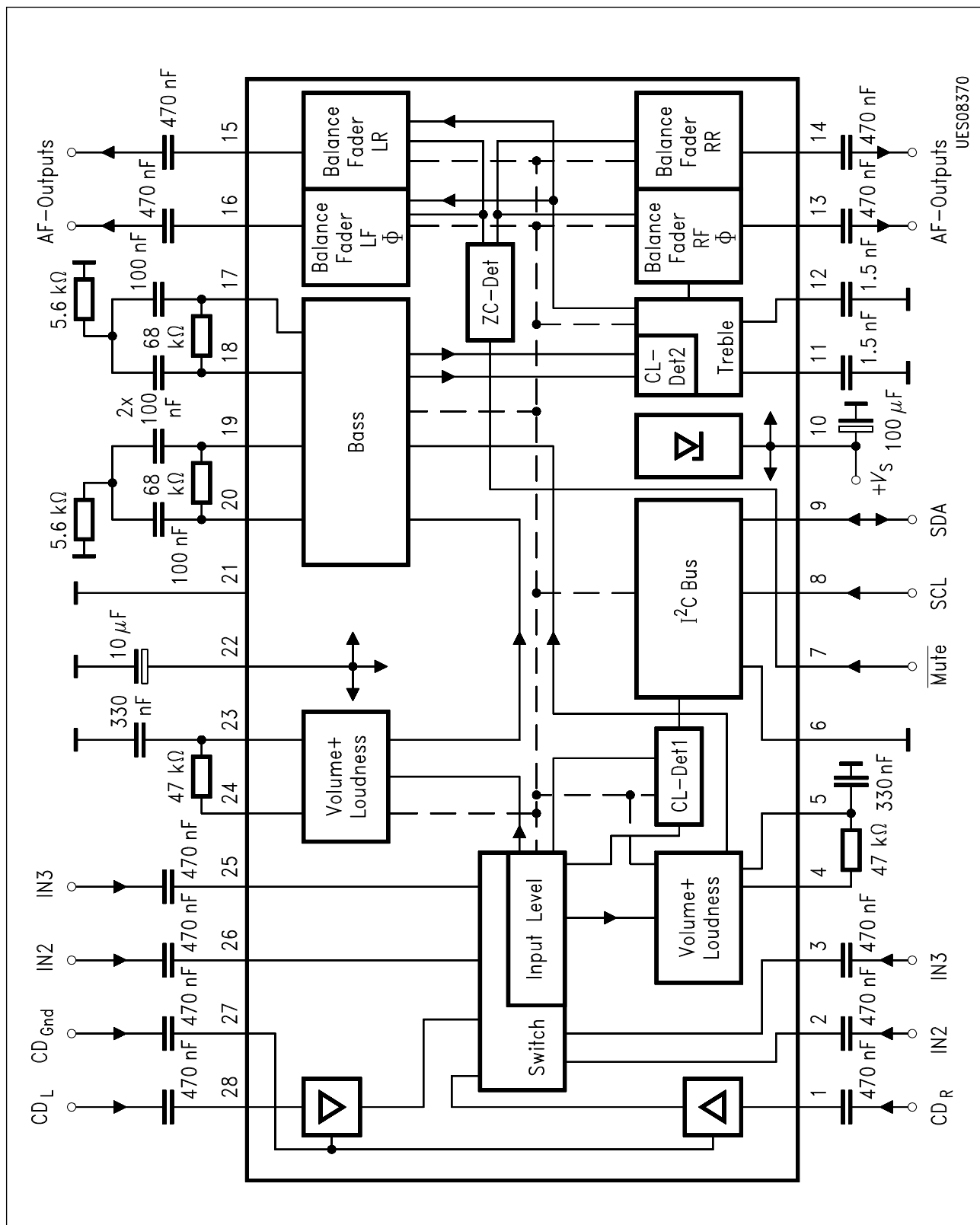

Figure 16  
Bass Loudness Circuitry and Bass Control Resonance Characteristic

Application Circuit 2

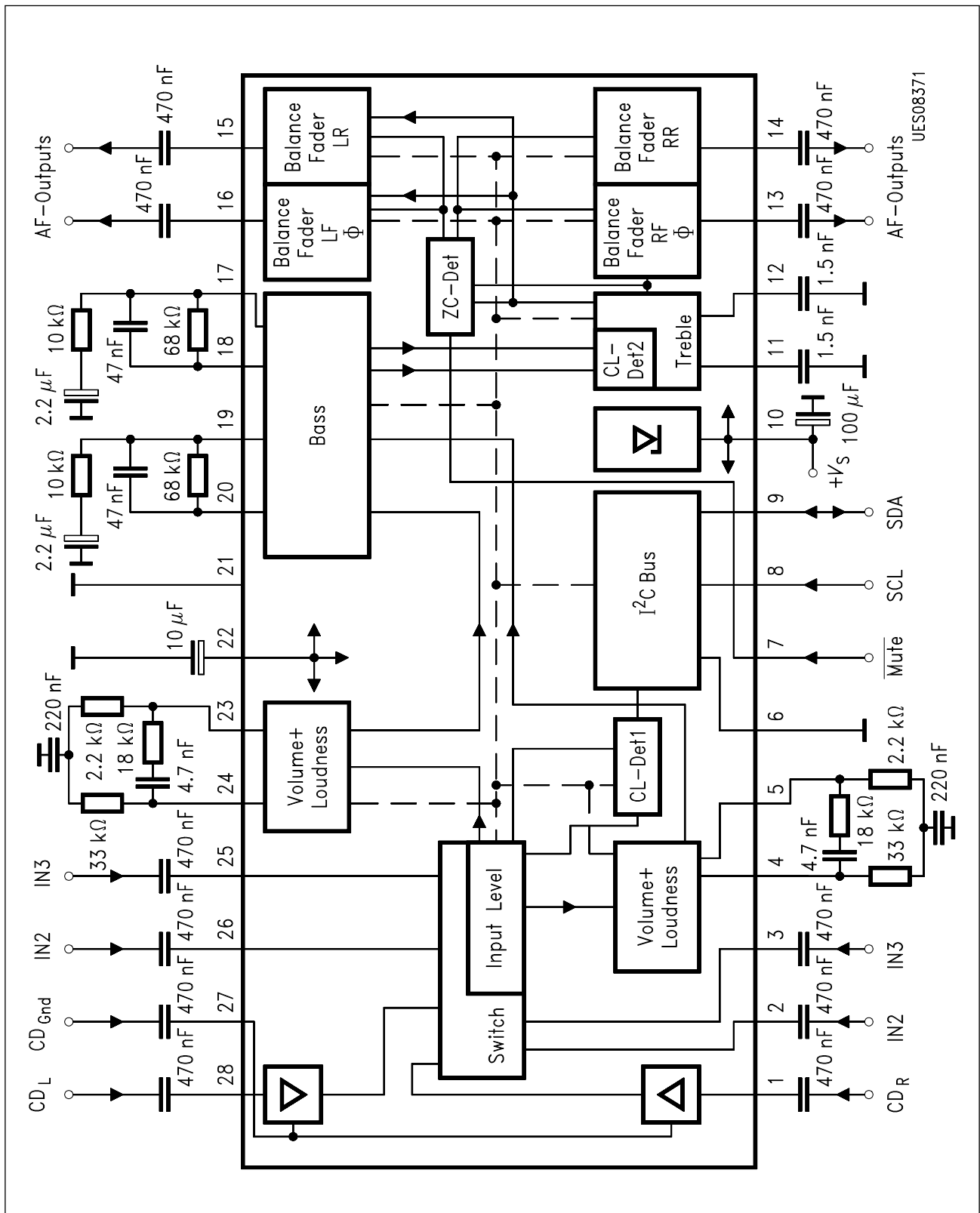
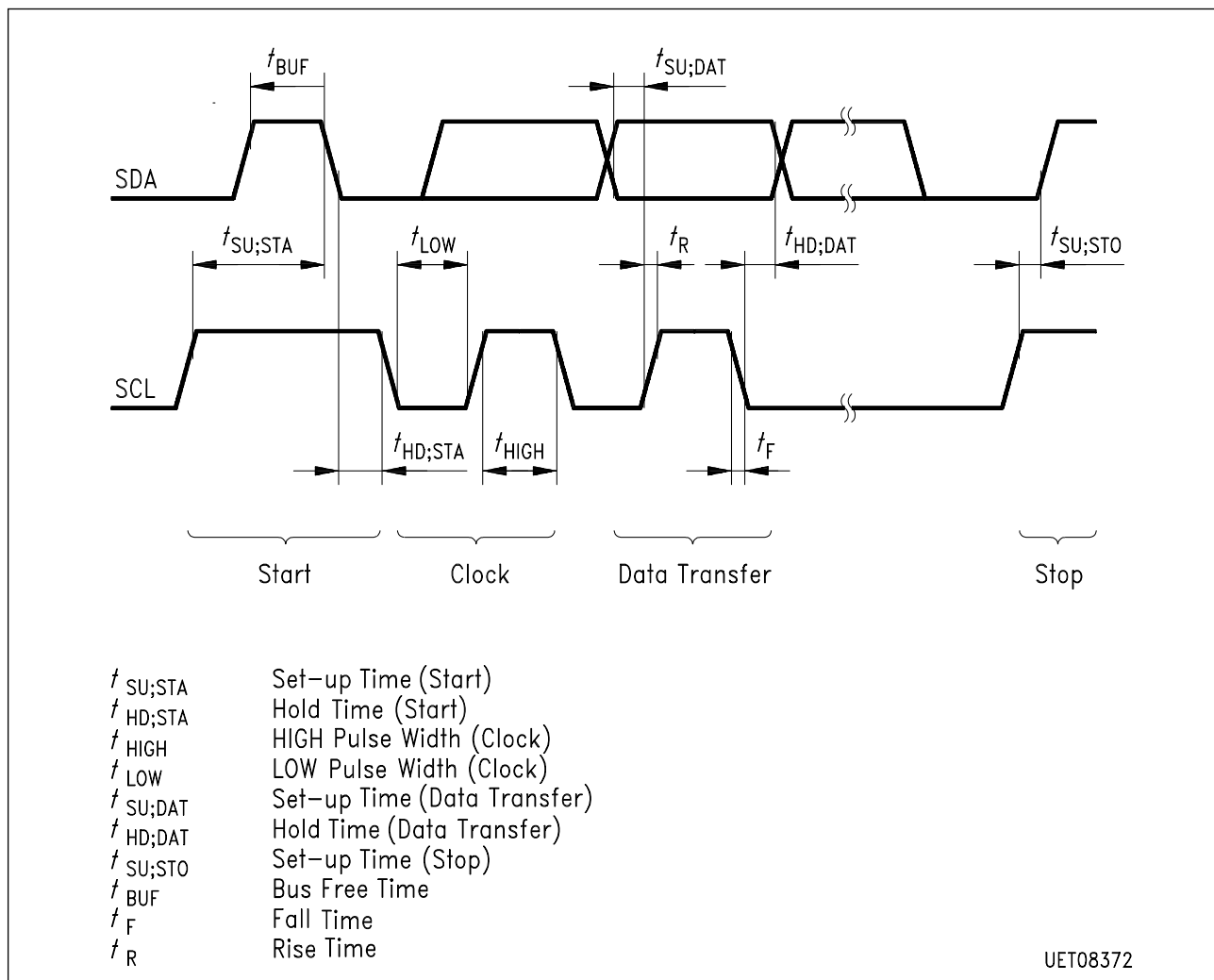

Figure 17  
Bass/Treble Loudness Circuitry and 1. Order Bass Control Characteristic

Diagram



**Figure 18**  
**I<sup>2</sup>C Bus Timing**

4 Package Outlines

**P-DSO-28-1**  
(Plastic Dual Small Outline Package)

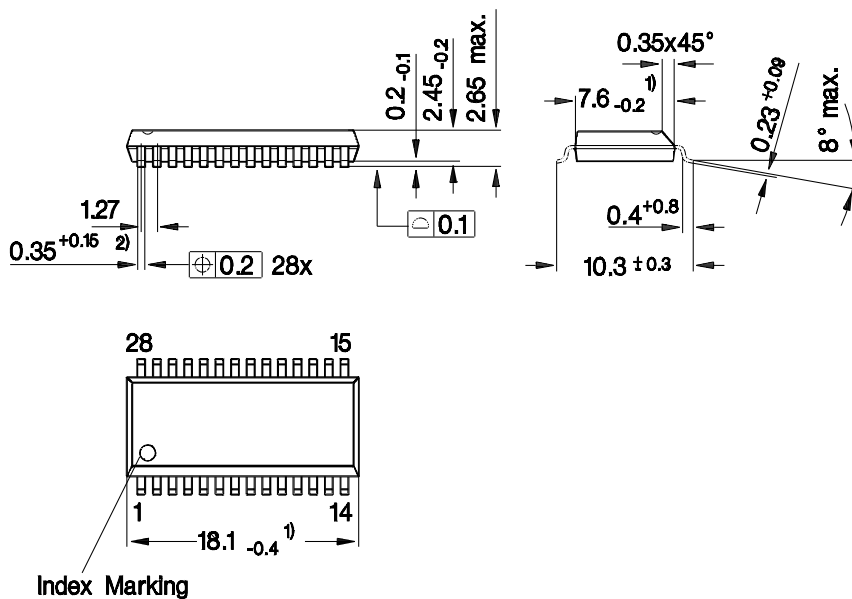

- 1) Does not include plastic or metal protrusion of 0.15 max. per side
- 2) Does not include dambar protrusion

GPS05123

**Sorts of Packing**

Package outlines for tubes, trays etc. are contained in our Data Book "Package Information".

SMD = Surface Mounted Device

Dimensions in mm