

GENERAL PURPOSE APPLICATION.
SWITCHING APPLICATION.

FEATURES

- Low Leakage Current
: $I_{CEX}=50nA(\text{Max.}), I_{BL}=50nA(\text{Max.})$
@ $V_{CE}=30V, V_{EB}=3V$.
- Excellent DC Current Gain Linearity.
- Low Saturation Voltage
: $V_{CE(\text{sat})}=0.3V(\text{Max.}) @ I_C=50mA, I_B=5mA$.
- Low Collector Output Capacitance
: $C_{ob}=4pF(\text{Max.}) @ V_{CB}=5V$.
- Complementary to 2N3906C.

MAXIMUM RATINGS ($T_a=25^\circ\text{C}$)

CHARACTERISTIC	SYMBOL	RATING	UNIT
Collector-Base Voltage	V_{CBO}	60	V
Collector-Emitter Voltage	V_{CEO}	40	V
Emitter-Base Voltage	V_{EBO}	6	V
Collector Current	I_C	200	mA
Base Current	I_B	50	mA
Collector Power Dissipation	$T_a=25^\circ\text{C}$	625	mW
	$T_c=25^\circ\text{C}$	1.5	W
Junction Temperature	T_j	150	$^\circ\text{C}$
Storage Temperature Range	T_{stg}	-55~150	$^\circ\text{C}$

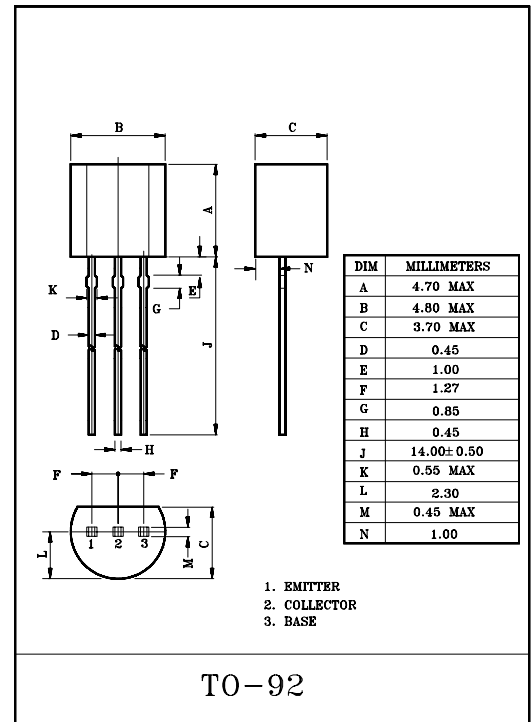

2N3904C

ELECTRICAL CHARACTERISTICS (Ta=25°C)

CHARACTERISTIC		SYMBOL	TEST CONDITION	MIN.	TYP.	MAX.	UNIT
Collector Cut-off Current		I_{CEX}	$V_{CE}=30V, V_{EB}=3V$	-	-	50	nA
Base Cut-off Current		I_{BL}	$V_{CE}=30V, V_{EB}=3V$	-	-	50	nA
Collector-Base Breakdown Voltage		$V_{(BR)CBO}$	$I_C=10\mu A, I_E=0$	60	-	-	V
Collector-Emitter Breakdown Voltage *		$V_{(BR)CEO}$	$I_C=1mA, I_B=0$	40	-	-	V
Emitter-Base Breakdown Voltage		$V_{(BR)EBO}$	$I_E=10\mu A, I_C=0$	6.0	-	-	V
DC Current Gain	*	$h_{FE}(1)$	$V_{CE}=1V, I_C=0.1mA$	40	-	-	
		$h_{FE}(2)$	$V_{CE}=1V, I_C=1mA$	70	-	-	
		$h_{FE}(3)$	$V_{CE}=1V, I_C=10mA$	100	-	300	
		$h_{FE}(4)$	$V_{CE}=1V, I_C=50mA$	60	-	-	
		$h_{FE}(5)$	$V_{CE}=1V, I_C=100mA$	30	-	-	
Collector-Emitter Saturation Voltage	*	$V_{CE(sat)1}$	$I_C=10mA, I_B=1mA$	-	-	0.2	V
		$V_{CE(sat)2}$	$I_C=50mA, I_B=5mA$	-	-	0.3	
Base-Emitter Saturation Voltage	*	$V_{BE(sat)1}$	$I_C=10mA, I_B=1mA$	0.65	-	0.85	V
		$V_{BE(sat)2}$	$I_C=50mA, I_B=5mA$	-	-	0.95	
Transition Frequency		f_T	$V_{CE}=20V, I_C=10mA, f=100MHz$	300	-	-	MHz
Collector Output Capacitance		C_{ob}	$V_{CB}=5V, I_E=0, f=1MHz$	-	-	4.0	pF
Input Capacitance		C_{ib}	$V_{BE}=0.5V, I_C=0, f=1MHz$	-	-	8.0	pF
Input Impedance		h_{ie}	$V_{CE}=10V, I_C=1mA, f=1kHz$	1.0	-	10	k Ω
Voltage Feedback Ratio		h_{re}		0.5	-	8.0	$\times 10^{-4}$
Small-Signal Current Gain		h_{fe}		100	-	400	
Collector Output Admittance		h_{oe}		1.0	-	40	μS
Noise Figure		NF		$V_{CE}=5V, I_C=0.1mA$ $R_g=1k\Omega, f=10Hz \sim 15.7kHz$	-	-	5.0
Switching Time	Delay Time	t_d		-	-	35	nS
	Rise Time	t_r		-	-	35	
	Storage Time	t_{stg}		-	-	200	
	Fall Time	t_f		-	-	50	

*Pulse Test : Pulse Width $\leq 300\mu S$, Duty Cycle $\leq 2\%$