

### APPLICATIONS

- Rectification
- Freewheel Diode
- DC Motor Control
- Power Supplies
- Welding
- Battery Chargers

### FEATURES

- Double Side Cooling
- High Surge Capability

### VOLTAGE RATINGS

Type Number	Repetitive Peak Reverse Voltage $V_{RRM}$ V	Conditions
TR402ST14	1400	$V_{RSM} = V_{RRM} + 100V$
TR402ST13	1300	
TR402ST12	1200	
TR402ST11	1100	
TR402ST10	1000	
TR402ST09	900	

Lower voltage grades available.

### KEY PARAMETERS

$V_{RRM}$	<b>1400V</b>
$I_{F(AV)}$	<b>505A</b>
$I_{FSM}$	<b>5600A</b>

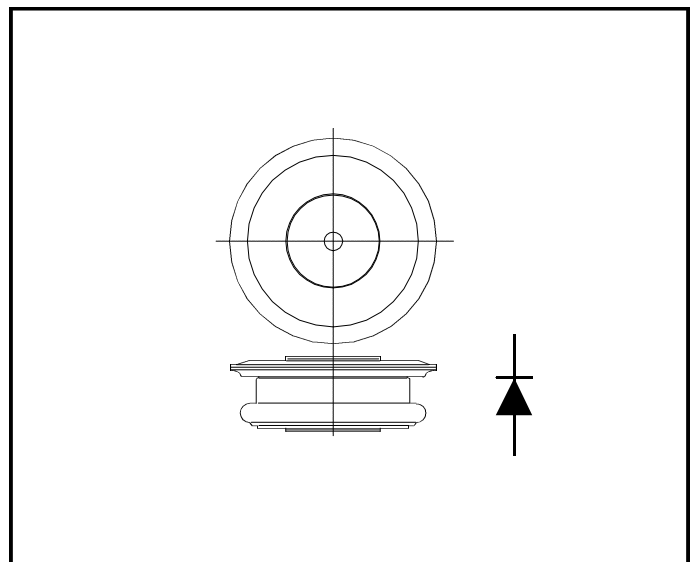

Outline type code: T.  
See Package Details for further information.

### CURRENT RATINGS

Symbol	Parameter	Conditions	Max.	Units
<b>Double Side Cooled</b>				
$I_{F(AV)}$	Mean forward current	Half wave resistive load, $T_{case} = 100^{\circ}C$	505	A
$I_{F(RMS)}$	RMS value	$T_{case} = 100^{\circ}C$	793	A
$I_F$	Continuous (direct) forward current	$T_{case} = 100^{\circ}C$	640	A
<b>Single Side Cooled (Anode side)</b>				
$I_{F(AV)}$	Mean forward current	Half wave resistive load, $T_{case} = 100^{\circ}C$	365	A
$I_{F(RMS)}$	RMS value	$T_{case} = 100^{\circ}C$	573	A
$I_F$	Continuous (direct) forward current	$T_{case} = 100^{\circ}C$	390	A

# TR402ST

## SURGE RATINGS

Symbol	Parameter	Conditions	Max.	Units
$I_{FSM}$	Surge (non-repetitive) forward current	10ms half sine; $T_{case} = 175^{\circ}C$ $V_R = 50\% V_{RRM} - 1/4$ sine	4.5	kA
$I^2t$	$I^2t$ for fusing		$101 \times 10^3$	A <sup>2</sup> s
$I_{FSM}$	Surge (non-repetitive) forward current	10ms half sine; $T_{case} = 175^{\circ}C$ $V_R = 0$	5.6	kA
$I^2t$	$I^2t$ for fusing		$155 \times 10^3$	A <sup>2</sup> s

## THERMAL AND MECHANICAL DATA

Symbol	Parameter	Conditions	Min.	Max.	Units	
$R_{th(j-c)}$	Thermal resistance - junction to case	Double side cooled	dc	-	0.08	$^{\circ}C/W$
		Single side cooled	Anode dc	-	0.16	$^{\circ}C/W$
			Cathode dc	-	0.16	$^{\circ}C/W$
$R_{th(c-h)}$	Thermal resistance - case to heatsink	Clamping force 4.5kN with mounting compound	Double side	-	0.02	$^{\circ}C/W$
			Single side	-	0.04	$^{\circ}C/W$
$T_{vj}$	Virtual junction temperature	On-state (conducting)		-	185	$^{\circ}C$
		Reverse (blocking)		-	175	$^{\circ}C$
$T_{stg}$	Storage temperature range		-55	200	$^{\circ}C$	
-	Clamping force		3.5	5.0	kN	

## CHARACTERISTICS

Symbol	Parameter	Conditions	Min.	Max.	Units
$V_{FM}$	Forward voltage	At 450A peak, $T_{case} = 25^{\circ}C$	-	1.25	V
$I_{RRM}$	Peak reverse current	At $V_{RRM}$ , $T_{case} = 175^{\circ}C$	-	15	mA
$V_{TO}$	Threshold voltage	At $T_{vj} = 175C$	-	0.81	V
$r_T$	Slope resistance	At $T_{vj} = 175C$	-	0.84	m $\Omega$

## CURVES

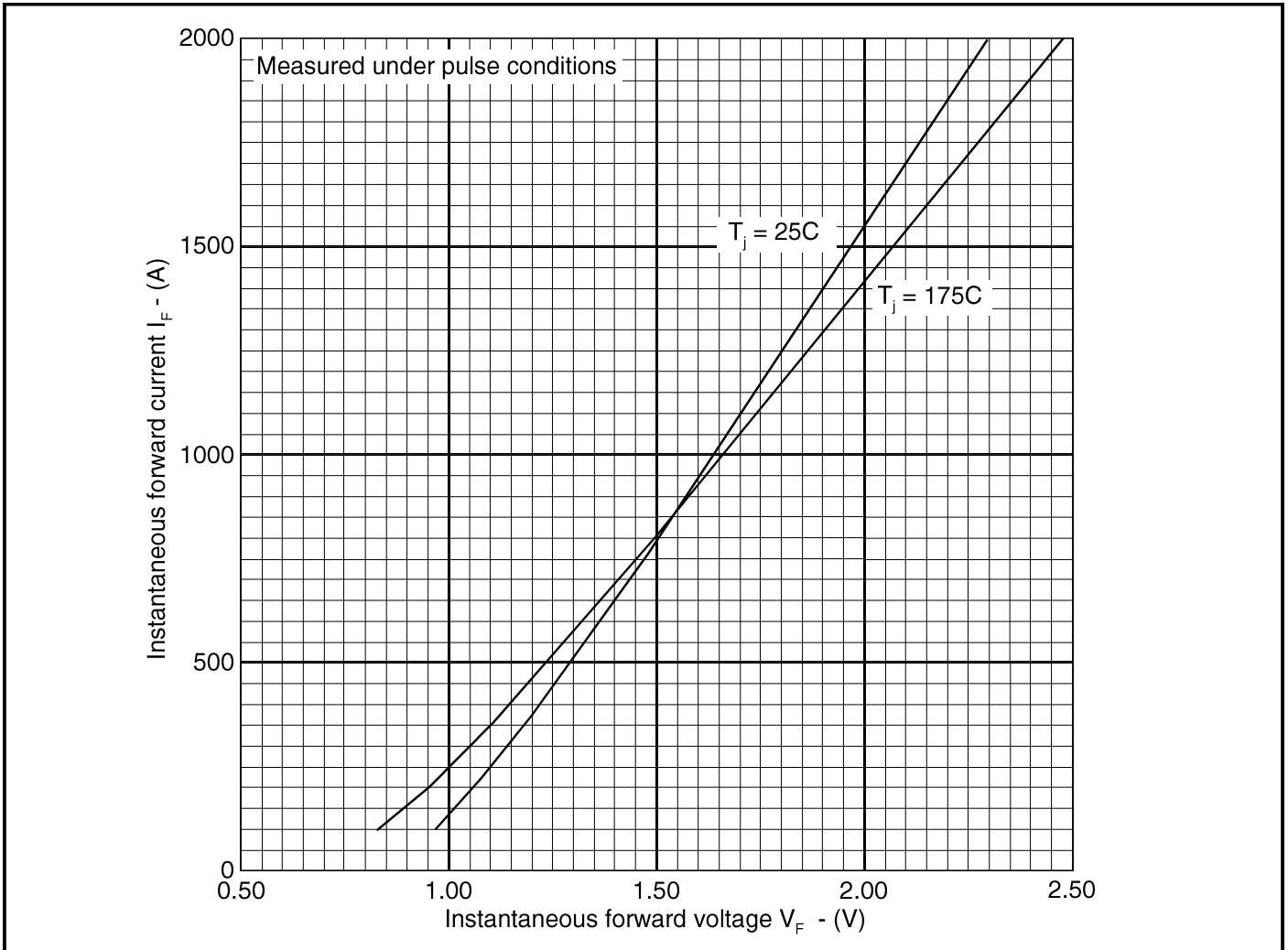

Fig. 1 Maximum (limit) forward characteristics

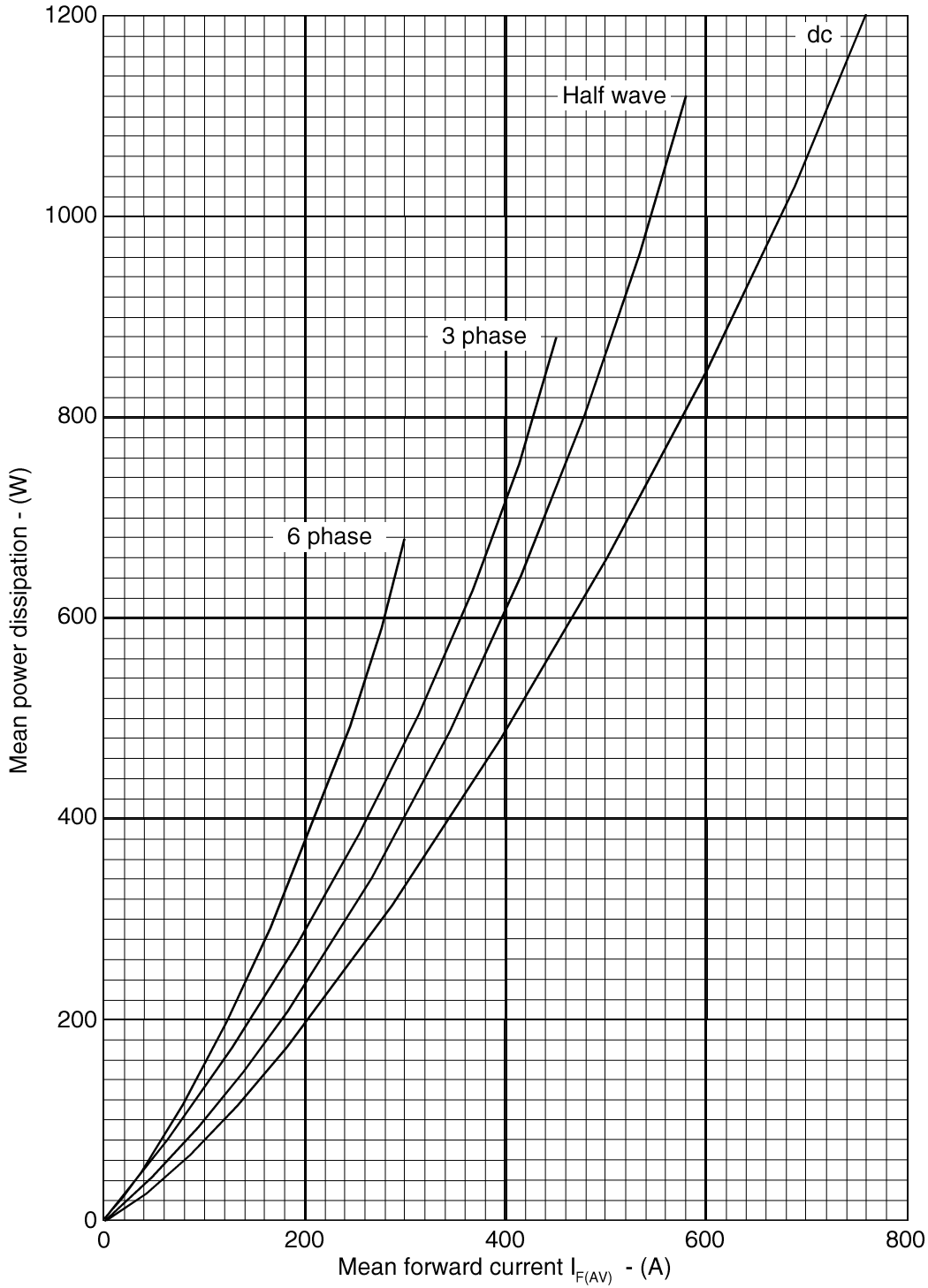

Fig. 2 Dissipation curves

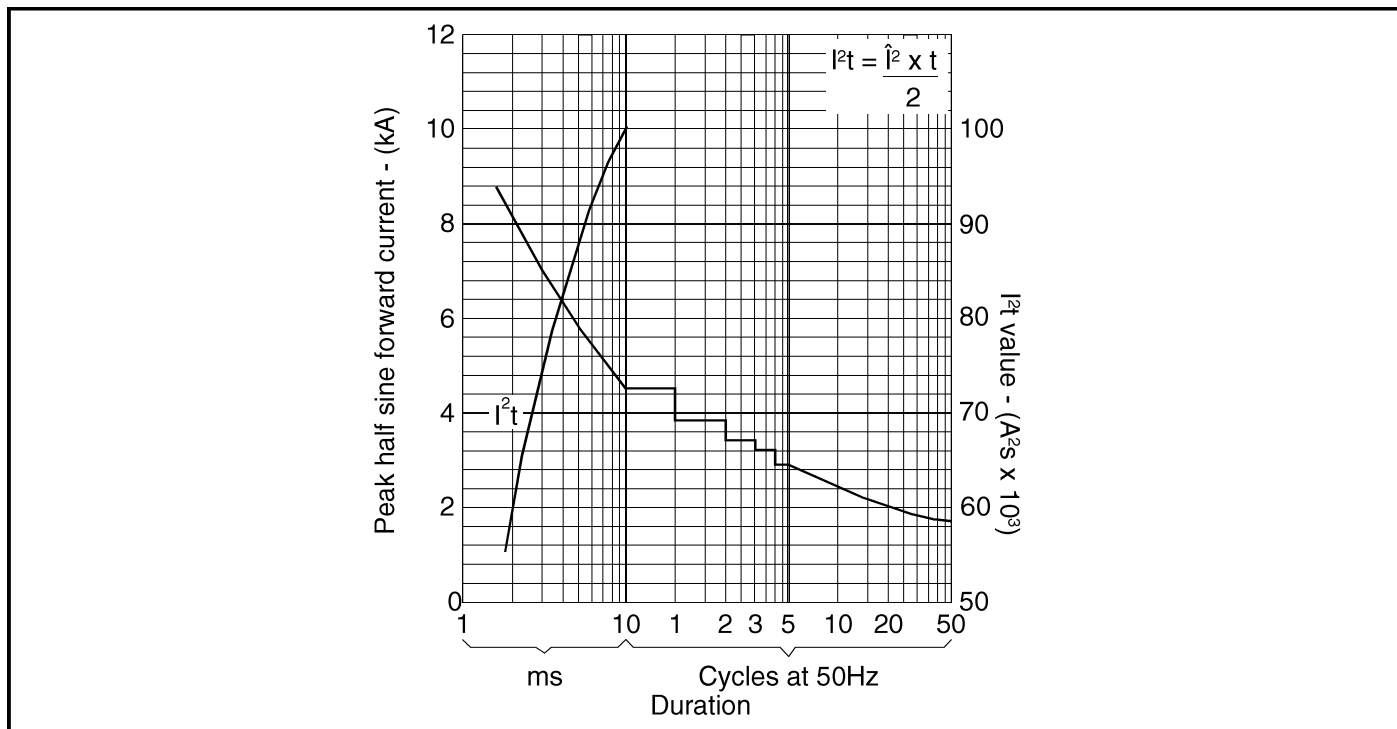

Fig. 3 Surge (non-repetitive) forward current vs time (with 50%  $V_{RRM}$ ,  $T_{case} = 175C$ )

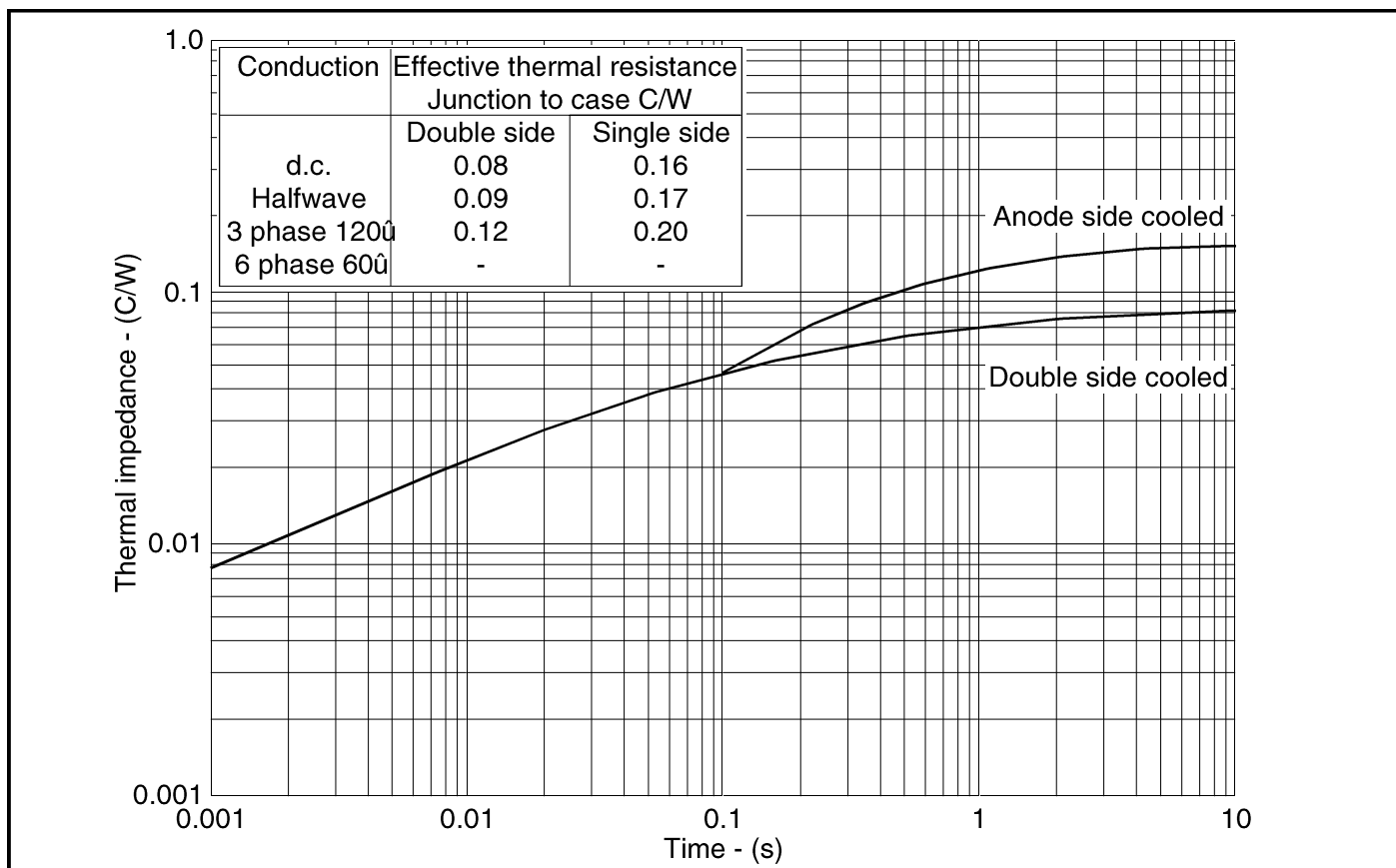

Fig. 4 Transient thermal impedance - junction to case - (C/W)

# TR402ST

## PACKAGE DETAILS

For further package information, please contact your local Customer Service Centre. All dimensions in mm, unless stated otherwise. DO NOT SCALE.

