HD66420

(RAM-Provided 160 Channel 4-Level Grey Scale Driver for Dot Matrix Graphics LCD)

HITACHI

Description

The HD66420 drives and controls a dot matrix graphic LCD(Liquid Crystal Display) using a bit-mapped method. It provides a highly flexible display through its on-chip display RAM, in which each two bits of data can be used to turn on or off one dot on LCD panel with four-level grey scale.

A single HD66420 can display a maximum of 160x80 dots using its powerful display control functions. It can display only eight lines out of eighty lines. This function realize low power consumption because high voltage for driving LCD is not needed.

An MPU can access HD66420 at any time, because the MPU operations are asynchronous with the HD66420's system clock and display operation.

Its low-voltage operation at 2.2 to 5.5V and standby function provides low power dissipation, making the HD66420 suitable for small portable device applications.

Features

- Built-in bit-mapped display RAM: 25.6kbits (160 × 80 × 2 bits)
- Grey scale display: PWM four-level grey scale can be selected from 32 levels
- Grey scale memory management: Packed pixel
- Partial display: Eight-lines data can be displayed in any place
- An 80-system MPU interface
- Power supply voltage for operation : 2.2V to 5.5V
- Power supply voltage for LCD : 13 V max.
- Selectable multiplex duty ratio: 1/8, 1/32, 1/64, 1/80
- Built-in oscillator: external resister
- Low power consumption:
 - 55μA typ. 80μA max. during display
 - 0.1μA typ. 5μA max. during standby
- Circuits for generating LCD driving voltage : Contrast control, Operational amplifier, and Resistive dividers
- Internal resistive divider: programmable bias rate
- 32-level programmable contrast control

HD66420

- Wide range of instructions reversible display, display on/off, vertical display scroll, blink, reversible address, read-modify-write mode
- Package: TCP

Ordering Information

Type No.	Package
HD66420TA0	TCP

Pin Arrangement

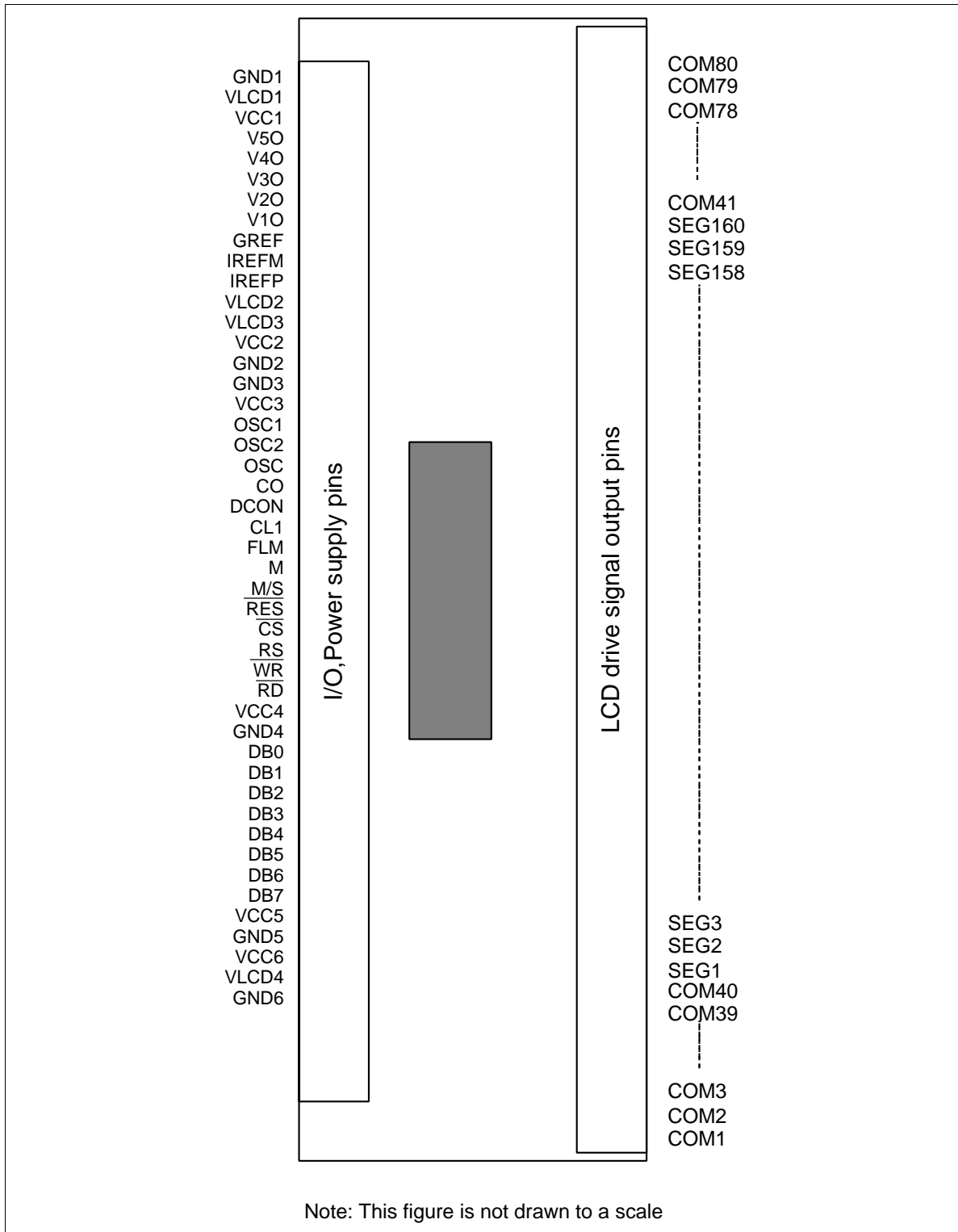

HD66420

Pin Description

Pin Name	Number of Pins	I/O	Connected to	Description
V _{cc} 1–6, GND1–6	12	—	Power supply	V _{cc} : +2.2V to +5.5V, GND: 0V
VLCD1–4	4	—	Power supply	Power supply to LCD driving circuit
V10, V20, V30, V40, V50	5	—	V1 to V5 of HD66420	Several levels of power to the LCD driving outputs. Master HD66420 outputs these levels to the slave HD66420.
OSC	1	I	Oscillator resistor or external clock	Must be connected to external resistor when using R-C oscillation. When using an external clock, it must be input to the OSC terminal.
OSC1, OSC2	2	I/O		
CO	1	O	OSC of Slave HD66420	Clock output
DCON	1	O	External DC/DC convertor	Controls on/off switch of external DC/DC convertor
CL1	1	I/O	CL1 of HD66420	Line clock
FLM	1	I/O	FLM of HD66420	Frame signal
M	1	I/O	M of HD66420	Converts LCD driving outputs to AC
M/S	1	I	V _{cc} or GND	Specifies master/slave mode.
RES	1	I	—	Reset the LSI internally when drive low.
$\overline{\text{CS}}$	1	I	MPU	Select the LSI, specifically internal registers (index and data registers) when driven low.
RS	1	I	MPU	Select one of the internal registers; select the index register when driven low and data registers when driven low.
$\overline{\text{WR}}$	1	I	MPU	Inputs write strobe; allows a write access when driven low.
$\overline{\text{RD}}$	1	I	MPU	Inputs read strobe; allows a read access when driven low.
DB7 to DB0	8	I/O	MPU	8-bits three-state bidirectional data bus; transfer data between the HD66420 and MPU through this bus.
SEG1 to SEG160	160	O	LCD	Output column drive signals
COM1 to COM80	80	O	LCD	Output row drive signals
IREFP	1	—	V _{cc}	Power supply for internal operation amplifier
IREFM	1	—	External resistor	Bias current for internal operational amplifier
REF	1	—	GND	Power supply for internal operation amplifier

Register List

CS	RS	Index Reg.Bits					Register Name	R/W	Data bits											
		4	3	2	1	0			7	6	5	4	3	2	1	0				
1	-	-	-	-	-	-	-													
0	0	-	-	-	-	IR	Index register	W					IR4	IR3	IR2	IR1	IR0			
0	1	0	0	0	0	0	R0	Control register 1	W	RMW	DISP	STBY	PWR	AMP	REV	HOLT	ADC			
0	1	0	0	0	0	1	R1	Control register 2	W	BIS1	BIS0	WLS	GRAY	DTY1	DTY0	INC	BLK			
0	1	0	0	0	1	0	R2	X address register	W				XA5	XA4	XA3	XA2	XA1	XA0		
0	1	0	0	0	1	1	R3	Y address register	W				YA6	YA5	YA4	YA3	YA2	YA1	YA0	
0	1	0	0	1	0	0	R4	Display RAM access register	R/W	D7	D6	D5	D4	D3	D2	D1	D0			
0	1	0	0	1	0	1	R5	Display start line register	W		ST6	ST5	ST4	ST3	ST2	ST1	ST0			
0	1	0	0	1	1	0	R6	Blink start line register	W		BSL6	BSL5	BSL4	BSL3	BSL2	BSL1	BSL0			
0	1	0	0	1	1	1	R7	Blink end line register	W		BEL6	BEL5	BEL4	BEL3	BEL2	BEL1	BEL0			
0	1	0	1	0	0	0	R8	Blink register 1	W	BK0	BK1	BK2	BK3	BK4	BK5	BK6	BK7			
0	1	0	1	0	0	1	R9	Blink register 2	W	BK8	BK9	BK10	BK11	BK12	BK13	BK14	BK15			
0	1	0	1	0	1	0	R10	Blink register 3	W					BK16	BK17	BK8	BK9			
0	1	0	1	0	1	1	R11	Partial display block register	W					PB3	PB2	PB1	PB0			
0	1	0	1	1	0	0	R12	Gray scale palette 1 (0, 0)	W					GP14	GP13	GP12	GP11	GP10		
0	1	0	1	1	0	1	R13	Gray scale palette 2 (0, 1)	W					GP24	GP23	GP22	GP21	GP20		
0	1	0	1	1	1	0	R14	Gray scale palette 3 (1, 0)	W					GP34	GP33	GP32	GP31	GP30		
0	1	0	1	1	1	1	R15	Gray scale palette 4 (1, 1)	W					GP44	GP43	GP42	GP41	GP40		
0	1	1	0	0	0	0	R16	Contrast control register	W		CM1	CM0	CC4	CC3	CC2	CC1	CC0			
0	1	1	0	0	0	1	R17	Reserved	-											
0	1	1	0	0	1	0	R18	Reserved	-											
0	1	1	0	0	1	1	R19	Reserved	-											
0	1	1	0	1	0	0	R20	Reserved	-											
0	1	1	0	1	0	1	R21	Reserved	-											
0	1	1	0	1	1	0	R22	Reserved	-											
0	1	1	0	1	1	1	R23	Reserved	-											
0	1	1	1	0	0	0	R24	Reserved	-											
0	1	1	1	0	0	1	R25	Reserved	-											
0	1	1	1	0	1	0	R26	Reserved	-											
0	1	1	1	0	1	1	R27	Reserved	-											
0	1	1	1	1	0	0	R28	Reserved	-											
0	1	1	1	1	0	1	R29	Reserved	-											
0	1	1	1	1	1	0	R30	Reserved	-											
0	1	1	1	1	1	1	R31	Reserved	-											

HD66420

RMW

RMW = 1: Read-modify-write mode; Address is incremented only after write access

RMW = 0: Address is incremented after both write and read access

DISP

DISP = 1: Display on

DISP = 0: Display off

STBY

STBY = 1: Internal operation and power circuit halt; display off

STBY = 0: Normal operation

PWR

PWR = 1: Output 'High' from DCON

PWR = 0: Output 'Low' from DCON

AMP

AMP = 1: OP amp enable

AMP = 0: OP amp disable

REV

REV = 1: Reverse display

REV = 0: Normal display

HOLT

HOLT = 1: Internal operation stops, Oscillator works

HOLT = 0: Internal operation starts

ADC

ADC = 1: Data in X address H'0 is output from SEG160

ADC = 0: Data in X address H'0 is output from SEG1

BIS1, 0

BIS1, 0 = (1,1): 1/6 LCD drive levels bias ratio

BIS1, 0 = (1,0): 1/7 LCD drive levels bias ratio

BIS1, 0 = (0,1): 1/8 LCD drive levels bias ratio

BIS1, 0 = (0,0): 1/9 LCD drive levels bias ratio

WLS

WLS = 1: 6-bit data is valid

WLS = 0: 8-bit data is valid

GRAY

GRAY = 1: Grayscale palette is available(gray scales can be selected from 32-levels)

GRAY = 0: Grayscale palette is not available(4-gray scales fixed)

DTY1, 0

DTY1, 0 = (1,1): 1/8 display duty cycle - Partial display

DTY1, 0 = (1,0): 1/32 display duty cycle

DTY1, 0 = (0,1): 1/64 display duty cycle

DTY1, 0 = (0,0): 1/80 display duty cycle

INC

INC = 1: X address is incremented for each access

INC = 0: Y address is incremented for each access

BLK

BLK = 1: Blink function is used

BLK = 0: Blink function is not used

HD66420

Block Diagram

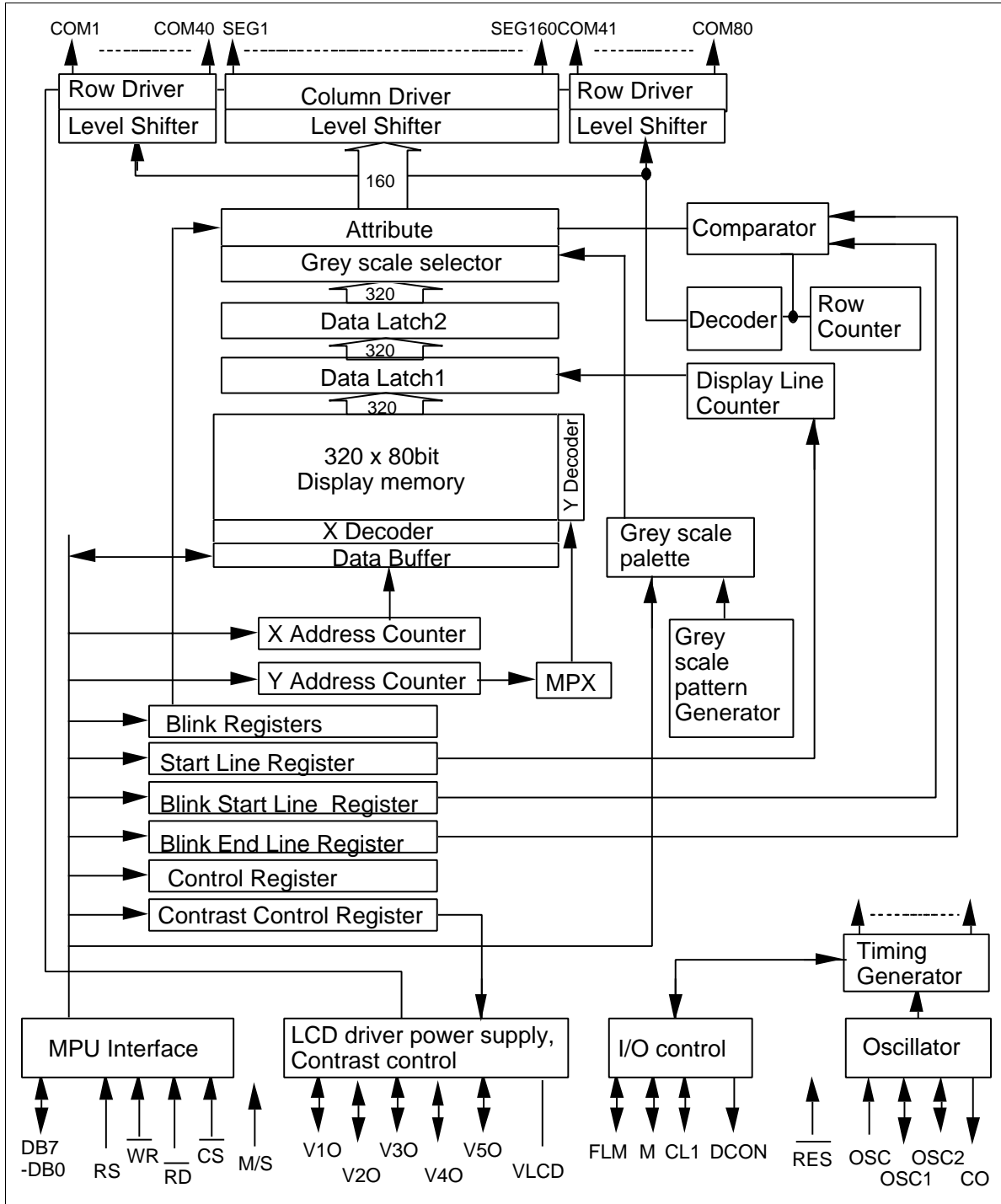

System Description

The HD66420 can display a maximum of 160×80 dots (ten 16x16-dot characters \times 5 lines) four-level gray scale or four colour LCD panel. Four levels of gray scale can be selected from 32-levels, so the appropriate 4-level gray scale can be displayed.

The HD66420 can reduce power dissipation without affecting display because data is retained in the display RAM even during standby modes. An LCD system can be configured simply by attaching external power supply, capacitors and resistors (figure 1) since the HD66420 incorporates power circuits.

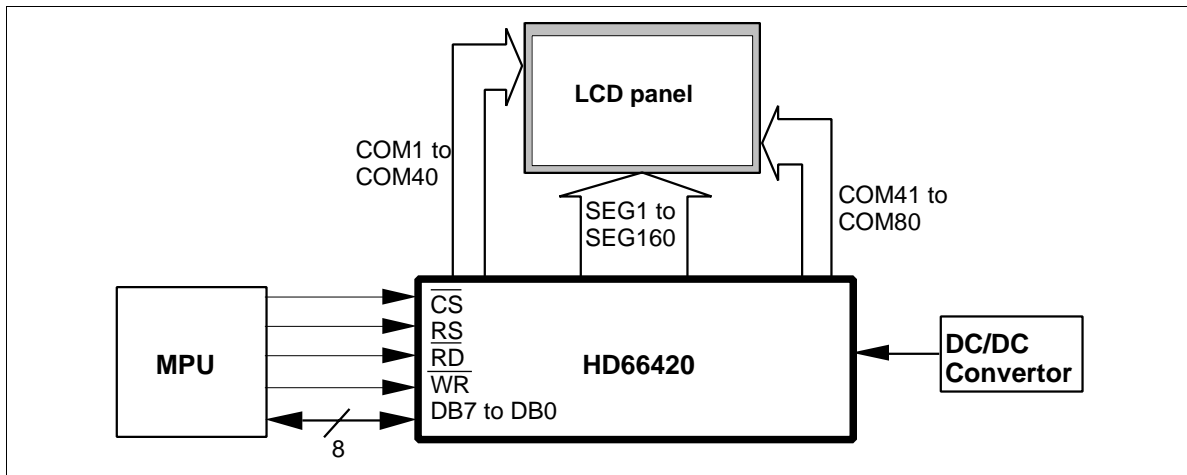

Figure 1 System Block Diagram

HD66420

MPU Interface

The HD66420 can interface directly to an MPU through an 8-bit data bus or through an I/O port (figure 2). The MPU can access the HD66420 internal registers independently of internal clock timing.

The index register can be directly accessed but the other registers (data registers) cannot. Before accessing a data register, its register number must be written to the index register. Once written, the register number is held until it is rewritten, enabling the same register to be consecutively accessed without having to rewrite to the register number for each access. An example of a register access sequence is shown in figure 3.

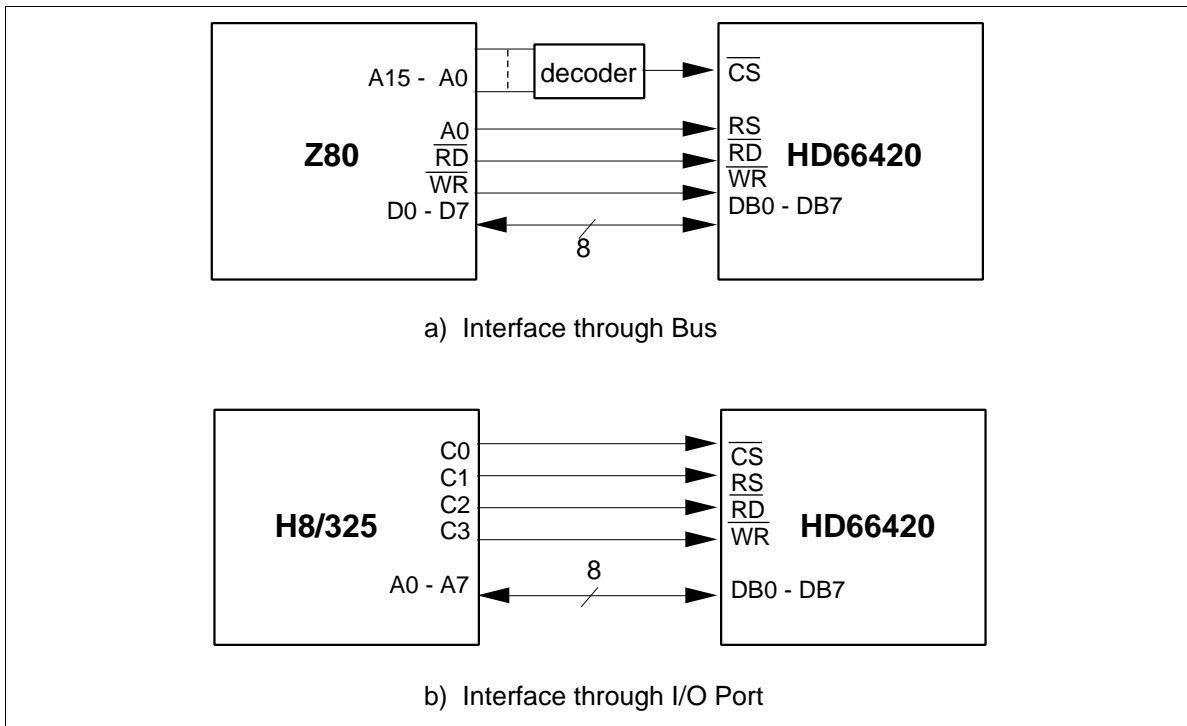

Figure 2 8-Bit MPU Interface Examples

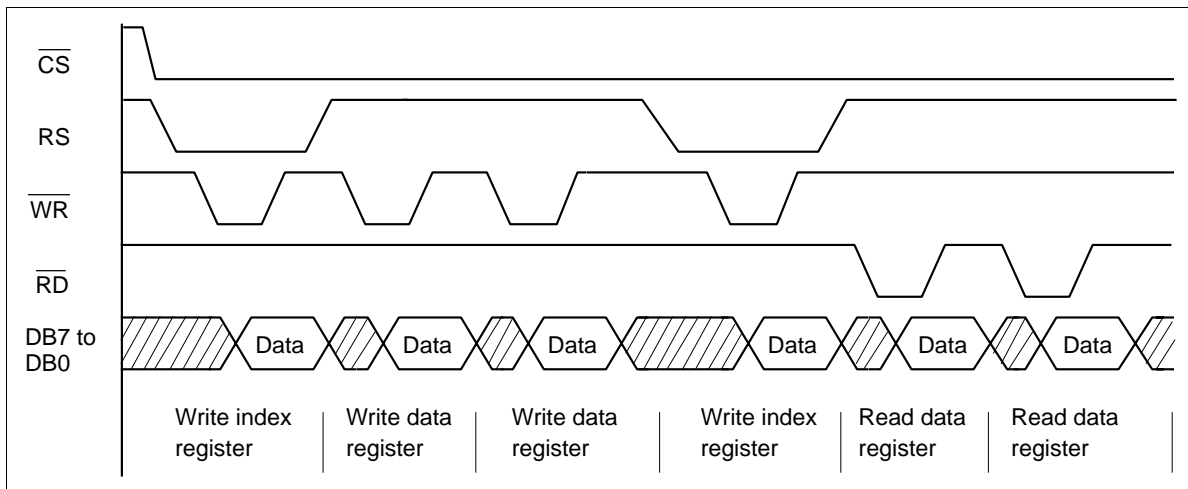

Figure 3 8-Bit Data Transfer Sequence

HD66420

LCD Driver Configuration

Row and column outputs: The HD66420 outputs row signals from both sides. In any case, each output's function is fixed; COM1 to COM80 output row signals and SEG1 to SEG160 output column signals.

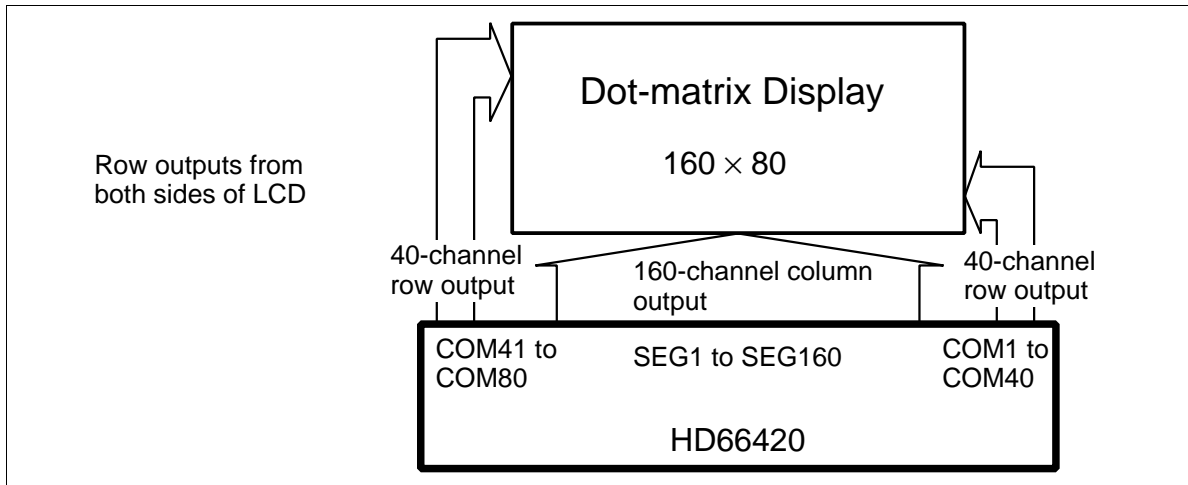

Figure 4 Common outputs from both sides

Column Address Inversion According to LCD Driver Layout: The HD6420 can always display data in address H'0 on the top left of an LCD panel regardless of where it is positioned with respect to the panel. This is because the HD66420 can invert the positional relationship between display RAM addresses and LCD driver output pins by inverting RAM addresses. Specifically, the HD66420 outputs data in address H'0 from SEG1 when the ADC bit in control register 1 is 0, and from SEG160 otherwise. Here, the scan direction of row output is also inverted according to the situation as shown in figure 6. Note that addresses and scan direction are inverted when data is written to the display RAM, and thus changing the ADC bit after data has been written has no effect. Therefore, hardware control bits such as ADC must be set immediately after reset is canceled, and must not be set while data is being displayed.

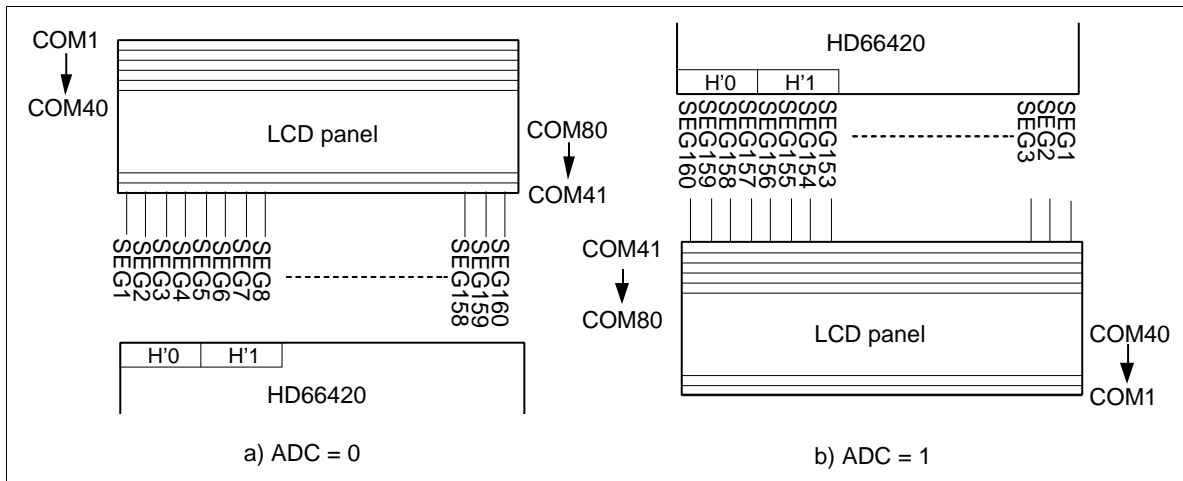

Figure 5 LCD Driver Layout and RAM addresses : 1/80 Duty cycle

Table 1 Scanning Direction and RAM Address

DTY1	DTY0	ADC	COMMON	SEGMENT
0	0	0	COM1 → COM40, COM80 → COM41	H'00 → SEG1
		1	COM41 → COM80, COM40 → COM1	H'00 → SEG160
	1	0	COM1 → COM32, COM80 → COM49	H'00 → SEG1
		1	COM49 → COM80, COM32 → COM1	H'00 → SEG160
1	0	0	COM1 → COM16, COM80 → COM65	H'00 → SEG1
		1	COM65 → COM80, COM16 → COM1	H'00 → SEG160
	1	0	8 COM depend on R11	H'00 → SEG1
		1	8 COM depend on R11	H'00 → SEG160

HD66420

Multi-LSI Operation

Using multiple HD66420s provides the means for extending the number of display dots. Note the following items when using the multi-LSI operation.

- (1) The master LSI and the slave LSI must be determined; the M/S pin of the master LSI must be set high and the M/S pin of the slave LSI must be set low.
- (2) The master LSI supplies the FLM, M, CL1 and clock signals to the slave LSI via the corresponding pins, which synchronizes the slave LSI with the master LSI.
- (3) All control bits of slave LSI must be set with the same data with that of the master LSI.
- (4) All LSIs must be set to LCD off in order to turn off the display.
- (5) The standby function of slave LSI must be started up first, and that of the master LSI must be terminated first.
- (6) The power supply circuit of slave LSI stop working, so V1 to V5 levels are supplied from the master LSI. If the internal power supply circuit can not drive two LSIs, use an external power supply circuit.

Figure 6 shows the configuration using two HD66420s and table 2 lists the differences between master and slave modes.

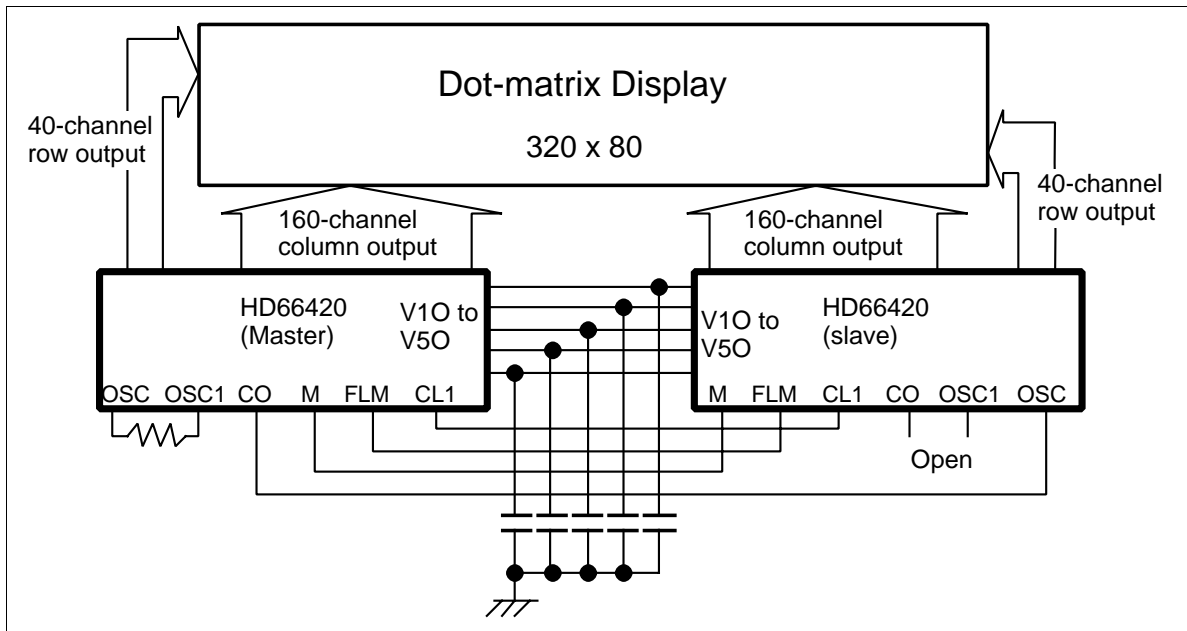

Figure 6 Configuration Using Two HD66420s

Table 2 Comparison between Master and Slave Modes

Item		Master Mode	Slave Mode
Pin	M/S	Must be set high	Must be set low
	OSC	Oscillation is active	Oscillation is active
	CO	Output	High-Z
	FLM, M, CL1	Output signals	Input signals
Registers	R0, R2 to R15	Valid	Valid
	R1: BIS1, 0	Valid	Invalid
	R1: other	Valid	Valid
	R16	Valid	Invalid
Power supply circuit		Valid	Invalid

HD66420

Display RAM Configuration and Display

The HD66420 incorporates a bit-mapped display RAM. It has 320 bits in the X direction and 80 bits in the Y direction. The 320 bits are divided into forty 8-bit groups. As shown in figure 6, data written by the MPU is stored horizontally with the MSB at the far left and the LSB at the far right. The consecutive two bits control one pixel of LCD, this means that one 8-bit data contains data which controls four pixels.

The ADC bit of control register 1 can control the positional relationship between X addresses of the RAM and LCD driver output (figure 7). Specifically, the data in address H'0 is output from SEG1 when the ADC bit in control register 1 is 0, and from SEG160 otherwise. Here, data in each 8-bit group is also inverted. Because of this function, the data in X address H'0 can be always displayed on the top left of an LCD panel with the MSB at the far left regardless of the LSI is positioned with respect to the panel. In this case, DB7, DB5, DB3 and DB1 are more significant bit in consecutive two bits.

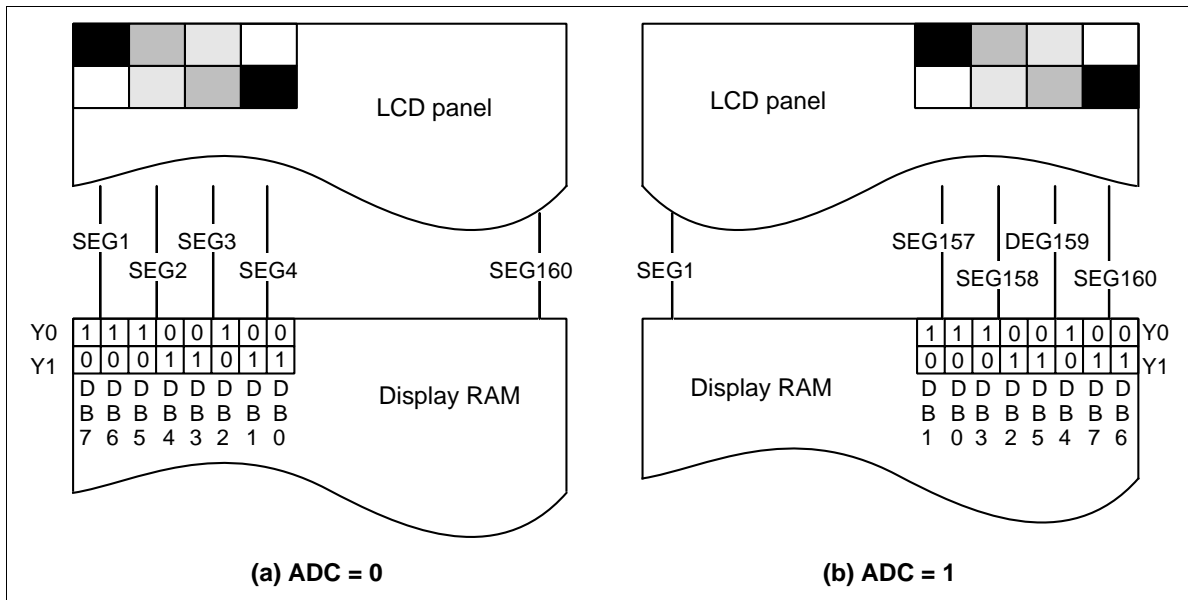

Figure 7 Display RAM Data and Display

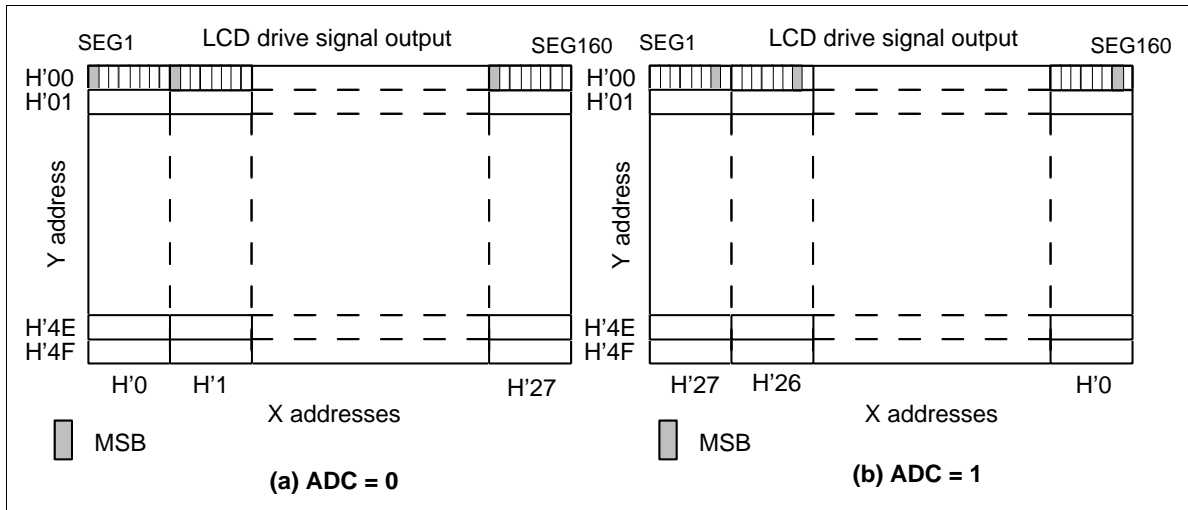

Figure 8 Display RAM Configuration

HD66420

Word Length

The HD66420 can handle either 8- or 6-bits as a word. In the display memory, one X address is assigned to each word of 8- or 6-bits long in X direction.

When the 6-bits mode is selected, only data on DB5 to DB0 are used and data on DB7 and DB6 are discarded. This word length is only applied to data to internal RAM. The word length of internal register is always 8-bits

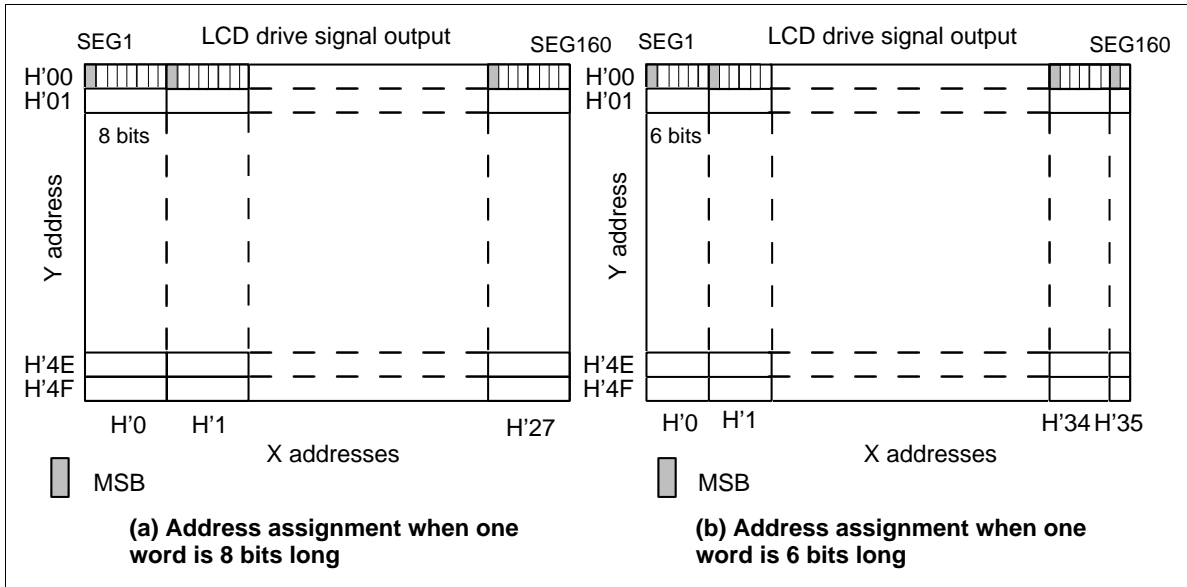

Figure 9 Display RAM Addresses

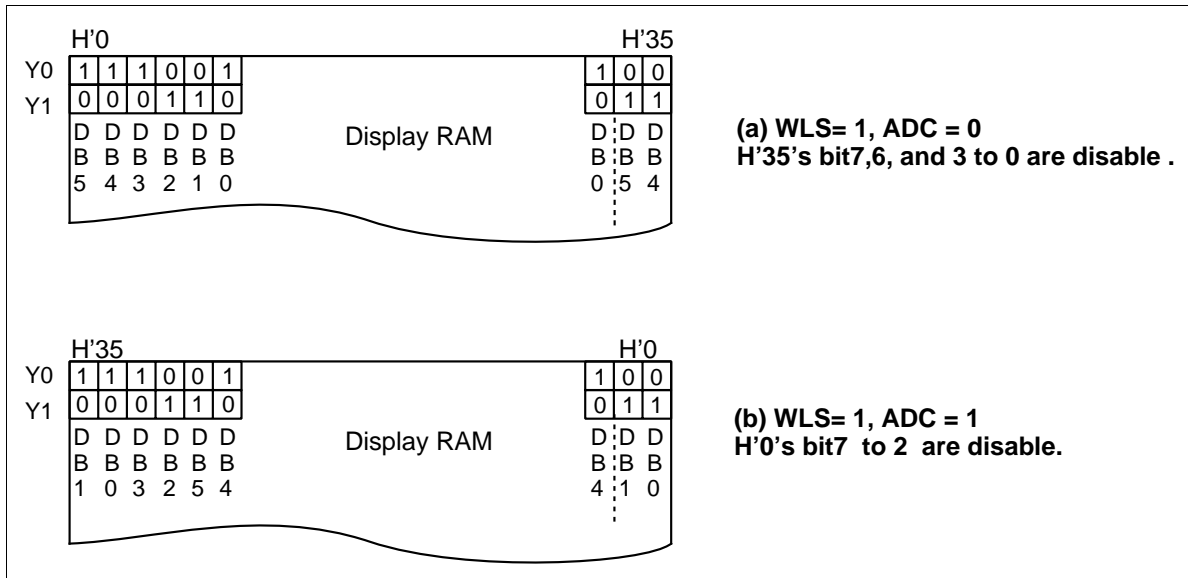

Figure 10 Display RAM Bits Map

HD66420

Configuration of Display Data Bit

Packed Pixel Method

For grey scale display and super reflective colour display, multiple bits are needed for one pixel. In the HD66420, two bits are assigned to one pixel, enabling a four-level grey scale display and four colour display.

One address, eight bits, specifies four pixels, and pixel bits 0 and 1 for gray scale are managed as consecutive bits in one byte.

When grey scale display data is manipulated in bit units, one memory access is sufficient, which enables smooth high-speed data rewriting.

The bit data to input to pin DB7, DB5, DB3 and DB1 become MSB and the bit data to input via pin DB6, DB4, DB2 and DB0 are LSB.

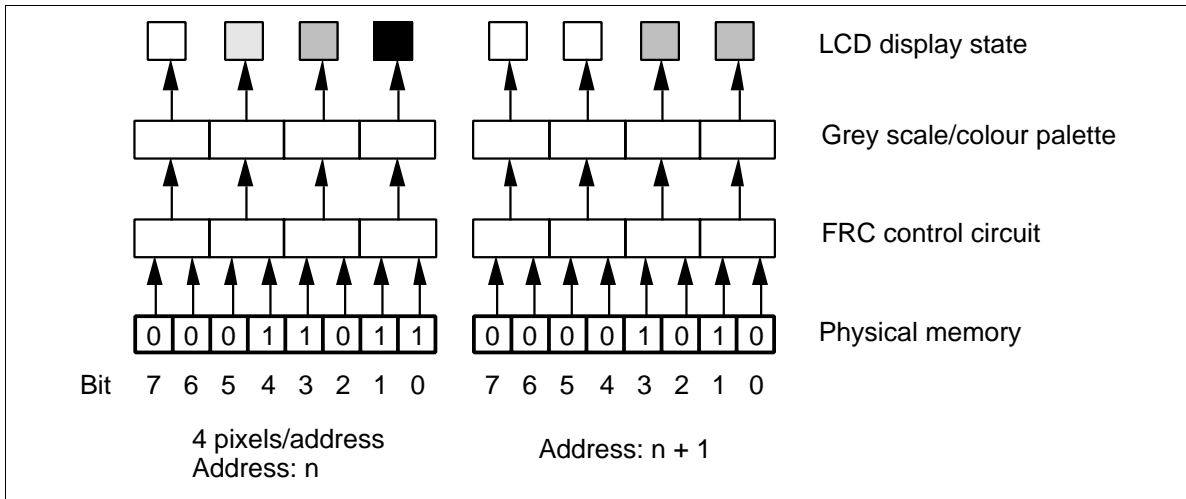

Figure 11 Packed Pixel Method

Gray scale/Colour palette

The HD66420 uses PWM, Pulse Width Modulation, technique for gray scale display. A period of one line is divided into thirty-one or four and HD66420 outputs turn-on levels for one period and turn-off levels for rest of these period. This technique changes gray scale on monochrome display and colour on super reflective colour panel. The characteristics of these panel vary with different panel. To allow for this, the HD66420 designed to generate 32-levels gray scale levels and provides palette registers that assign desired levels to certain of the four colours, GRAY = 0, or generate dedicated 4-level grayscale , GRAY = 1. Using the palette registers to select any 4 out of 32 levels of applied voltages enables an optimal grayscale/colour display. Because of this grayscale technique using 32-levels gray scale needs higher clock rate. If 32-levels gray scale is not needed, lower clock rate can be used. Table 3 shows default value of palette registers and Table 4 and 5 show relationship between value of a palette register and grayscale level.

Table 3 Default Value of Palette Registers

DB7, 5, 3, 1	DB6, 4, 2, 0	Register Name	Default Value				
0	0	Grayscale Palette 1	0	0	0	0	0
	1	Grayscale Palette 2	0	1	0	1	1
1	0	Grayscale Palette 3	1	0	1	1	1
	1	Grayscale Palette 4	1	1	1	1	1

HD66420

Table 4 Value of a Palette Register and Grayscale Levels (GRAY= 0)

Value					Grayscale Level	
0	0	0	0	0	0	default R12
				1	1/31	
		1	0	0	2/31	
				1	3/31	
	1	0	0	0	4/31	
				1	5/31	
		1	0	0	6/31	
				1	7/31	
	1	0	0	0	8/31	
				1	9/31	
		1	0	0	10/31	
				1	11/31	default R13
	1	0	0	0	12/31	
				1	13/31	
		1	0	0	14/31	
				1	15/31	
1	0	0	0	0	16/31	
				1	17/31	
		1	0	0	18/31	
				1	19/31	
	1	0	0	0	20/31	
				1	21/31	
		1	0	0	22/31	
				1	23/31	default R14
	1	0	0	0	24/31	
				1	25/31	
		1	0	0	26/31	
				1	27/31	
	1	0	0	0	28/31	
				1	29/31	
		1	0	0	30/31	
				1	1	default R15

Table 5 Grayscale Levels (GRAY= 1)

DB7, 5, 3, 1	DB6, 4, 2, 0	Grayscale Level
0	0	0
	1	1/3
1	0	2/3
	1	1

Access to Internal Registers and Display RAM

Access to Internal Registers by the MPU: The internal registers include the index register and data registers. The index register can be accessed by driving both the CS and RS signals low. To access a data register, first write its register number ID to the index register with RS set to 0, and then access the data register with RS set to 1. Once written, the register number is held until it is rewritten, enabling the same register to be consecutively accessed without having to rewrite to the register number for each access. Some data registers contain unused bits; they should be set to 0. Note that all data registers except the display memory access register can only be written to.

Access to Display RAM by the MPU: To access the display RAM, first write the RAM address desired to the X address register (R2) and the Y address register (R3). Then read/write the display memory access register (R4). Memory access by the MPU is independent of memory read by the HD66420 and is also asynchronous with the HD66420's clock, thus enabling an interface independent of HD66420's internal operations.

However, when reading, data is temporarily latched into a HD66420's buffer and then output next time, a read is performed in a subsequent cycle. This means that a dummy read is necessary after setting X and Y addresses. The memory read sequence is shown in figure 12.

X and Y addresses are automatically incremented after each memory access according to the INC bit value in control register 2; therefore, it is not necessary to update the addresses for each access. Figure 13 shows two cases of incrementing display RAM address. When the INC bit is 0, the Y address will be incremented up to H'7F with the X address unchanged. However, actual memory is valid only within H'00_ to H'4F; accessing an invalid address is ignored. When the INC bit is 1, the X address will be incremented up to H'27 or H'35 according to WLS bit with the Y address unchanged. After address H'27 or H'35, the X address will be returned to H'00; accessing more than forty bytes causes rewriting to the same address.

HD66420

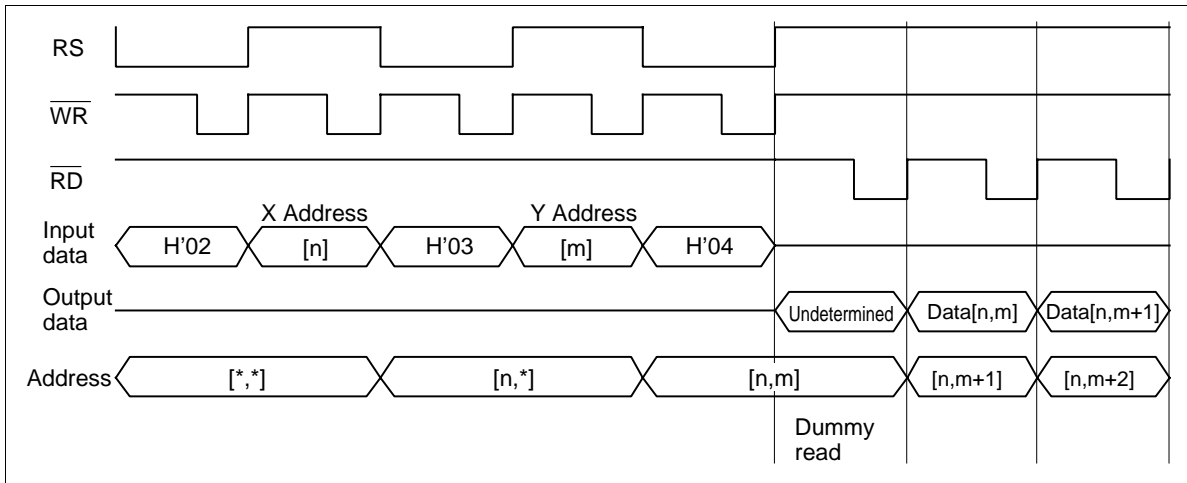

Figure 12 Display RAM read sequence

Display RAM Reading by LCD Controller:

Data is read by the HD66420 to be displayed asynchronously with accesses by the MPU. However, because simultaneous access could damage data in the display RAM, the HD66420 internally arbitrates access timing; access by the MPU usually has priority and so access by the HD66420 is placed between accesses by the MPU. Accordingly, an appropriate time must be secured (see the given electrical characteristics between two accesses by the MPU).

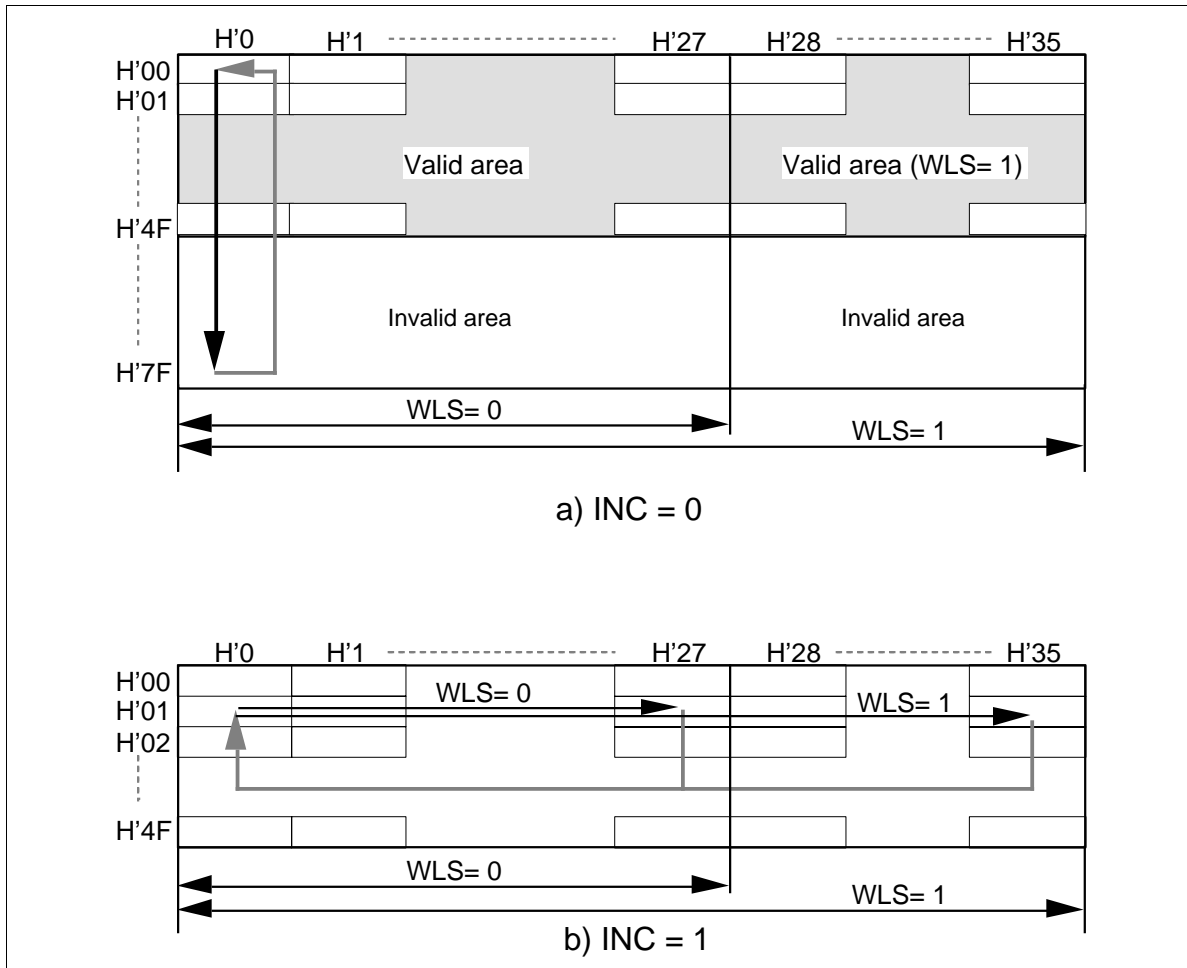

Figure 13 Display Address Increment

HD66420

Read-Modify-Write: X- or Y-address is incremented after reading form or writing data to the display RAM at normal mode. However, X- or Y-address is not incremented after reading data from the display RAM at read-modify-write mode. The data which is read from the display RAM may be modified and written to the same address without re-setting the address. Data is temporarily latched into a HD66420's buffer and then output next time a read is performed in a subsequent cycle. This means that the dummy read is necessary after every cycle. This sequence is shown in figure 14.

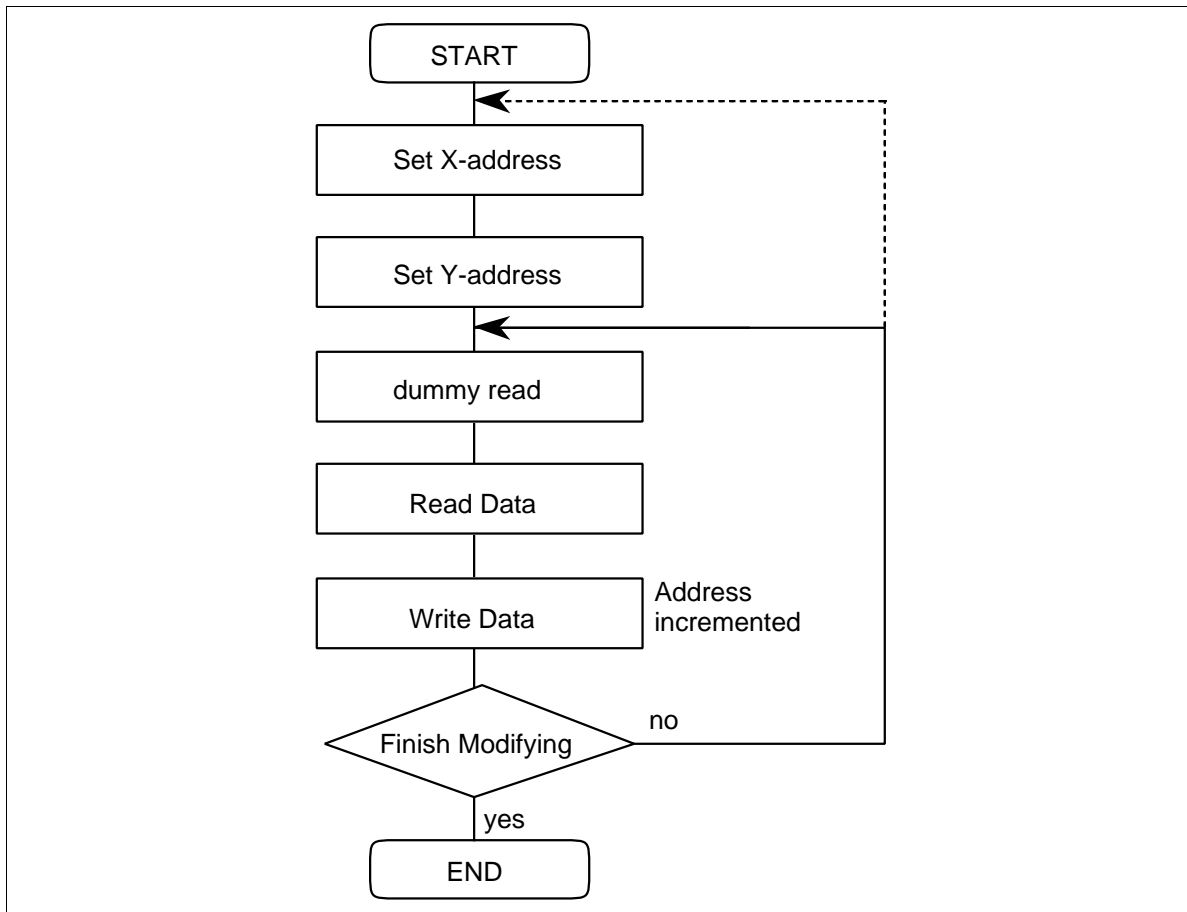

Figure 14 The Flow Chart for Read-Modify-Write

Vertical Scroll Function

The HD66420 can vertically scroll a display by varying the top raster to be displayed, which is specified by the display start raster register. Figure 15 and 16 show vertical scroll examples. As shown, when the top raster to be displayed is set to 1, data in Y address H'00_ is displayed on the 80th raster. To display another frame on the 80th raster, therefore, data in Y address H'00_ must be modified after setting the top raster. When display duty is less than 80, for example 1/64, data of address H'40 is displayed after address H'3F.

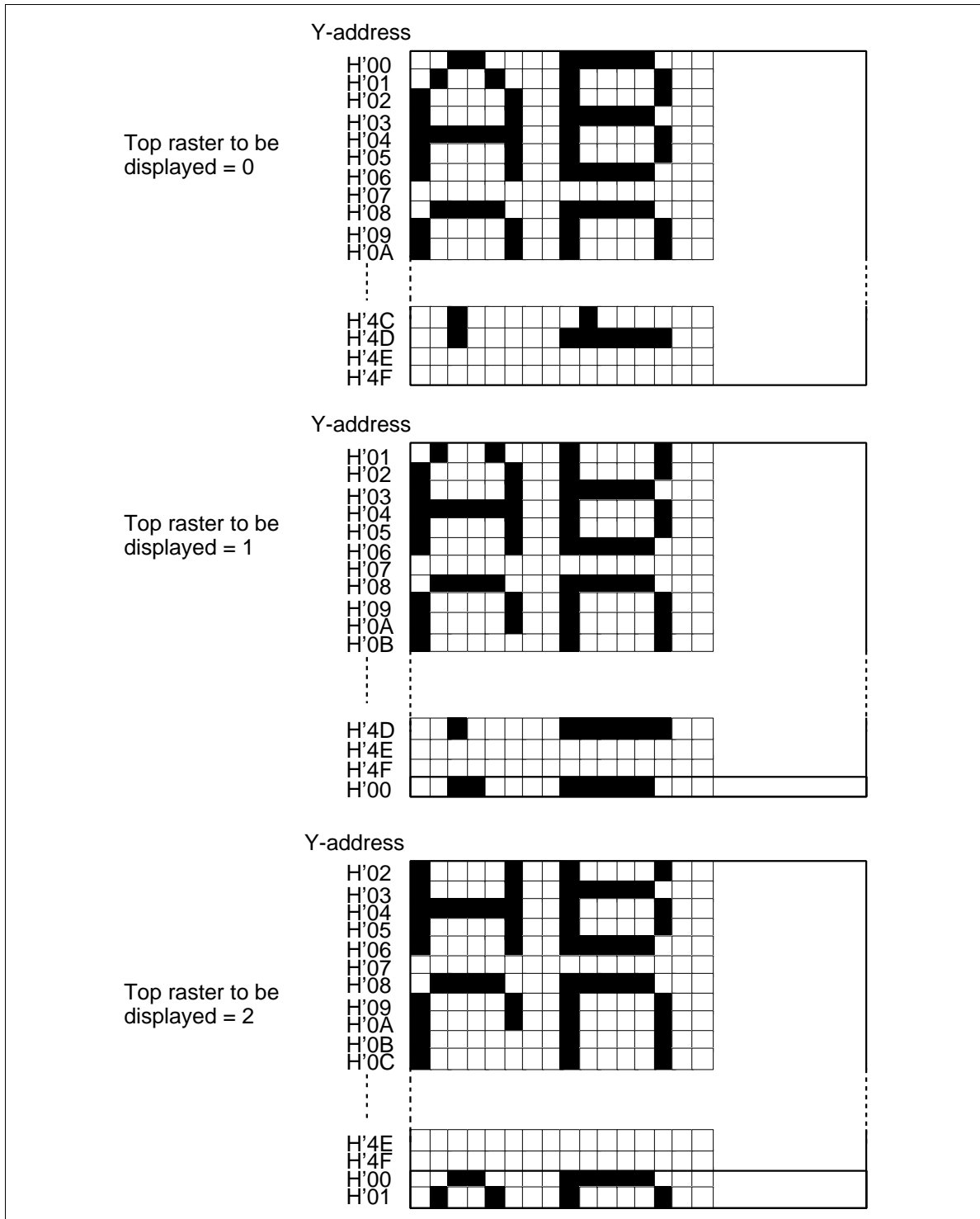

Figure 15 Vertical Scroll : 1/80Duty Cycle

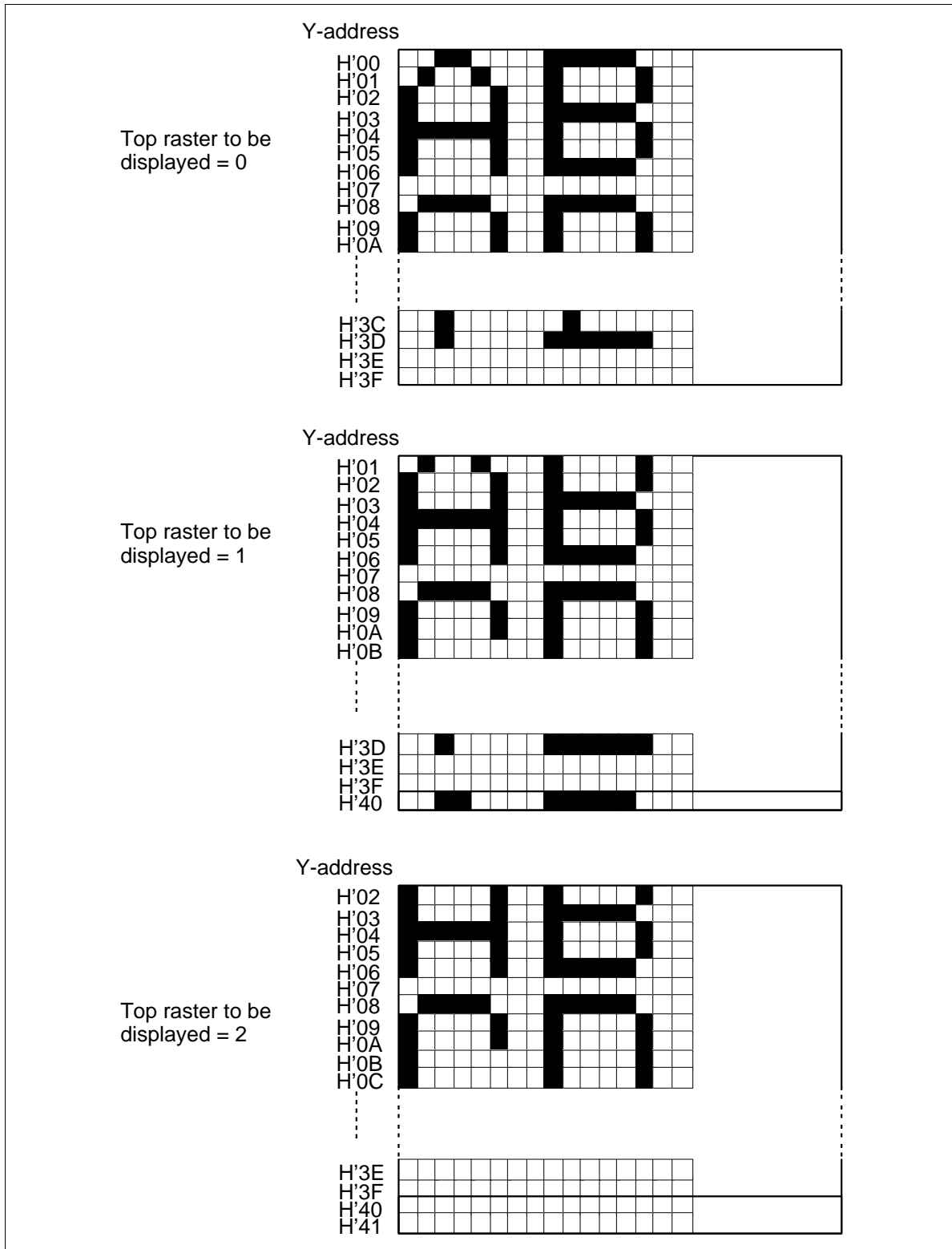

Figure 16 Vertical Scroll : 1/64Duty Cycle

HD66420

Partial Display Function

The HD66420 can display only a part of a full display. The bias ratio of this partial display is 1/4 from V_{CC} to GND, the duty ratio is 1/8 and rest of display is scanned with unselected levels. 8 levels of contrast can be selected with data bit 2 to 0 of R16. The position of this partial display can be located at any position with using partial display position register. To launch this mode, following processes are needed:

- (1) supplied voltage to VLCD must be cut off, PWR bit can be used if external voltage supplier is controlled with DCON output (R0)
- (2) set DTY0, 1 bits (R1)
- (3) set COM scanning direction (ADC bit)
- (4) set display position (R11, R5)
- (5) set contrast level (R16 data-bit 2 to 0)

The clock frequency may be 180kHz at normal display mode. When a partial display is driven, oscillation frequency will be 18kHz, 1/10 of that of normal display mode. This function is useful for lower power dissipation. To change clock frequency, follow the process which is showed in Figure 21.

Warning: VLCD must be cut off when partial display mode is launched. Vcc is supplied to LCD driving circuit instead of VLCD. So if VLCD is supplied externally during partial display mode, Vcc short-circuit to VLCD.

Table 6 Partial Display Block

R11	ADC = 1	ADC = 0
H'00	COM1 → COM8	COM8 → COM1
H'01	COM9 → COM16	COM16 → COM9
H'02	COM17 → COM24	COM24 → COM17
H'03	COM25 → COM32	COM32 → COM25
H'04	COM33 → COM40	COM40 → COM33
H'05	COM80 → COM73	COM73 → COM80
H'06	COM72 → COM65	COM65 → COM72
H'07	COM64 → COM57	COM57 → COM64
H'08	COM56 → COM49	COM49 → COM56
H'09	COM48 → COM41	COM41 → COM48

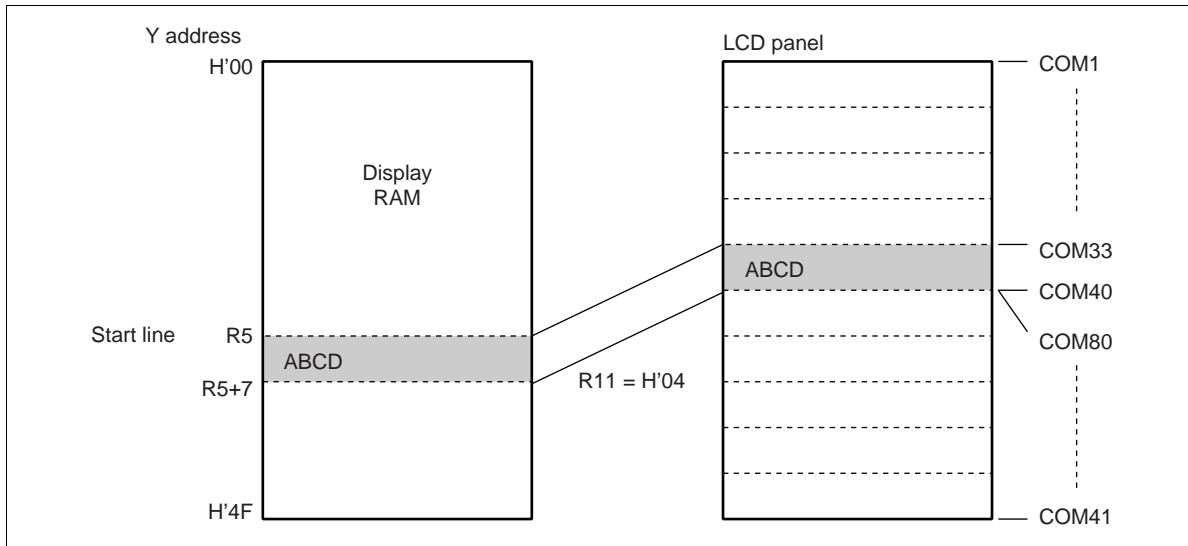

Figure 17 Partial Display

HD66420

Blink Function

The HD66420 can blink a specified area on the dot-matrix display. Blinking is achieved by repeatedly turning on and off the specified area at a frequency of one sixty-fourth the frame frequency. For example, when the frame frequency is 80 Hz, the area is turned on and off every 0.8 seconds.

The area to be blinked can be designated by specifying vertical and horizontal positions of the area. The vertical position or the rasters to be blinked, are specified by the blink start raster register (R6) and blink end raster register (R7).

The horizontal position, or the dots to be blinked in the specified rasters, are specified by the blink registers R8, R9 and R10 in an 8-dot group; each data bit in the blink registers controls its corresponding 8-dots group. The relationship between the registers and blink area is shown in figure 18. Setting the BLK bit to 1 in control register 2 after setting the above registers starts blinking the designated area. Note that since the area to be blinked is designated absolutely with respect to the display RAM, it will move along with a scrolling display (figure 19).

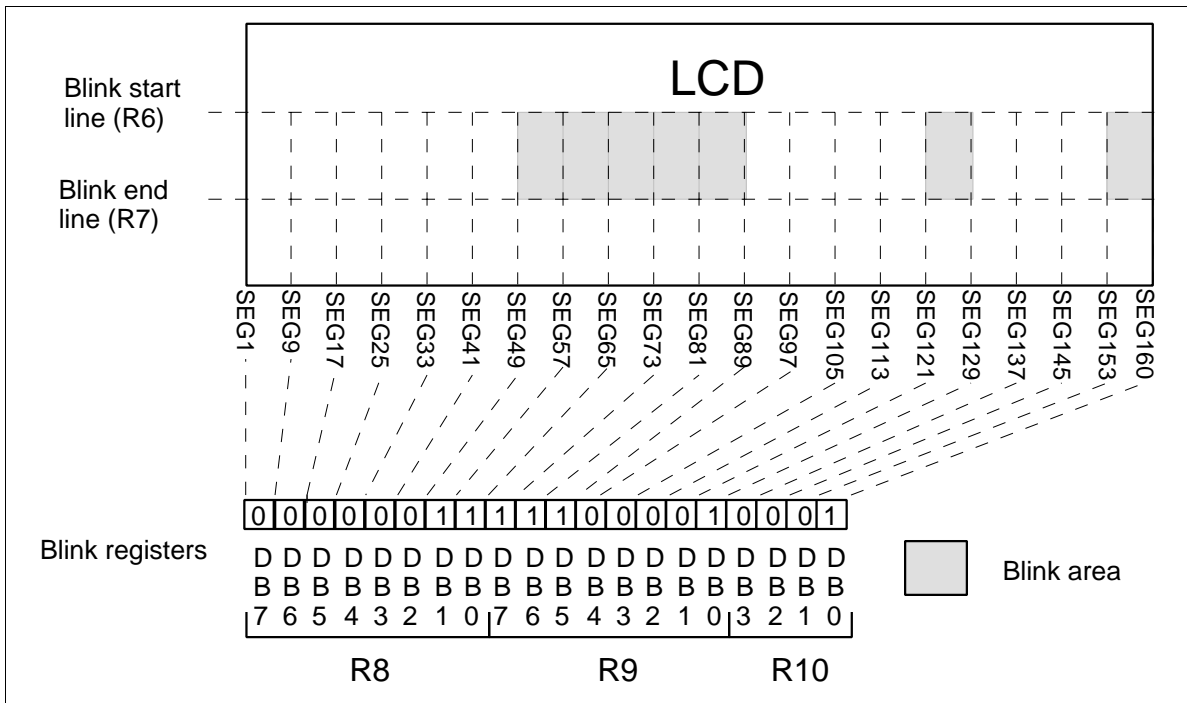

Figure 18 Blink Area Designation by Blink Control Registers

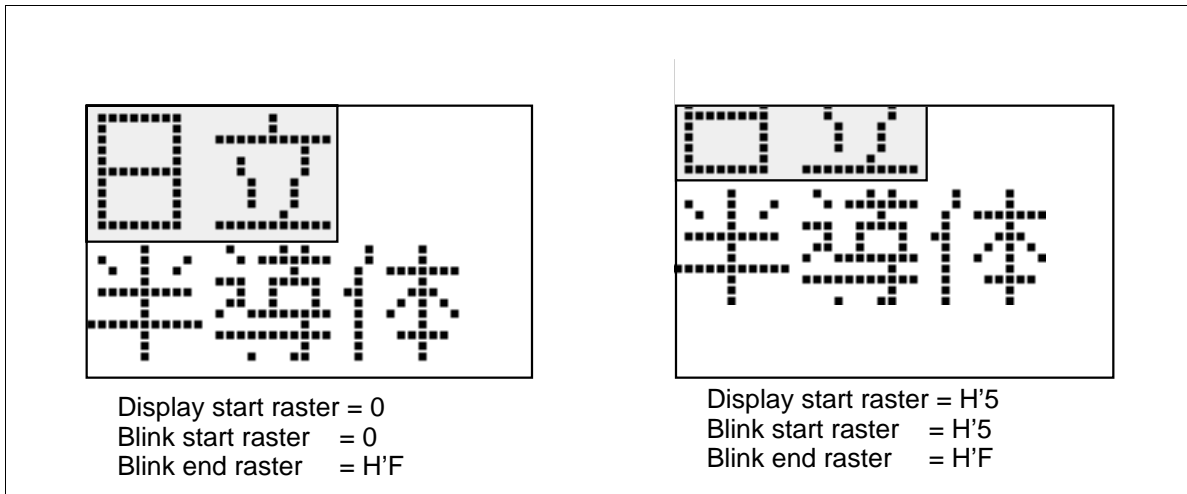

Figure 19 Scrolling Blink Area

HD66420

Power Down Modes

The HD66420 has a standby function providing low power-dissipation, which is initiated by internal register settings. During standby mode, all the HD66420 functions are inactive and data in the display RAM and internal registers except the DISP bit are retained. However, only control registers can be accessed during standby mode. HD66420 has another power down mode: partial display. In this mode only a part of display is active. However, this duty ratio is 1/8 so the external power supply for LCD drive will be inactive. The oscillator does not halt, thus dissipating more power than standby mode. Table 7 lists the LCD driver output pin status during standby mode. Figure 20 shows the procedure for initiating and canceling a standby mode and figure 21 shows the procedure for changing oscillator. Note that these procedure must be strictly followed to protect data in the display RAM.

Table 7 Output Pin Status during Power Down modes

Signal Name	STBY	Status
COM1–COM80	1	Output VLCD (display off)
	0	Output common signals (VLCD–GND)
SEG1–SEG160	1	Output VLCD (display off)
	0	Output segment signals (VLCD–GND)

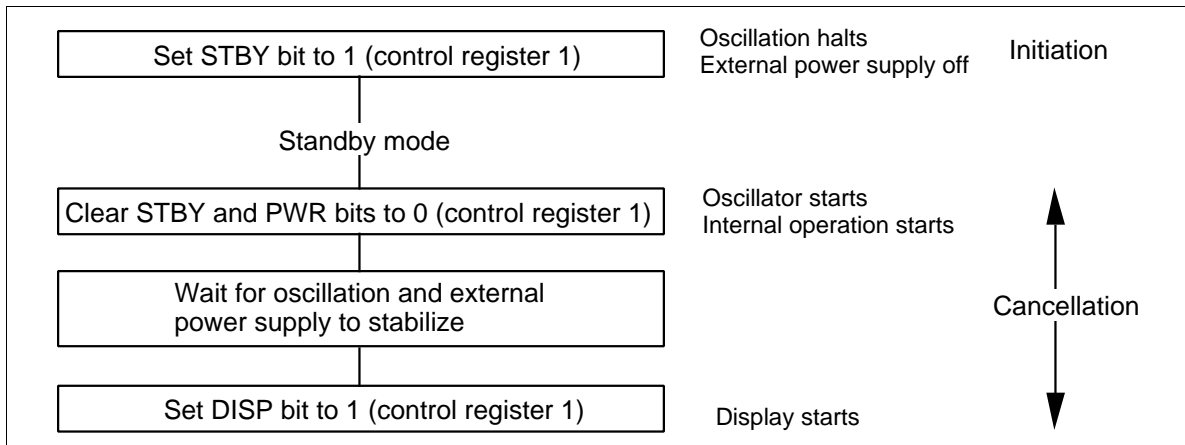

Figure 20 Procedure for Initiation and Canceling a Standby Mode

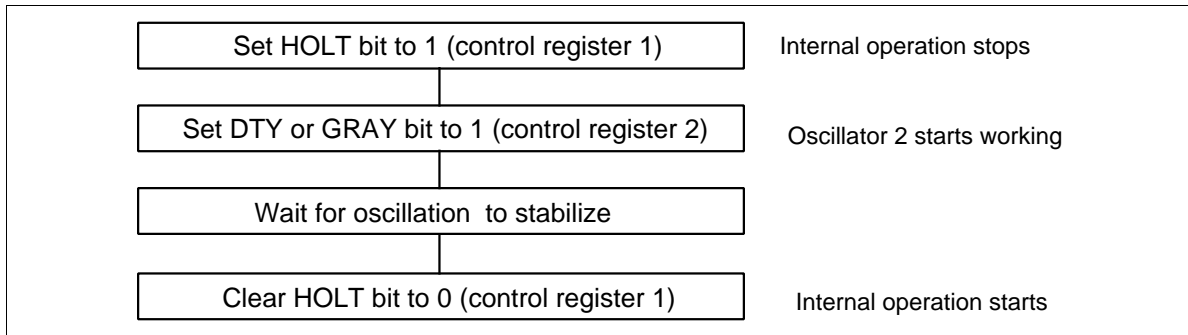

Figure 21 Procedure for Changing Oscillator

Power On/Off Procedure

Figure 22 shows the procedure for turning the power supply on and off. This procedure must be strictly followed to prevent incorrect display because the HD66420 incorporates a power supply circuit.

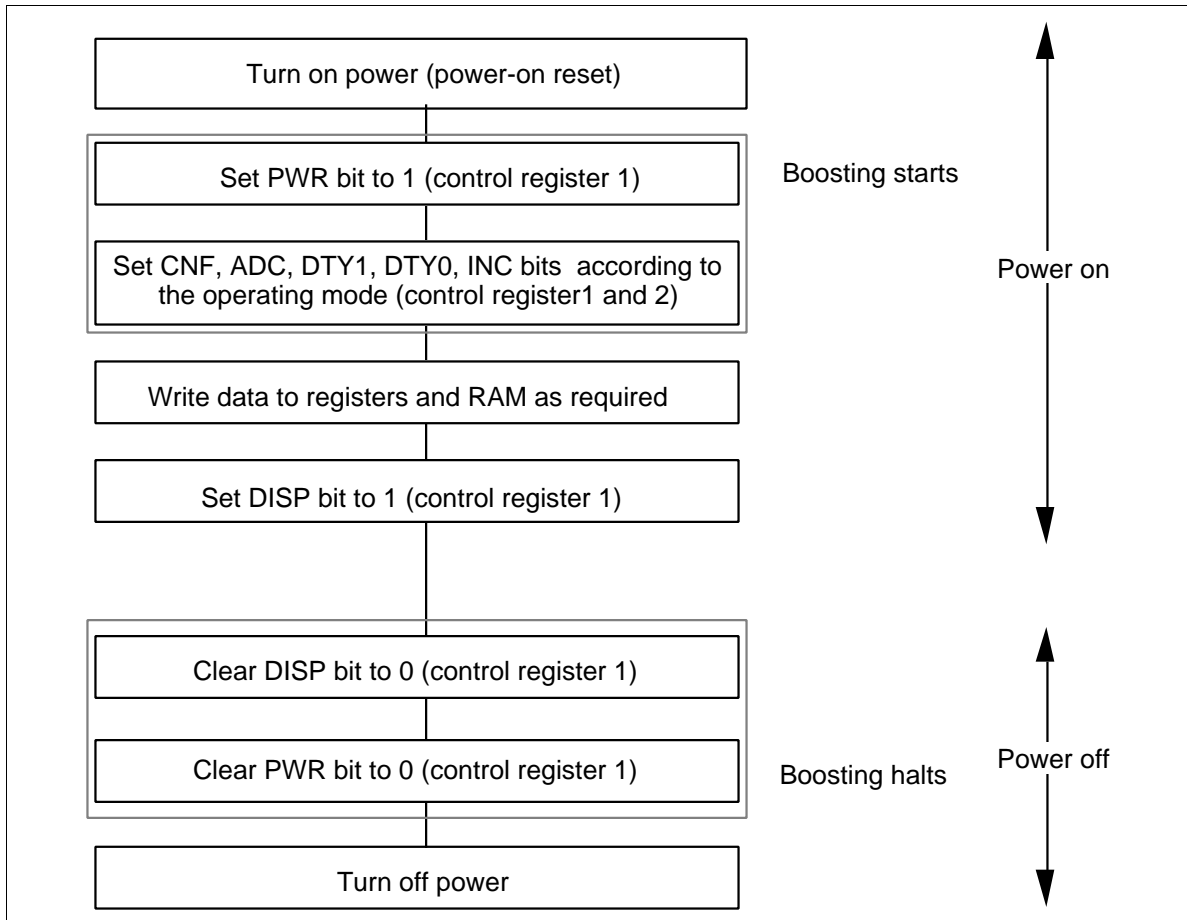

Figure 22 Procedure for Turning Power Supply On/Off

Oscillator

The HD66420 incorporates two sets of R-C oscillator for two display modes: OSC-OSC1 oscillator is used for 32-levels gray scale display mode and OSC-OSC2 oscillator for 4-levels gray scale display mode. If the internal oscillator is not used, an appropriate clock signal must be externally input through the OSC pin. In this case, the OSC1 and OSC2 pins must be left unconnected. Oscillation resistor must be placed near LSI, because if capacitance exists between OSC and OSC1 oscillator may not work properly. Figure 23 shows oscillator connections.

Changing Oscillator

Two oscillators are alternated automatically depending on modes. The resistor between OSC and OSC1 is used during 32-levels grayscale mode and the resistor between OSC and OSC2 is used during 4-levels grayscale mode. An external clock must be input from OSC terminal at any modes.

Clock and Frame Frequency

The HD66420 generates the frame frequency by dividing the input clock. Clock frequency is determined with following equation:

$$f_{osc} = N * (\text{Duty ratio}) * (\text{Frame frequency})$$

N: 31 for 32-level gray scale display mode

3 for 4-level gray scale display mode

The frame frequency is usually 70 to 90 Hz; when the frame frequency is 70 Hz, for example, the input clock frequency will be 180 kHz for 32-level gray scale display mode, and 18kHz for 4-level gray scale.

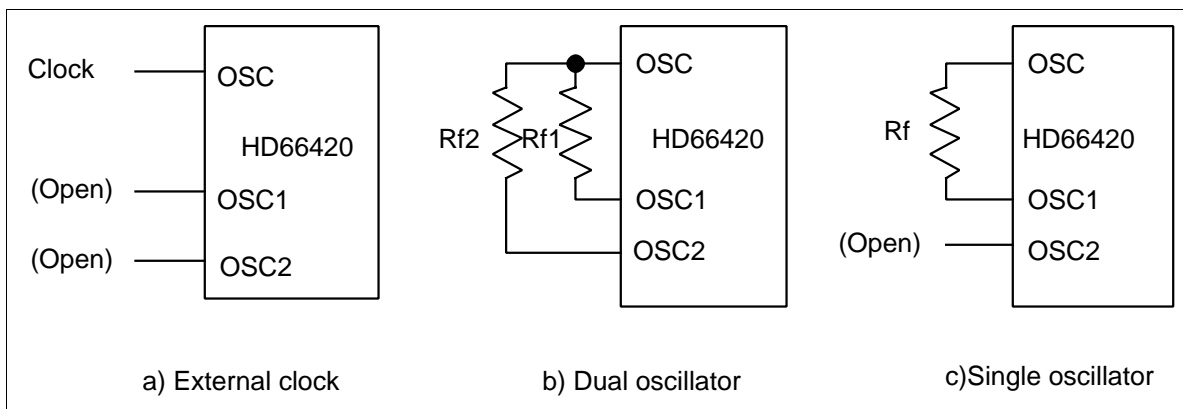

Figure 23 Oscillator Connections

HD66420

Power Supply Circuits

HD66420 has following circuits for power supply circuit: operational amplifiers, resistive dividers, bias control circuit and contrast control circuit. LCD driving voltage, VLCD, must be generated externally.

LCD Drive Voltage Power Supply Levels: To drive the LCD, a 6-level power supply is necessary. These levels are generated internally or supplied from outside. When an internal voltage levels generator is chosen, external capacitors are needed to stabilize these levels. AS the HD66420 incorporates operational amplifiers to these levels, this circuit gives better quality of display with less power consumption. This divided ratio is programmable.

Bias current of internal operational amplifier is determined with a resistor which is inserted between IREFM and GND. This resistor value is between 1M Ω and 5M Ω . Larger resistor value make less power consumption at internal operational amplifier. However, too large value loose operational margin of amplifiers.

Keep following relationship among voltage levels;

$$V_{CC} \geq IREFMP > IREFM \geq GND$$

$$VLCD > V_{CC} > GREF \geq GND$$

$$VLCD \geq V10 \geq V20 \geq V30 \geq V40 \geq V50 \geq GREF$$

$$VLCD - V_{CC} \geq 1.0V$$

$$IREFP - IREFM \geq 1.0V$$

$$V_{CC} - GREF \geq 1.0V$$

Contrast Control: Internal contrast control circuit can change the output voltage level of VLCD by setting data to contrast control register, R16. VLCD adjustable range are showed below;

- 1/6 bias
 $0.75 * (VLCD - GND) \leq VLCD \leq 0.99 * (VLCD - GND)$
- 1/9 bias
 $0.82 * (VLCD - GND) \leq VLCD \leq 0.993 * (VLCD - GND)$

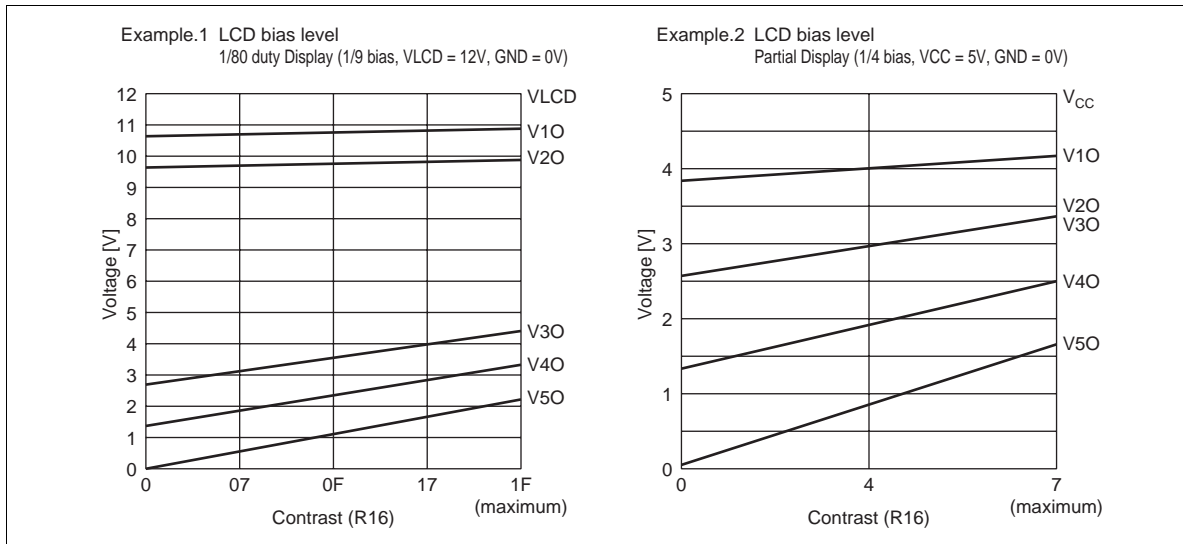

- Partial display

$$0.82 * (V_{CC}-GND) \leq V_{CC} \leq 0.997 (V_{CC}-GND)$$

Partial display function uses 1/4 bias ratio from V_{CC} to GND. Eight levels of contrast can be selected with data bit 2 to 0 of R16.

LCD drive levels bias ratio: LCD driving levels bias ratio can be selected from 1/6, 1/7, 1/8 or 1/9.

Power Supply: The HD66420 needs the external power supply for LCD driving circuit. If this power circuit has on/off control, the HD66420 controls the external power supply circuit by setting PWR bit.

External Power Supply Circuit: When the internal operational amplifier cannot fully drive the LCD panel used, V10 to V50 voltages can be supplied from external power supply circuit. Here, the AMP bit must be set to 1 to turn off the internal power supply circuit.

HD66420

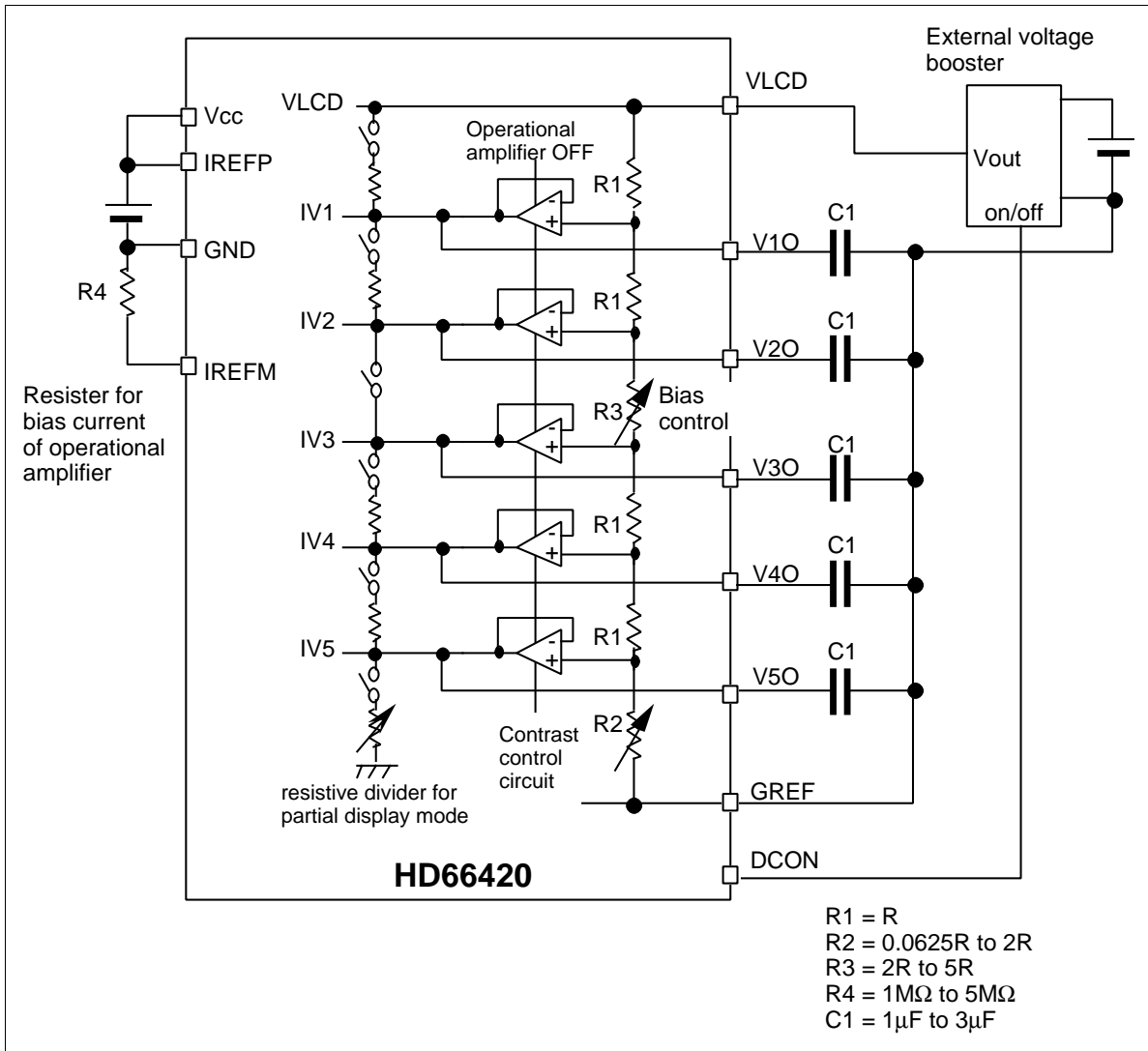

Figure 24 Power Supply Circuit

Reset

The low $\overline{\text{RES}}$ signal initializes the HD66420, clearing all the bits in the internal registers. During reset, the internal registers cannot be accessed.

Note that if the reset conditions specified in the Electric Characteristics section are not satisfied, the HD66420 will not be correctly initialized. In this case, the internal registers of the HD66420 must be initialized by software.

Initial Setting of Internal Registers: All the internal register bits are cleared to 0. Details are listed below.

- Normal operation
- Oscillator is active; OSC-OSC1 is used
- Display is off
- Y address of display RAM is incremented
- 1/80 duty cycle
- X and Y addresses are 0
- Data in address H'0 is output from the SEG1 pin
- Blink function is inactive
- Operational amplifier is disabled

Initial Setting of Pins:

Bus interface pins

During reset, the bus interface pins do not accept signals to access internal registers; data is undefined when read.

LCD driver output pins

During reset, all the LCD driver output pins (SEG1 to SEG161, COM1 to COM80) output V_{cc} -level voltage, regardless of data value in the display RAM, turning off the LCD. Here, the output voltage is not alternated. Note that the same voltage (VLCD) is applied to both column and row output pins to prevent liquid crystals from degrading.

Internal Registers

The HD66420 has one index register and 17 data registers, all of which can be accessed asynchronously with the internal clock. All the registers except the display memory access register are write-only. Accessing unused bits or addresses affects nothing; unused bits should be set to 0 when written to.

Index Register (IR): The index register (figure 25) selects one of 17 data registers. The index register itself is selected when both the $\overline{\text{CS}}$ and $\overline{\text{RS}}$ signals are low. Data bits 7 to 5 are unused; they should be set to 0 when written to.

HD66420

Control Register 1 (R0): Control register 1 (figure 26) controls general operations of the HD66420. Each bit has its own function as described below.

RMW bit

RMW = 1: Read-modify-write mode Address is incremented only after write access

RMW = 0: Address is incremented after both write and read accesses

DISP bit

DISP = 1: Display on

DISP = 0: Display off (all LCD driver output pins output VLCD level)

STBY bit

STBY = 1: Internal operation and oscillation halt; display off

STBY = 0: Normal operation

PWR bit

PWR = 1: Output high level from DCON terminal

PWR = 0: Output low level from DCON terminal

This bit controls the external power supply for LCD driving outputs.

AMP bit

AMP = 1: OP amp enable

AMP = 0: OP amp disable

REV bit

REV = 1: Reverse display

REV = 0: Normal display

HOLT bit

HOLT = 1 : Internal operation stops

HOLT = 0: Internal operation starts

ADC bit

ADC = 1: Data in X address H'0 is output from SEG160; row signals depend on duty.

ADC = 0: Data in X address H'0 is output from SEG1; row signals are scanned from COM1.

Data bit	7	6	5	4	3	2	1	0
Set value				Register number				

Figure 25 Index Register (IR)

Data bit	7	6	5	4	3	2	1	0
Set value	RMW	DISP	STBY	PWR	AMP	REV	HOLT	ADC

Figure 26 Control Register 1 (R0)

Control Register 2 (R1): Control register 2 (figure 27) controls general operations of the HD66420. Each bit has its own function as described below.

BIS1, BIS0 bits

BIS1, 0 = (1, 1): 1/6 LCD drive levels bias ratio

BIS1, 0 = (1, 0): 1/7 LCD drive levels bias ratio

BIS1, 0 = (0, 1): 1/8 LCD drive levels bias ratio

BIS1, 0 = (0, 0): 1/9 LCD drive levels bias ratio

WLS bit

WLS = 1: A word length is 6-bits

WLS = 0: A word length is 8-bits

GRAY bit

GRAY = 1: 4-levels of gray scale are fixed

GRAY = 0: 4-levels of gray scale are selected from 32-levels

DTY1,DTY0 bits

DTY1, 0 = (1, 1): 1/8 display duty cycle; partial display mode

DTY1, 0 = (1, 0): 1/32 display duty cycle

DTY1, 0 = (0, 1): 1/64 display duty cycle

DTY1, 0 = (0, 0): 1/80 display duty cycle

INC bit

INC = 1: X address is incremented for each access

INC = 0: Y address is incremented for each access

BLK bit

BLK = 1: Blink function is used

BLK = 0: Blink function is not used

The blink counter is reset when the BLK bit is set to 0. It starts counting and at the same time initiates blinking when the BLK bit is set to 1.

X Address Register (R2): The X address register (figure 28) designates the X address of the display RAM to be accessed by the MPU. The set value must range from H'00 to H'27 in the case of 8-bit a word or range from H'00 to H'35 in the case of 6-bit a word; setting a greater value is ignored. The set address is automatically incremented each time the display RAM is accessed; it is not necessary to update the address each time. Data bits 7 and 6 are unused; they should be set to 0 when written to.

HD66420

Y Address Register (R3): The Y address register (figure 29) designates the Y address of the display RAM to be accessed by the MPU. The set value must range from H'00 to H'40; setting a greater value is ignored. The set address is automatically incremented each time the display RAM is accessed; it is not necessary to update the address each time. Data bit 7 is unused; it should be set to 0 when written to.

Data bit	7	6	5	4	3	2	1	0
Set value	BIS1	BIS0	WLS	GRAY	DTY1	DTY0	INC	BLK

Figure 27 Control Register 2 (R1)

Data bit	7	6	5	4	3	2	1	0
Set value			XA5	XA4	XA3	XA2	XA1	XA0

Figure 28 X address Register (R2)

Data bit	7	6	5	4	3	2	1	0
Set value		YA6	YA5	YA4	YA3	YA2	YA1	YA0

Figure 29 Y address Register (R3)

Display Memory Access Register (R4): The display memory access register (figure 30) is used to access the display RAM. If this register is write-accessed, data is directly written to the display RAM. If this register is read-accessed, data is first latched to this register from the display RAM and sent out to the data bus on the next read; therefore, a dummy read access is necessary after setting the display RAM address.

Display Start Raster Register (R5): The display start raster register (figure 31) designates the raster to be displayed at the top of the LCD panel. Varying the set value scrolls the display vertically.

The set value must be one less than the actual top raster and less than the duty ratio. If the value is set outside these ranges, data may not be displayed correctly. Data bit 7 is unused; they should be set to 0 when written to.

Blink Start Raster Register (R6): The blink start raster register (figure 32) designates the top raster in the area to be blinked. The set value must be one less than the actual top raster and less than the duty ratio. If the value is set outside these ranges, operations may not be correct. Data bit 7 is unused; they should be set to 0 when written to.

Blink End Raster Register (R7): The blink end register (figure 33) designates the bottom raster in the area to be blinked. The area to be blinked is designated by the blink registers, blink start raster register, and blink end raster register. The set value must be one less than the actual bottom raster and less than the duty ratio.

It must also be greater than the value set in the blink start raster register. If an inappropriate value is set, operations may not be correct. Data bit 7 is unused; they should be set to 0 when written to.

Data bit	7	6	5	4	3	2	1	0
Set value	D7	D6	D5	D4	D3	D2	D1	D0

Figure 30 Display Memory Access Register (R4)

Data bit	7	6	5	4	3	2	1	0
Set value		ST6	ST5	ST4	ST3	ST2	ST1	ST0

Figure 31 Display Start Raster register (R5)

Data bit	7	6	5	4	3	2	1	0
Set value		BSL6	BSL5	BSL4	BSL3	BSL2	BSL1	BSL0

Figure 32 Blink Start Raster register (R6)

Data bit	7	6	5	4	3	2	1	0
Set value		BEL6	BEL5	BEL4	BEL3	BEL2	BEL1	BEL0

Figure 33 Blink End Raster register (R7)

Blink Registers (R8 to R10): The blink bit registers (figure 34) designate the 8-bit groups to be blinked. Setting a bit to 1 blinks the corresponding 8-bit group. Any number of groups can be blinked; setting all the bits to 1 will blink the entire LCD panel. These bits are valid only when the BLK bit of control register 2 is 1. R10's data bits 7 to 4 are unused; they should be set to 0 when written to.

Partial Display Block Register (R11): The Partial display block register (figure 35) designates the block of partial display. Data bits 7 and 4 are unused; they should be set to 0 when written to.

Gray Scale Palette Registers (R12 to R15): The gray scale palette registers (figure 36) designate the grayscale level or colour. Use these registers to enable an optimal grayscale or colour display. If GRAY bit is 1, these registers are inactive. Data bits 7 to 5 are unused; they should be set to 0 when written to.

HD66420

	Data bit	7	6	5	4	3	2	1	0
R8	Set value	BK0	BK1	BK2	BK3	BK4	BK5	BK6	BK7
R9	Set value	BK8	BK9	BK10	BK11	BK12	BK13	BK14	BK15
R10	Set value					BK16	BK17	BK18	BK19

Figure 34 Blink Registers (R8, R9, R10)

Data bit	7	6	5	4	3	2	1	0
Set value					PB3	PB2	PB1	PB0

Set value	Row no.	Set value	Row no.
H'00	COM1 to COM8	H'05	COM80 to COM73
H'01	COM9 to COM16	H'06	COM72 to COM65
H'02	COM17 to COM24	H'07	COM64 to COM57
H'03	COM25 to COM32	H'08	COM56 to COM49
H'04	COM33 to COM40	H'09	COM48 to COM41

(ADC= "0". If "1", reverse direction)

Figure 35 Partial Display Start Raster Register (R11)

	Data bit	7	6	5	4	3	2	1	0
R12	Set value				GP14	GP13	GP12	GP11	GP10
R13	Set value				GP24	GP23	GP22	GP21	GP20
R14	Set value				GP34	GP33	GP32	GP31	GP30
R15	Set value				GP44	GP43	GP42	GP41	GP40

Figure 36 Grayscale Palette Registers (R12 to R15)

Contrast Control and LCD Alternative Drive Cycle Register (R16): The contrast control register (figure 37) designates the contrast level of LCD display. These bits change the voltage which is supplied to LCD drivers.

The LCD alternative drive cycle register designates the number of lines that LCD drive outputs are alternated.

Data bits 7 is unused; they should be set to 0 when written to.

Table 8 Grayscale Levels

GP14	GP13	GP12	GP11	GP10	Gray scale Level	GP14	GP13	GP12	GP11	GP10	Gray scale Level
GP24	GP23	GP22	GP21	GP20		GP24	GP23	GP22	GP21	GP20	
GP34	GP33	GP32	GP31	GP30		GP34	GP33	GP32	GP31	GP30	
GP44	GP43	GP42	GP41	GP40		GP44	GP43	GP42	GP41	GP40	
0	0	0	0	0	0	1	0	0	0	0	16/31
				1	1/31					1	17/31
			1	0	2/31				1	0	18/31
				1	3/31					1	19/31
		1	0	0	4/31			1	0	0	20/31
				1	5/31					1	21/31
			1	0	6/31				1	0	22/31
				1	7/31					1	23/31
	1	0	0	0	8/31		1	0	0	0	24/31
				1	9/31					1	25/31
			1	0	10/31				1	0	26/31
				1	11/31					1	27/31
		1	0	0	12/31			1	0	0	28/31
				1	13/31					1	29/31
			1	0	14/31				1	0	30/31
				1	15/31					1	1

Table 9 LCD alternative drive cycle

CM1	CM0	Alternative Cycle
0	0	Frame
0	0	7 lines
0	0	11 lines
0	0	13 lines

Data bit	7	6	5	4	3	2	1	0
Set value		CM1	CM0	CC4	CC3	CC2	CC1	CC0

Figure 37 Contrast Control register (R16)

HD66420

Absolute Maximum Ratings

Item		Symbol	Ratings	Unit	Notes
Power Supply voltage	Logic circuit	V_{CC}	-0.3 to +7.0	V	1
	LCD drive circuit	VLCD	-0.3 to +15.0	V	
Input voltage 1		VT1	-0.3 to $V_{CC} + 0.3$	V	1, 2
Input voltage 2		VT2	0.3 to VLCD + 0.3	V	1, 3
Operation temperature		T_{opr}	-40 to +85	°C	
Storage temperature		T_{stg}	-55 to +110	°C	

Notes: 1. Measured relative to GND

2. Applies to pins M/\overline{S} , OSC, OSC1, OSC2, DB7 to DB0, \overline{RD} , \overline{WR} , \overline{CS} , RS, \overline{RES} , CL1, M, FLM

3. Applies to pins V10, V20, V30, V40 and V50

4. If the LSI is used beyond its absolute maximum rating, it may be permanently damaged.

It should always be used within the limits of its electrical characteristics to prevent malfunction or unreliability.

Electrical Characteristics

DC Characteristics ($V_{CC} = 2.2$ to $5.5V$, $GND = 0V$, $VLCD = 6$ to $13V$, $T_a = -40$ to $+85^{\circ}C$)*10

Item	Symbol	Terminals	Min	Typ	Max	Unit	Test Condition	Notes
I/O leakage current	I _{IOL}		-1	—	1	μA	V _{in} = V _{CC} to GND	1
V-pins leakage current	I _{VL}		-10	—	10	μA	V _{in} = GND to VLCD	2
Driver on resistance	R _{on}	SEG1 to SEG160 COM1 to COM80			20	kΩ	I _{ON} = 100 μA VLCD = 6 V	3
Input high voltage	V _{IH1}		0.8 × V _{CC}	—	V _{CC}	V		1
Input low voltage	V _{IL1}		0	—	0.2 × V _{CC}	V		1
Output high voltage	V _{OH}	DB7 to DB0	0.8 × V _{CC}	—	V _{CC}	V	I _{OH} = -50 μA	4
Output low voltage	V _{OL}	DB7 to DB0	0	—	0.2 × V _{CC}	V	I _{OL} = 50 μA	4
Current consumption during display	I _{disp}	V _{CC}	—	55	80	μA	V _{CC} = 3.0 V R _f = 24 kΩ	5, 6
			—	25	40	μA		5, 7
Current consumption during standby	I _{stb}	V _{CC}	—	1	5	μA		5, 8
Current consumption LCD drive part	I _{lcd}	VLCD	—	30	50	μA		5, 9

- Note:
- Applies to pins: M/S, \overline{CS} , RS, \overline{WR} , \overline{RD} , \overline{RES} , OSC, DB7 to DB0, CL1, M and FLM
 - Applies to pins: V0O, V1O, V2O, V3O, V4O and V5O
 - Indicates the resistance between one pin from SEG1 to SEG160 and another pin from V1O to V5O
V1O and V2O should be near VLCD level, and V3O to V5O should be near GND level. All voltage must be within ΔV . ΔV is the range within which R_{on} is stable. V1 to V4 levels should keep following condition: VLCD ≥ V1O ≥ V2O ≥ V3O ≥ V4O ≥ V5O ≥ GND
 - Applies to pins: DB7-DB0, CO, CL1, M and FLM
 - Input and output current are excluded. When a CMOS input is floating, excess current flows from power supply to the input circuit. To avoid this, V_{IH} and V_{IL} must be held to V_{CC} and GND levels, respectively.
The current which flows at resistive divider and LCD are excluded.
Where the unmolded side of LSI is exposed to light, excess current flows. Use under sealed condition.
 - Specified under following conditions:
Internal oscillator is used; R_f = 240kΩ
32-levels gray scale mode; GRAY = 0
V_{CC} = 3.0V
Checker board is displayed
No access fro CPU
 - Specified under following conditions:
Internal oscillator is used; R_f = 240kΩ

HD66420

- 4-levels gray scale mode; GRAY = 1
- $V_{CC} = 3.0V$
- Checker board is displayed
- No access fro CPU
- 8. Measured during stand-by mode.
- $V_{CC} = 3.0V$
- 9. Specified under following conditions:
 - Internal power supply circuit is used.
 - Resister value is $5M\Omega$ which is connected between IREFM and GND
 - $V_{CC} = 3.0V$, VLCD = 12V, IREFP = V_{CC} , GREF = GND
- 10. Specified at +75°C for die products.

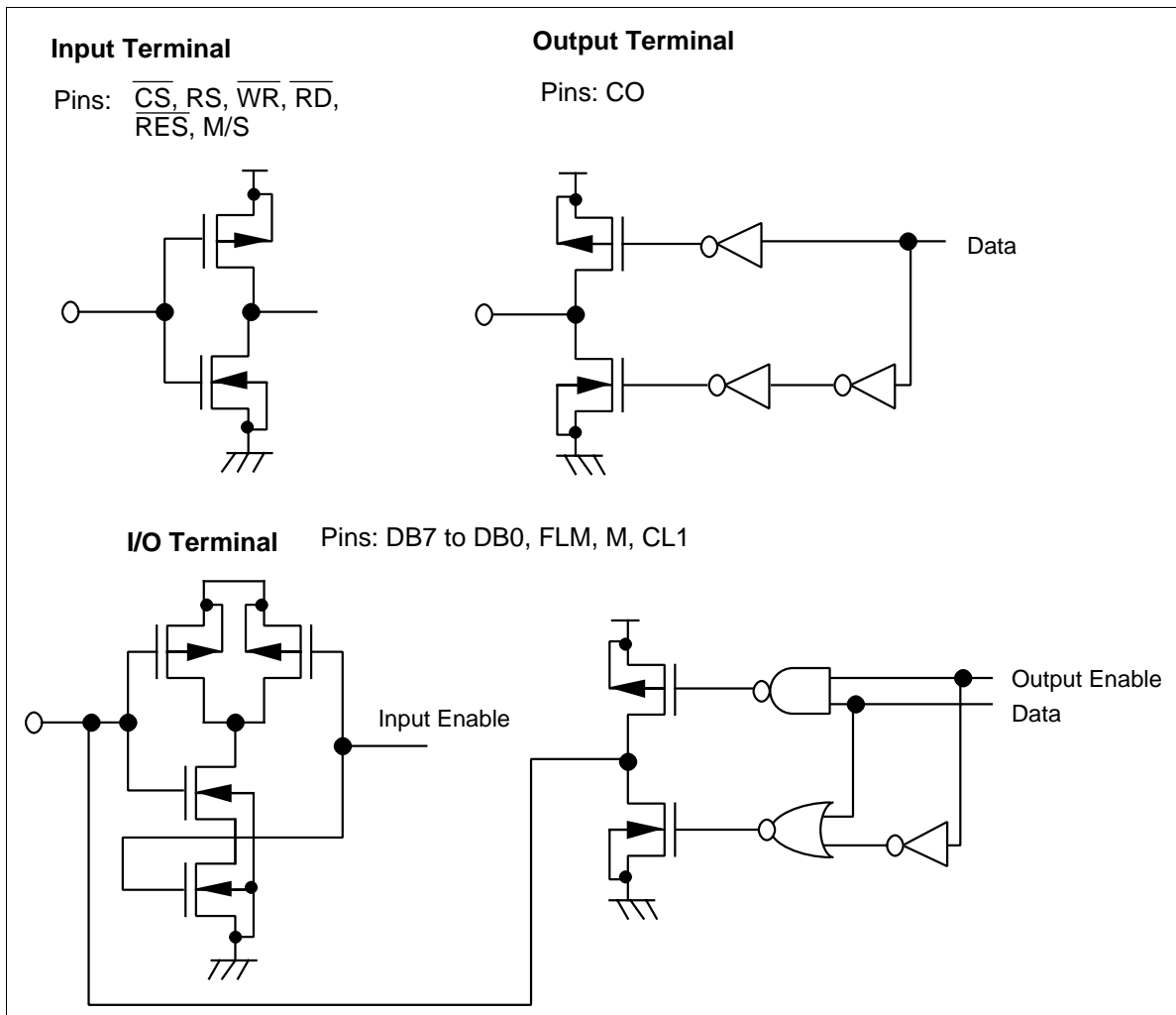

Figure 38 Terminal Configuration

AC Characteristics ($V_{CC} = 2.2V$ to $5.5V$, $GND = 0V$, $T_a = -40$ to $+85^\circ C$)*

Clock Characteristics

Item	Symbol	Min	Typ	Max	Unit	Notes
Oscillation frequency	f_{OSC}	130	180	230	kHz	$R_f = 240\text{ k}\Omega$, $V_{CC} = 3.0\text{ V}$
External clock frequency	f_{CP}	50	—	400	kHz	
External clock duty cycle	Duty	45	50	55	%	
External clock fall time	t_r	—	—	0.2	μs	
External clock rise time	t_f	—	—	0.2	μs	

Reset Timing

Item	Symbol	Min	Typ	Max	Unit	Notes
RES low-level width	t_{RES}	1	—	—	ms	

Note: Specified at $+75^\circ C$ for die products.

MPU Interface

Item	Symbol	Min	Typ	Max	Unit	Notes
RD low-level width	t_{WRDL}	250	—	—	ns	$V_{CC} = 2.2\text{ V to }3.0\text{ V}$
		190	—	—	kHz	$V_{CC} = 3.0\text{ V to }5.5\text{ V}$
RD high-level width	t_{WRDH}	450	—	—	ns	
WR low-level width	t_{WWRL}	250	—	—	ns	$V_{CC} = 2.2\text{ V to }3.0\text{ V}$
		190	—	—	ns	$V_{CC} = 3.0\text{ V to }5.5\text{ V}$
WR high-level width	t_{WWRH}	450	—	—	ns	
Address setup time	t_{AS}	10	—	—	ns	
Address hold time	t_{AH}	10	—	—	ns	
Data delay time	t_{DDR}	—	—	180	ns	$V_{CC} = 2.2\text{ V to }3.0\text{ V}$
		—	—	150	ns	$V_{CC} = 3.0\text{ V to }5.5\text{ V}$
Data output hold time	t_{DHR}	10	—	—	ns	
Data setup time	t_{DSW}	150	—	—	ns	$V_{CC} = 2.2\text{ V to }3.0\text{ V}$
		100	—	—	μs	$V_{CC} = 3.0\text{ V to }5.5\text{ V}$
Data hold time	t_{DHW}	10	—	—	ns	

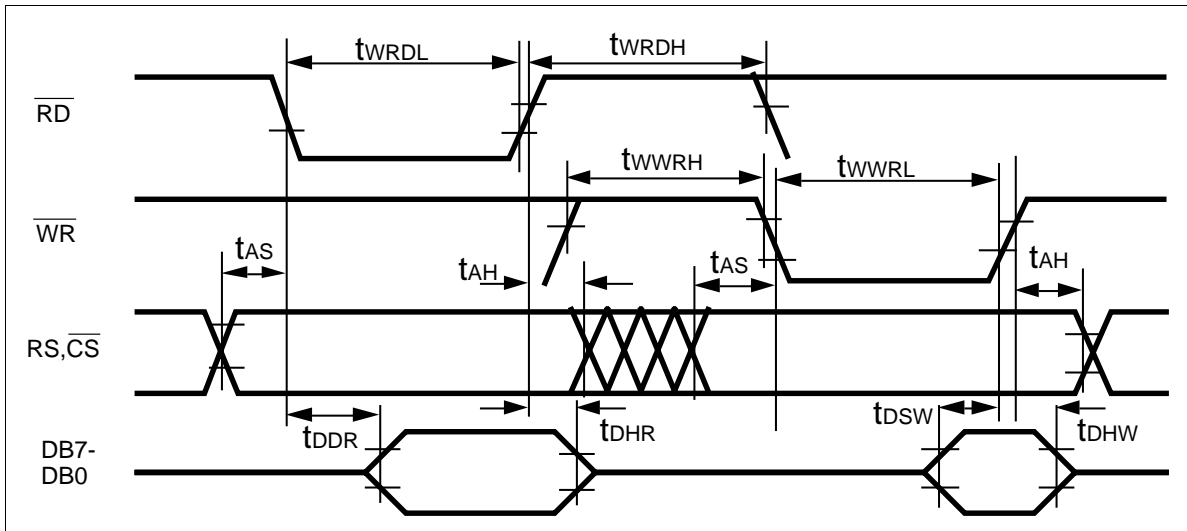

Figure 39 MPU Interface