

MAS9251**Regulated Charge Pump
DC/DC Converter**

This is preliminary information on a new product under development. Micro Analog Systems Oy reserves the right to make any changes without notice.

Preliminary

- **Solution without Inductors**
- **100 mA Output Current**
- **Fixed (5 V) or Adjustable Output Voltage**
- **Low Noise**
- **1 MHz Switching Frequency**
- **$I_{CC} < 1 \mu A$ in Shut Down**
- **MSOP-8 and CSP Packages**

DESCRIPTION

MAS9251 is a low noise, constant frequency switched capacitor voltage doubler with regulated output. In the adjustable output version an external feedback pin allows the output voltage to be adjusted.

The high switching frequency of MAS9251 guarantees low output ripple even with small ceramic capacitors. The shutdown control pin can be used to turn off the device for power saving. MAS9251 is equipped with soft-start feature, which

reduces the circuit's disturbance to power supply lines during start-up by limiting the maximum input current.

Low operating input voltage and low external part count make MAS9251 ideal for small battery powered portable systems. An internal thermal protection circuit prevents the device from overheating. Also the maximum output current is internally limited.

FEATURES

- Two versions:
 - Adjustable Output
 - Fixed 5 V Output
- Solution without Inductors
- Soft-Start
- Output Accuracy $< \pm 4\%$
- Low External Part Count
- Low Noise
- Input Voltage Range: 2.7 V... 4.5 V
- Shutdown Control
- 1 MHz Switching Frequency
- Internal Thermal Shutdown
- Short Circuit Protection
- MSOP-8 and CSP Packages

APPLICATIONS

- LED Backlighting
- White LED Driver
- LED Brightness Control
- Li-Ion Battery Backup Supplies
- Local 3 V to 5 V Conversion
- Smart Card Readers
- PCMCIA Local 5 V Supplies

PIN CONFIGURATION

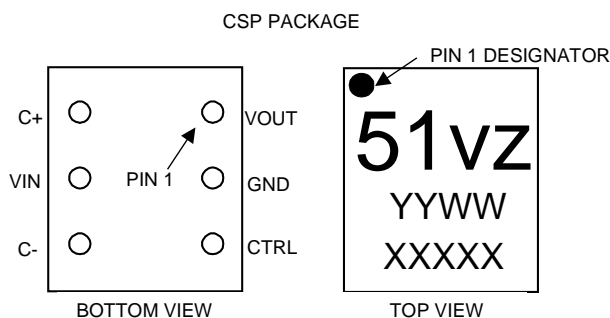
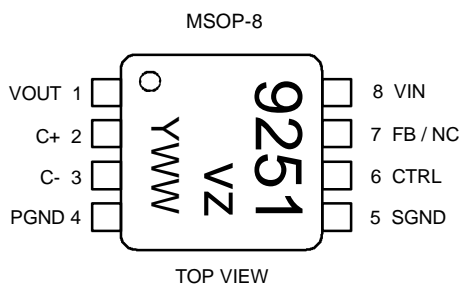

Top Marking Information:
 vz = Product Specific Code, see p.11 Ordering Information
 (Y)YWW = Year Week
 XXXXX = Lot Number

PIN DESCRIPTION

Pin Name	Pin Number in MSOP-8	Pin Number in CSP	Type	Function
VOUT	1	1	O	Regulated Output Voltage
C+	2	6	I/O	Flying Capacitor Positive Terminal
C-	3	4	I/O	Flying Capacitor Negative Terminal
PGND	4	2	G	Ground for Switching Currents
SGND	5	-	G	Ground for Analog Blocks
CTRL	6	3	I	Enable/Disable Pin for Charge Pump (Logic 0 = Disable, Logic 1 = Enable)
FB	7	-	I/O	Feedback Input Pin
VIN	8	5	P	Input Supply Voltage

G = Ground, I = Input, O = Output, P = Power

BLOCK DIAGRAM

◆ **MAS9251AF: Fixed 5 V Output Voltage Charge Pump**

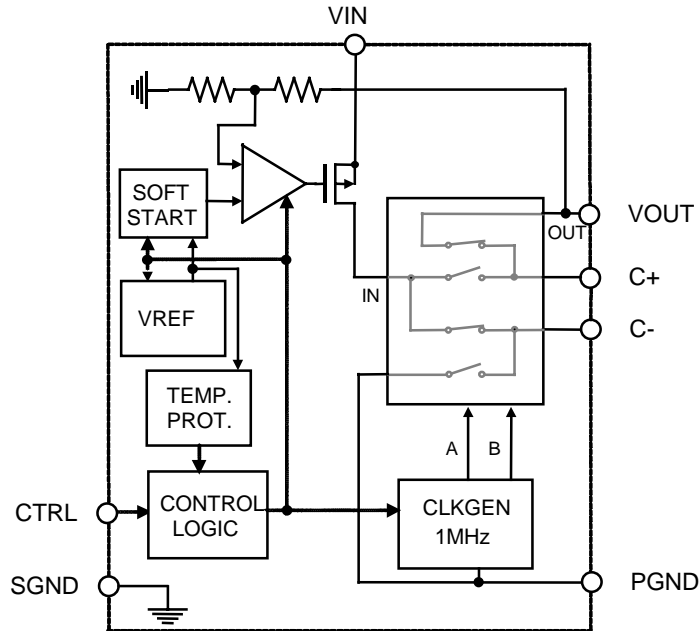

◆ **MAS9251AS: Adjustable Output Voltage Charge Pump**

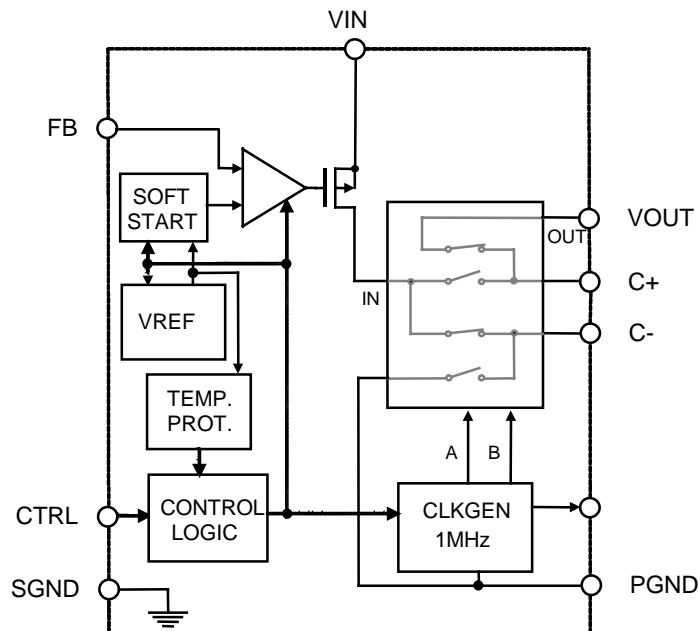

ABSOLUTE MAXIMUM RATINGS

All voltages with respect to ground.

Parameter	Symbol	Conditions	Min	Max	Unit
Supply Voltage	V_{IN}		-0.3	6	V
Output Voltage	V_{OUT}		-0.3	6	V
CTRL and FB Input Voltages	V_{CTRL}, V_{FB}	$V_{IN} \leq 5.7 \text{ V}$ $5.7 \text{ V} < V_{IN} \leq 6 \text{ V}$	-0.3 -0.3	$V_{IN} + 0.3$ 6	V
ESD Rating		Human Body Model (HBM)		2	kV
Junction Temperature	T_{Jmax}			+175 (limited)	°C
Storage Temperature	T_S		-55	+150	°C
Short Circuit Duration	t_{SC}		Indefinite		s

Stresses beyond those listed may cause permanent damage to the device. The device may not operate under these conditions, but it will not be destroyed.

RECOMMENDED OPERATING CONDITIONS

All voltages with respect to ground.

Parameter	Symbol	Conditions	Min	Typ	Max	Unit
Operating Junction Temperature	T_J		-40		+125	°C
Operating Ambient Temperature	T_A		-40	+27	+85	°C
Operating Supply Voltage	V_{IN}	For MAS9251AF For MAS9251AS see application information p 7	2.7	3.6	4.5	V
Output Voltage	V_{OUT}	For adjustable output version	0.84		5.3	

ELECTRICAL CHARACTERISTICS

 $T_A = -40^\circ\text{C}$ to $+85^\circ\text{C}$, typical values at $T_A = 27^\circ\text{C}$, $V_{IN} = 3.6 \text{ V}$, $V_{OUT} = 5.0 \text{ V}$, $C_{IN} = 1 \mu\text{F}$, $C_{FLY} = 1 \mu\text{F}$, $C_{OUT} = 1 \mu\text{F}$, $V_{CTRL} = V_{IN}$, unless otherwise specified.

◆ Voltage Parameters

Parameter	Symbol	Conditions	Min	Typ	Max	Unit
Output Voltage Tolerance	V_{OUT}	$V_{IN} = 2.7 \text{ V} \dots 4.5 \text{ V}$, $I_{OUT} \leq 40 \text{ mA}$ $V_{IN} = 3.1 \text{ V} \dots 4.5 \text{ V}$, $I_{OUT} = 100 \text{ mA}$	-4 -4		+4 +4	% V_{NOM}
Output Voltage Ripple	V_R	$V_{IN} = 3 \text{ V}$, $I_{OUT} = 100 \text{ mA}$		80		mV _{P-P}
Feedback Voltage Reference	V_{FB}	All conditions (internally controlled reference)		0.84		V

◆ Current Parameters

Parameter	Symbol	Conditions	Min	Typ	Max	Unit
Continuous Output Current	I_{OUT}	$V_{IN} = 3.1 \text{ V} \dots 4.5 \text{ V}$			100	mA
Short Circuit Current	I_{SC}	$V_{IN} = 3.6 \text{ V}$, $R_L = 0 \Omega$		300		mA
Feedback Input Current	I_{FB}	$V_{FB} = 0.84 \text{ V}$			0.1	μA
Current Consumption	I_{CC}	$I_{OUT} = 0 \text{ mA}$		4.5		mA
Shutdown Current	I_{SHDN}	$V_{CTRL} = 0 \text{ V}$, $V_{OUT} = 0 \text{ V}$ $T_A = +27^\circ\text{C}$ $T_A = +85^\circ\text{C}$		0.01	1 5	μA

◆ Thermal Protection

Parameter	Symbol	Conditions	Min	Typ	Max	Unit
Threshold High	T_H		145	160	175	°C
Threshold Low	T_L		135	150	165	°C

The hysteresis of 10 °C prevents the device from turning on too soon after thermal shut-down.

◆ Shutdown Terminal Specifications

Parameter	Symbol	Conditions	Min	Typ	Max	Unit
Shutdown Voltage OFF State ON State	V_{CTRL}		-0.3 1.6		0.55 $V_{IN} + 0.3$	V
Shutdown Control Input Pin Current	I_{CTRL}	$V_{CTRL} = V_{IN}$ $V_{CTRL} = 0 V$		4 0	10	μA

If CTRL-pin is not connected, MAS9251 is in OFF state (900 kΩ pull-down resistor to ground).

◆ Power Dissipation

Parameter	Symbol	Conditions	Min	Typ	Max	Unit
Thermal Resistance MSOP-8 (Junction-to-Air)	R_{JA}	typical PC board mounting		206.3		°C/W
Maximum Power Dissipation	P_d	any ambient temperature	$P_{dMAX} = \frac{T_{JMAX} - T_A}{R_{JA}}$ Note 1			W
Efficiency	η	$V_{IN} = 3 V, I_{OUT} = 50 mA$		80		%

Note 1: $T_{J(MAX)}$ denotes maximum operating junction temperature (+125°C), T_A ambient temperature, and R_{JA} junction-to-air thermal resistance (206.3°C/W).

◆ Dynamic Parameters

Parameter	Symbol	Conditions	Min	Typ	Max	Unit
Start-up Time (from control signal edge to 90% of V_{NOM})	$t_{start-up}$	$V_{CTRL} = 0$ to V_{IN} , $V_{IN} = 3 V$, $I_{OUT} \leq 100 mA$		1		ms
Switching Frequency	F_{OSC}		0.6	1	1.8	MHz

APPLICATION INFORMATION

◆ Fixed 5 V Voltage Supply

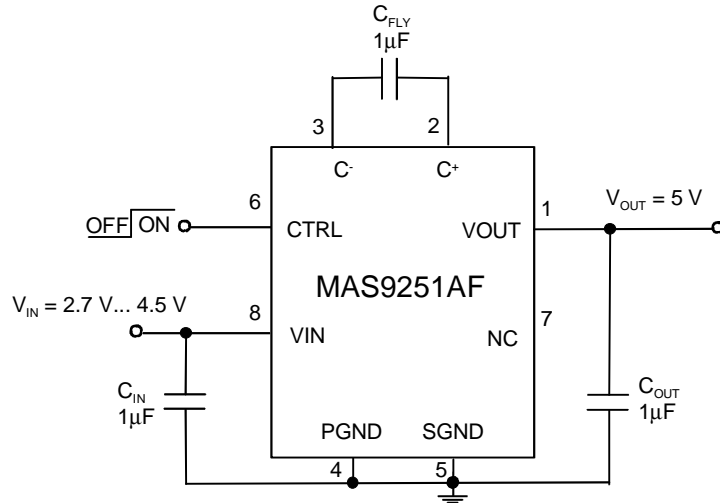

◆ Adjustable Voltage Supply

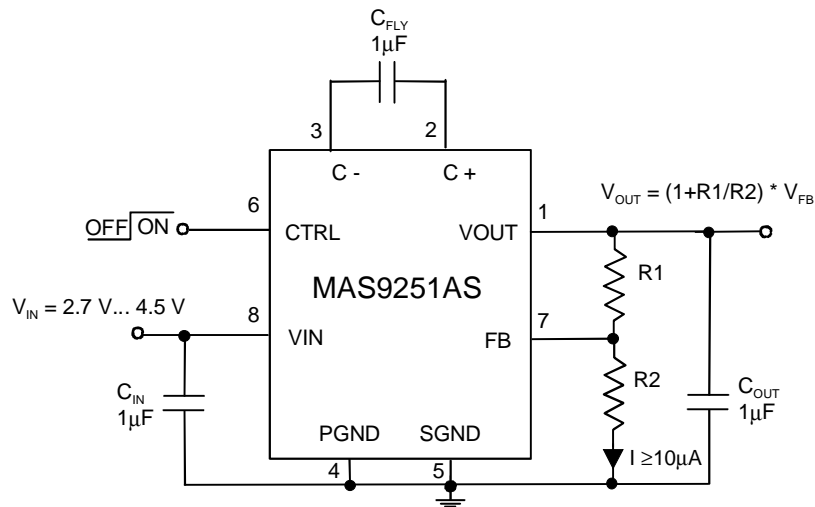

N.B.! The values of R1 and R2 should be selected so that V_{OUT} does not exceed 5.3 V.

Parameter	Symbol	Min	Typ	Max	Unit	Note
Output Capacitance	C_{OUT}	0.47	1		μF	Low ESR ($< 0.1 \Omega$) ceramic capacitor recommended, especially with high load current
Flying Capacitance	C_{FLY}	0.68	1		μF	Low ESR ($< 0.1 \Omega$) ceramic capacitor required (note 2)
Input Capacitance	C_{IN}	0.47	1		μF	Low ESR ($< 0.1 \Omega$) ceramic capacitor recommended, especially with high load current

Values given on the table are minimum requirements unless otherwise specified. When selecting capacitors, tolerance and temperature coefficient must be considered to make sure that the requirement is met in all potential operating conditions.

Note 2: Polarized capacitor should never be used, since the capacitor voltage can reverse during operation.

APPLICATION INFORMATION

◆ MAS9251AS Max Output Voltage vs. Input Voltage

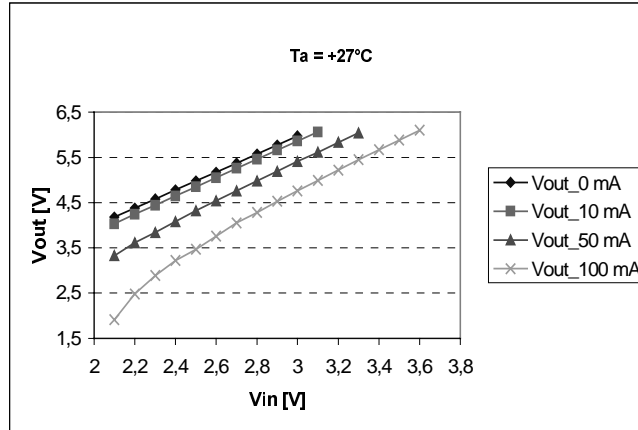

◆ LED Driver with Current Feedback and PWM Brightness Control

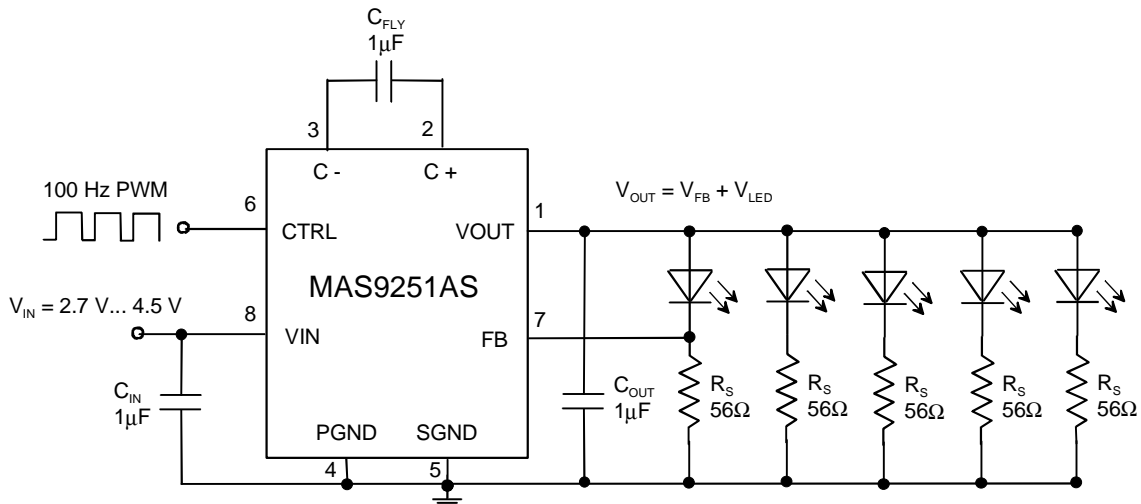

◆ White Backlighting LED Driver with Constant 5 V Output and PWM Brightness Control

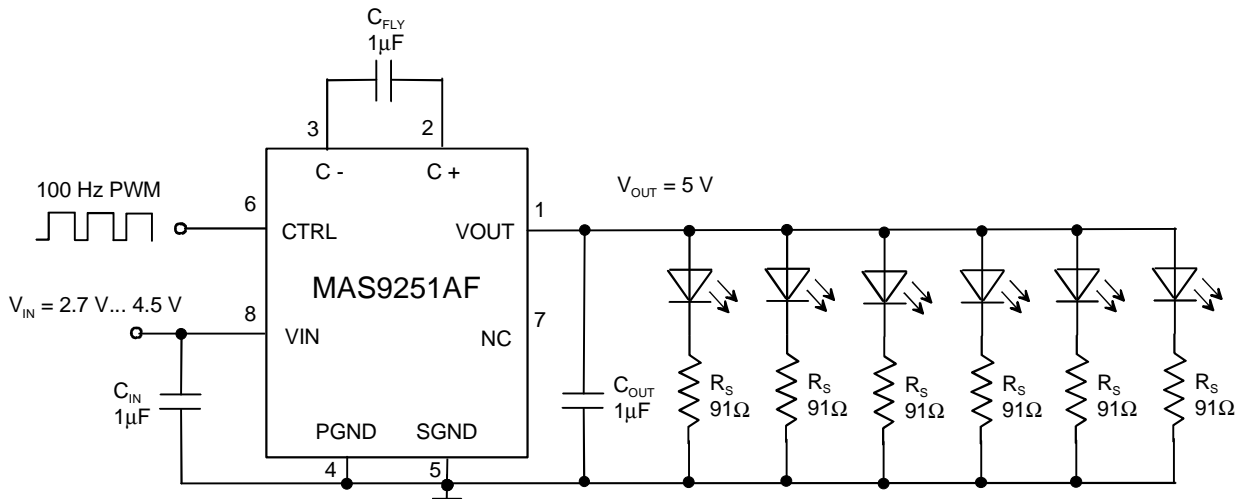

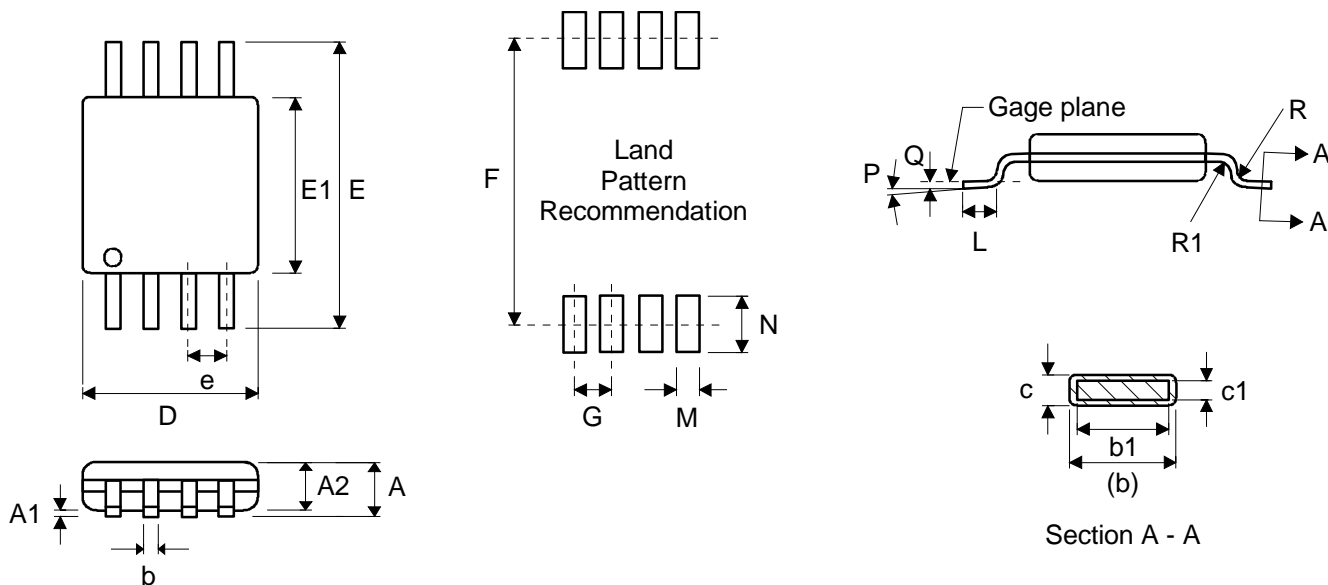
PACKAGE (MSOP-8) OUTLINE

Symbol	Min	Nom	Max	Unit
A			1.10	mm
A1	0		0.15	mm
A2	0.75	0.85	0.95	mm
b	0.22		0.38	mm
b1	0.22	0.30	0.33	mm
c	0.08		0.23	mm
c1	0.08		0.18	mm
D		3.00 BSC		mm
E		4.90 BSC		mm
E1		3.00 BSC		mm
e		0.65 BSC		mm
F		4.8		mm
G		0.65		mm
L	0.40	0.60	0.80	mm
(Terminal length for soldering)				
M		0.41		mm
N		1.02		mm
P	0°		8°	
Q		0.25 BSC		mm
R	0.07			mm
R1	0.07			mm

Dimensions do not include mold or interlead flash, protrusions or gate burrs.
 All measurement according to JEDEC standard MO-187.

SOLDERING INFORMATION

Resistance to Soldering Heat	According to RSH test IEC 68-2-58/20 2*220°C
Maximum Reflow Temperature	235°C
Maximum Number of Reflow Cycles	2
Seating Plane Co-planarity	max 0.08 mm
Lead Finish	Solder plate 7.62 - 25.4 μm, material Sn 85% Pb 15%

EMBOSSED TAPE SPECIFICATIONS

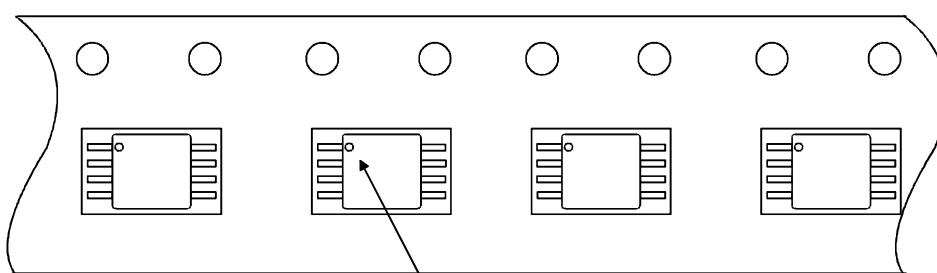
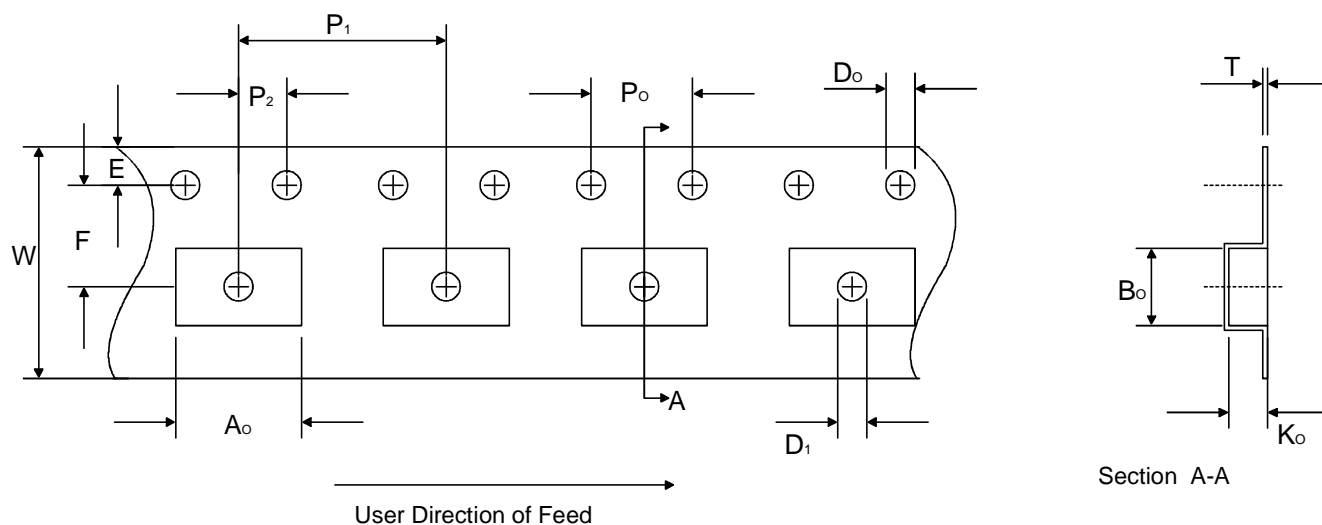

Pin 1 Designator

Dimension	Min/Max	Unit
A_o	5.00 ±0.10	mm
B_o	3.20 ±0.10	mm
D_o	1.50 +0.1/-0.0	mm
D_1	1.50 min	mm
E	1.75	mm
F	5.50 ±0.05	mm
K_o	1.45 ±0.10	mm
P_o	4.0	mm
P_1	8.0 ±0.10	mm
P_2	2.0 ±0.05	mm
T	0.3 ±0.05	mm
W	12.00 +0.30/-0.10	mm

REEL SPECIFICATIONS

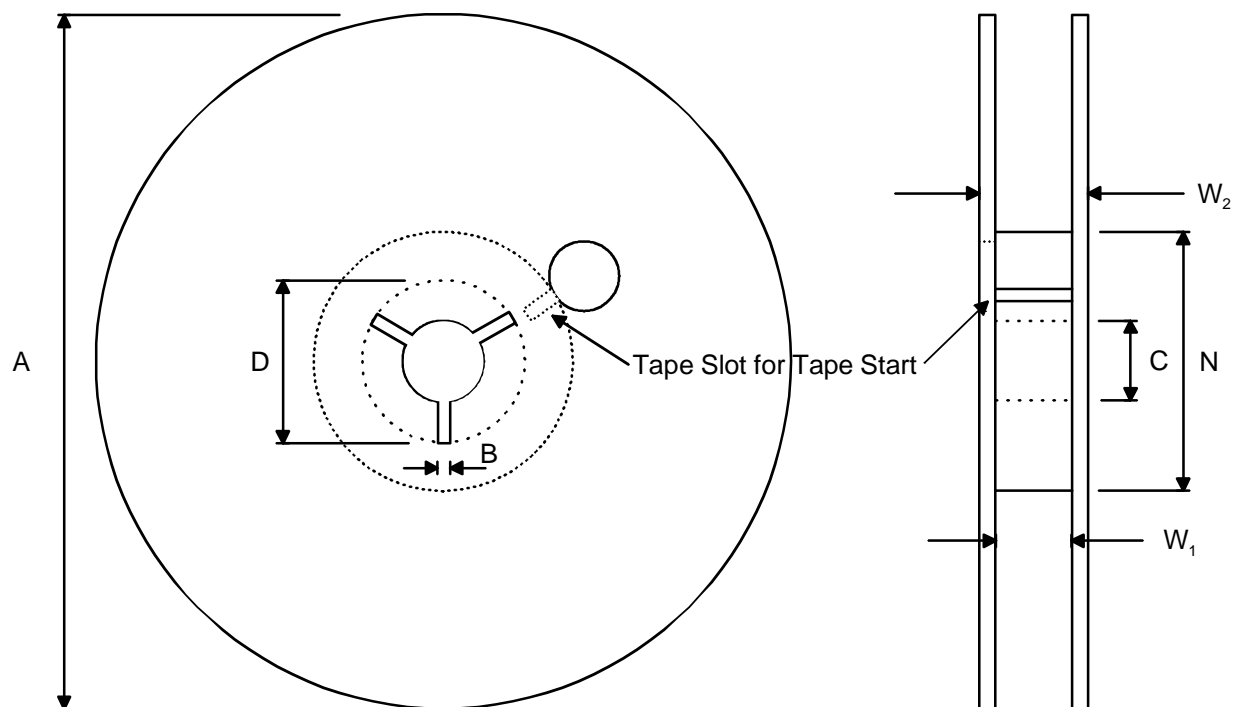

5000 Components on Each Reel

Reel Material: Conductive, Plastic Antistatic or Static Dissipative

Carrier Tape Material: Conductive

Cover Tape Material: Static Dissipative

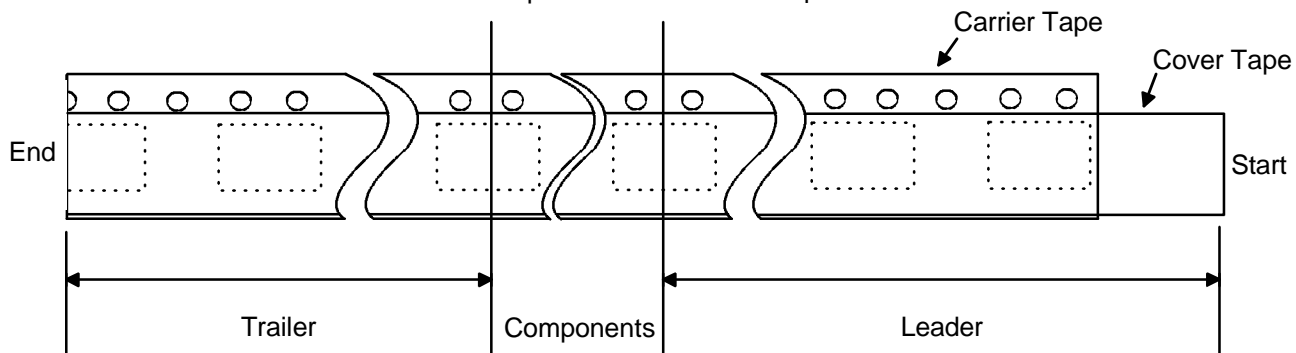

Dimension	Min	Max	Unit
A		330	mm
B	1.5		mm
C	12.80	13.50	mm
D	20.2		mm
N	50		mm
W ₁ (measured at hub)	12.4	14.4	mm
W ₂ (measured at hub)		18.4	mm
Trailer	160		mm
Leader	390, of which minimum 160 mm of empty carrier tape sealed with cover tape		mm
Weight		1500	g

ORDERING INFORMATION

Product Code	Product	Top Marking (vz)	Package	Comments
MAS9251ASMF-T	Fixed 5 V Output Voltage Charge Pump	AF (T1)	MSOP-8	Tape and Reel
MAS9251ASMS-T	Adjustable Output Voltage Charge Pump	AS (T2)	MSOP-8	Tape and Reel
MAS9251ACAF-T	Fixed 5 V Output Voltage Charge Pump	AF	Chip Scale Package (CSP) (to be qualified)	Tape and Reel

LOCAL DISTRIBUTOR

--

MICRO ANALOG SYSTEMS OY CONTACTS

Micro Analog Systems Oy Kamreerintie 2, P.O.Box 51 FIN-02771 Espoo, FINLAND Http://www.mas-oy.com	Tel. (09) 80 521 Tel. Int. +358 9 80 521 Telefax +358 9 805 3213 E-mail: info@mas-oy.com
--	--

NOTICE

Micro Analog Systems Oy reserves the right to make changes to the products contained in this data sheet in order to improve the design or performance and to supply the best possible products. Micro Analog Systems Oy assumes no responsibility for the use of any circuits shown in this data sheet, conveys no license under any patent or other rights unless otherwise specified in this data sheet, and makes no claim that the circuits are free from patent infringement. Applications for any devices shown in this data sheet are for illustration only and Micro Analog Systems Oy makes no claim or warranty that such applications will be suitable for the use specified without further testing or modification.