

## DESCRIPTION

The SC1205 is a cost effective Dual MOSFET Driver designed for switching High and Low side Power MOSFETs. Each driver is capable of driving a 3000pF load in 20ns rise/fall time and has a 20ns max propagation delay from input transition to the gate of the power FET's. An internal Overlap Protection Circuit prevents shoot-through from Vin to GND in the main switching and synchronous MOSFET's. The Overlap Protection circuit ensures the Bottom FET does not turn on until the Top FET source has reached a voltage low enough to prevent cross-conduction.

The high current drive capability (2A peak) allows fast switching, thus reducing switching losses at high (1MHz) PWM frequencies. The high voltage CMOS process allows operation from 5-25 Volts at top MOSFET drain, thus making SC1205 suitable for battery powered applications. Connecting Enable pin (EN) to logic low shuts down both drives and reduces operating current to less than 10uA.

An Under-Voltage-Lock-Out circuit is included to guarantee that both driver outputs are low when the 5V logic level is less than or equal to 4.4V (typ) at supply ramp up (4.35V at supply ramp down). An Internal temperature sensor shuts down all drives in the event of overtemperature. SC1205 is fabricated utilizing CMOS technology for low quiescent current. The SC1205 is offered in a standard SO-8 package.

## PIN CONFIGURATION

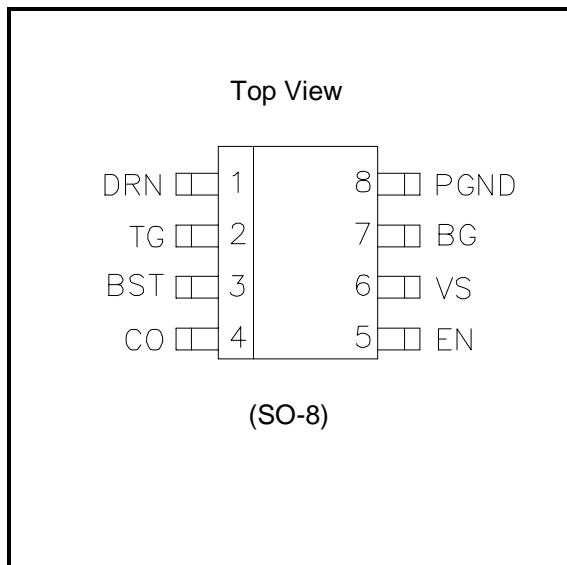

## FEATURES

- Fast rise and fall times (15ns typical with 3000pf load)
- 2Amp peak drive current
- 14ns max Propagation delay (BG going low)
- Adaptive Non-overlapping Gate Drives provide shoot-through protection
- Floating top drive switches up to 25V
- Under-Voltage lock-out
- Overtemperature protection
- Less than 10uA supply current when EN is low
- Low cost

## APPLICATIONS

- High Density synchronous power supplies
- Motor Drives/Class-D amps/Half bridge drivers
- High frequency (to 1.2 MHz) operation allows use of small inductors and low cost caps in place of electrolytics
- Portable computers
- Battery powered applications

## ORDERING INFORMATION

DEVICE <sup>(1)</sup>	PACKAGE	TEMP. RANGE (T <sub>J</sub> )
SC1205CS	SO-8	0 - 125°C

Note:

(1) Add suffix 'TR' for tape and reel.

## BLOCK DIAGRAM

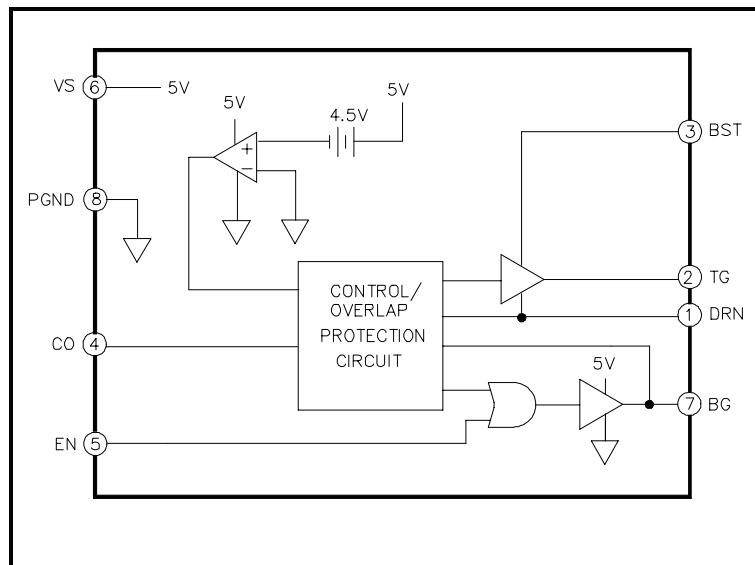

PRELIMINARY - December 7, 1999

**ABSOLUTE MAXIMUM RATINGS**

Parameter	Symbol	Conditions	Maximum	Units
V <sub>CC</sub> Supply Voltage	V <sub>MAX5V</sub>		7	V
BST to PGND	VMAX <sub>BST-PGND</sub>		30	V
BST to DRN	VMAX <sub>BST-DRN</sub>		7	V
DRN to PGND	VMAX <sub>DRN-PGN</sub>		25	V
OVP_S to PGND	VMAX <sub>OVP_S-PGND</sub>		10	V
Input pin	CO		-0.3 to 7.3	V
Continuous Power Dissipation	Pd	Tamb = 25°C, T <sub>J</sub> = 125°C Tcase = 25°C, T <sub>J</sub> = 125°C	0.66 2.56	W
Thermal Resistance Junction to Case	θ <sub>JX</sub>		40	°C/W
Thermal Resistance Junction to Ambient	θ <sub>JA</sub>		150	°C/W
Operating Temperature Range	T <sub>J</sub>		0 to +125	°C
Storage Temperature Range	T <sub>STG</sub>		-65 to +150	°C
Lead Temperature (Soldering) 10 sec	T <sub>LEAD</sub>		300	°C

NOTE:

(1) Specification refers to application circuit in Figure 1.

**ELECTRICAL CHARACTERISTICS (DC OPERATING SPECIFICATIONS)**

 Unless specified:  $-0 < \theta_J < 125^\circ\text{C}$ ; V<sub>CC</sub> = 5V;  $4\text{V} \leq V_{\text{BST}} \leq 26\text{V}$ 

PARAMETER	SYMBOL	CONDITIONS	MIN	TYP	MAX	UNITS
<b>POWER SUPPLY</b>						
Supply Voltage	V <sub>CC</sub>	V <sub>CC</sub>	4.15	5	6.0	V
Quiescent Current, operating	Iq <sub>op</sub>	V <sub>CC</sub> = 5V, CO = 0V		1		ma
Quiescent Current	Iq <sub>stby</sub>	EN = 0V			10	μA
<b>UNDER-VOLTAGE LOCKOUT</b>						
Start Threshold	V <sub>START</sub>		4.2	4.4	4.6	V
Hysteresis	V <sub>hysUVLO</sub>			0.05		V
Logic Active Threshold	V <sub>ACT</sub>				1.5	V

PRELIMINARY - December 7, 1999

**ELECTRICAL CHARACTERISTICS (DC OPERATING SPECIFICATIONS) Cont.**

PARAMETER	SYMBOL	CONDITIONS	MIN	TYP	MAX	UNITS
<b>CO</b>						
High Level Input Voltage	$V_{IH}$		2.0			V
Low Level Input Voltage	$V_{IL}$				0.8	V
<b>THERMAL SHUTDOWN</b>						
Over Temperature Trip Point	$T_{OTP}$			165		°C
Hysteresis	$T_{HYST}$			10		°C
<b>HIGH-SIDE DRIVER</b>						
Peak Output Current	$I_{PKH}$			2		A
Output Resistance	$R_{src_{TG}}$	duty cycle < 2%, tpw < 100µs, $T_J = 125^{\circ}C$ , $V_{BST} - V_{DRN} = 4.5V$ , $V_{TG} = 4.0V (src) + V_{DRN}$ or $V_{TG} = 0.5V (sink) + V_{DRN}$		1		Ω
	$R_{sink_{TG}}$			.7		Ω
<b>LOW-SIDE DRIVER</b>						
Peak Output Current	$I_{PKL}$			2		A
Output Resistance	$R_{src_{BG}}$	duty cycle < 2%, tpw < 100µs, $T_J = 125^{\circ}C$ $V_{V_5} = 4.6V$ , $V_{BG} = 4V (src)$ , or $V_{LOWDR} = 0.5V (sink)$		1.2		Ω
	$R_{sink_{BG}}$			1.0		Ω

PRELIMINARY - December 7, 1999

**AC OPERATING SPECIFICATIONS**

PARAMETER	SYMBOL	CONDITIONS	MIN	TYP	MAX	UNITS
<b>HIGH-SIDE DRIVER</b>						
rise time	$t_{r_{TG}}$	$Cl = 3nF, V_{BST} - V_{DRN} = 4.6V,$ $T_J = 125^{\circ}C$		14	23	ns
fall time	$t_{f_{TG}}$	$Cl = 3nF, V_{BST} - V_{DRN} = 4.6V,$ $T_J = 125^{\circ}C$		12	19	ns
propagation delay time, TG going high	$tpdh_{TG}$	$Cl = 3nF, V_{BST} - V_{DRN} = 4.6V,$ $T_J = 125^{\circ}C$		20	32	ns
propagation delay time, TG going low	$tpdl_{TG}$	$Cl = 3nF, V_{BST} - V_{DRN} = 4.6V,$ $T_J = 125^{\circ}C$		15	24	ns
<b>LOW-SIDE DRIVER</b>						
rise time	$t_{r_{BG}}$	$Cl = 3nF, V_{V_5} = 4.6V,$ $T_J = 125^{\circ}C$		15	24	ns
fall time	$t_{f_{BG}}$	$Cl = 3nF, V_{V_5} = 4.6V,$ $T_J = 125^{\circ}C$		13	21	ns
propagation delay time BG going high	$tpdh_{BGHI}$	$Cl = 3nF, V_{V_5} = 4.6V,$ $T_J = 125^{\circ}C, DRN \leq 1V$		12	19	ns
propagation delay time BG going low	$tpdl_{BG}$	$Cl = 3nF, V_{V_5} = 4.6V,$ $T_J = 125^{\circ}C$		7	12	ns
<b>UNDER-VOLTAGE LOCKOUT</b>						
V <sub>5</sub> ramping up	$tpdh_{UVLO}$	EN is High			10	us
V <sub>5</sub> ramping down	$tpdl_{UVLO}$	EN is High			10	us

PRELIMINARY - December 7, 1999

**PIN DESCRIPTION**

Pin #	Pin Name	Pin Function
1	DRN	This pin connects to the junction of the switching and synchronous MOSFET's. This pin can be subjected to a -2V minimum relative to PGND without affecting operation.
2	TG	Output gate drive for the switching (high-side) MOSFET.
3	BST	Bootstrap pin. A capacitor is connected between BST and DRN pins to develop the floating bootstrap voltage for the high-side MOSFET. The capacitor value is typically between 0.1 $\mu$ F and 1 $\mu$ F (ceramic).
4	CO	TTL-level input signal to the MOSFET drivers.
5	EN	When high, this pin enables the internal circuitry of the device. When low, TG, BG and PRDY are forced low and the supply current (5V) is less than 10 $\mu$ A.
6	VS	+5V supply. A .22-1 $\mu$ F ceramic capacitor should be connected from 5V to PGND very close to this pin.
7	BG	Output drive for the synchronous MOSFET.
8	PGND	Ground.

**NOTE:**

(1) All logic level inputs and outputs are open collector TTL compatible.

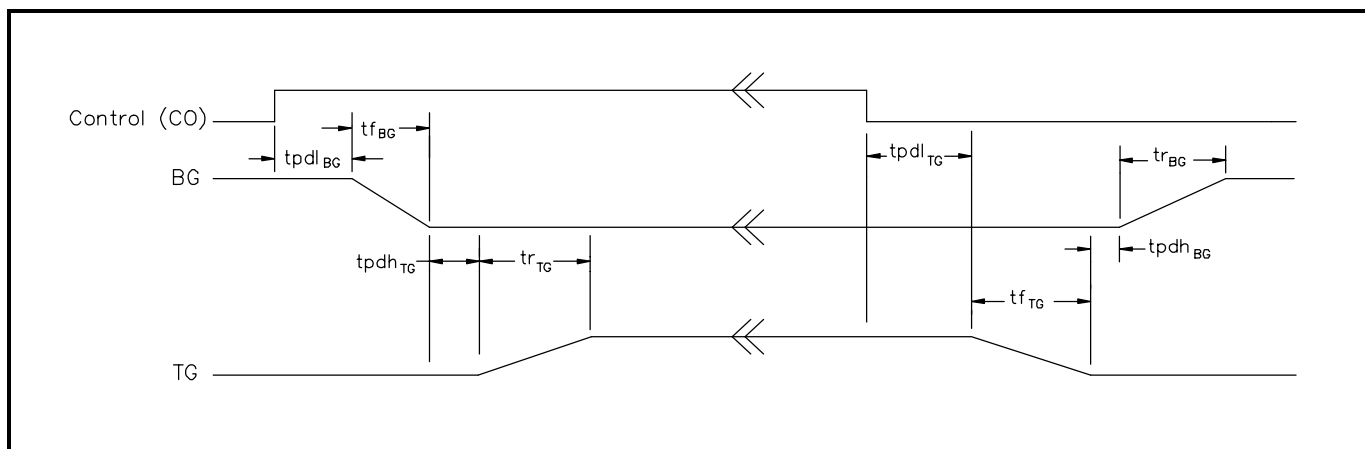
**TIMING DIAGRAM**

PRELIMINARY - December 7, 1999

Figure 1 - Timing characteristics while driving a 3nf load at Tamb = 125°C after CO low to high transition.

Tek Run: 2.50GS/s ET Average

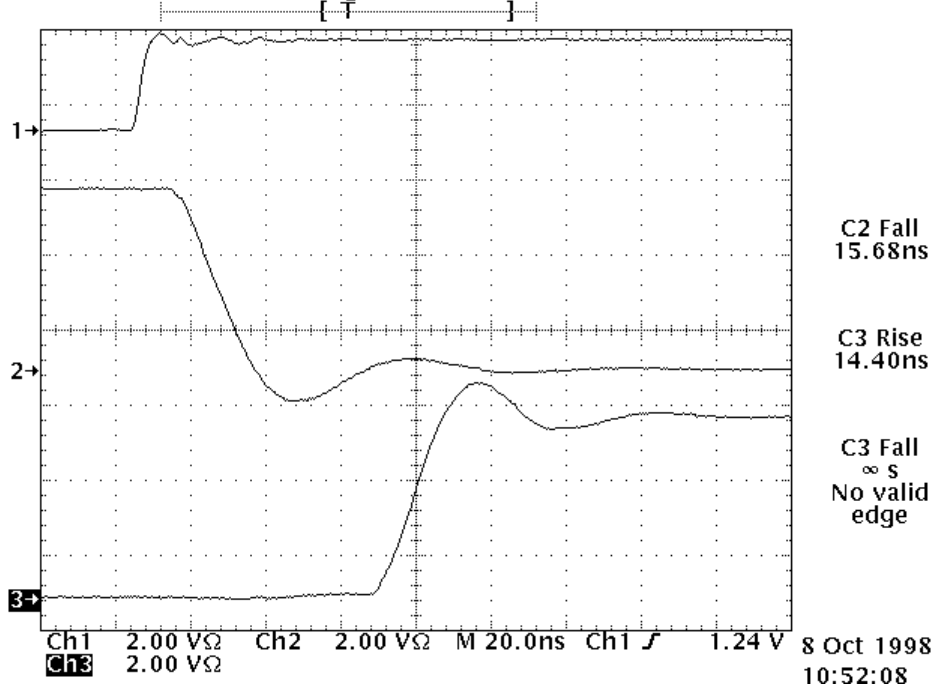

Ch1. CO input going high (start of cycle)

Ch2. BG drive

Ch3. TG drive

 Load = 3 nf  
 C\_delay = 0

Tek Run: 5.00GS/s ET Average

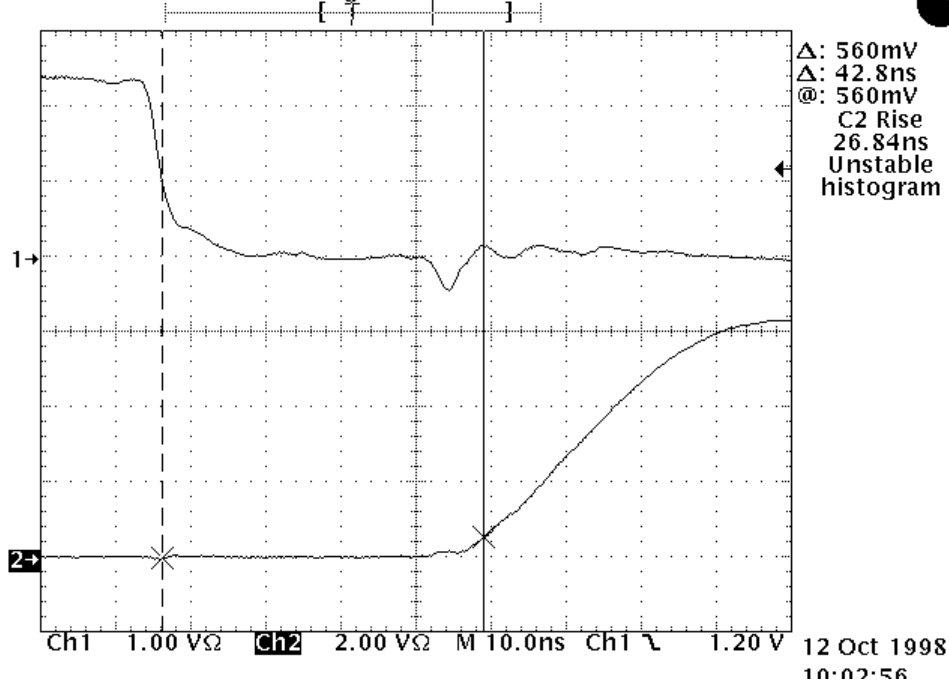

Ch1. DRN (phase node) voltage going low

Ch2. BG going high

 Load = 3 nf  
 C\_delay = 0

Figure 2-Timing characteristics while driving a 3nf load at Tamb = 125°C after DRN voltage transition to a low voltage (DRN &lt;1V)

PRELIMINARY - December 7, 1999

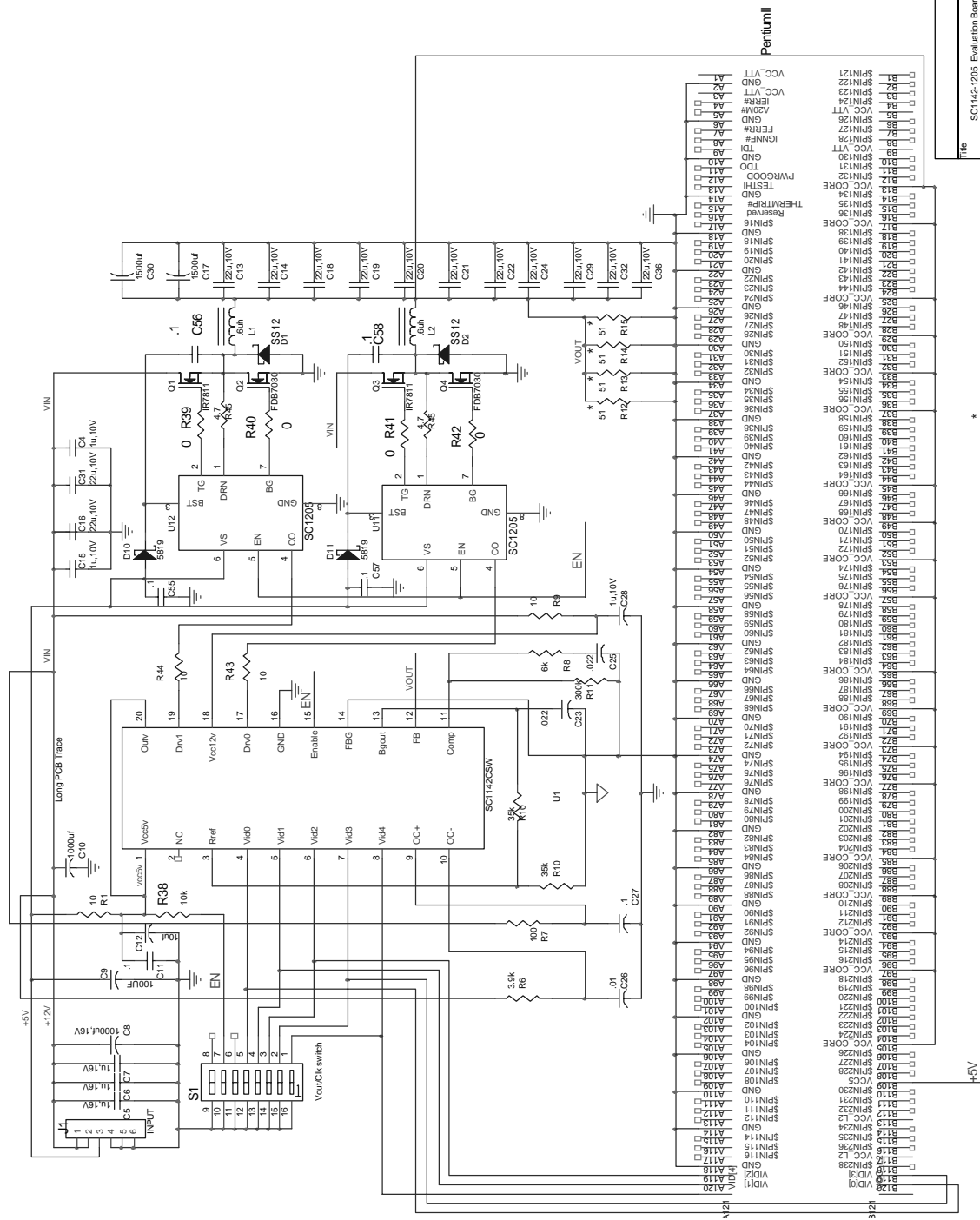
**Figure 3-SC1205 Evaluation Board**

Title		SC1205 Evaluation Board	
Doc Number	311127P.A	Rev	N/C
Size	B	Sheet	1 of 1
Date	Tuesday, June 23, 1999		

\* OPTIONAL

PRELIMINARY - December 7, 1999

**BILL OF MATERIAL**

Item	Qty	Reference	Value	Manufacturer
1	3	C4,C15,C28	1u,10V, Cer.	AVX, Murata
2	3	C5,C6,C7	1u,16V, Cer.	AVX, Murata
3	1	C8	1000uF, 16V	Nichicon, any
4	1	C9	100uF	Nichicon, any
5	1	C10	1000uf	Nichicon, any
7	1	C12	10uF	Nichicon, any
8	13	C13,C14,C16,C18,C19,C20,C21,C22,C24,C29,C31,C32,C36	22u, 10V	Murata (GRM235Y5V226Z010)
9	2	C17,C30	1500uf	Nichicon, Sanyo
10	2	C23,C25	.022	Avx, any
11	1	C26	.01	Avx, any
12	6	C11,C27,C55,C56,C57,C58	.1	Avx, any
13				
14	2	D1,D2	SS12	General Instruments, any
15	2	D10,D11	5819	General Instruments, any
16	1	J1	Input	
17	2	L1,L2	.6uh	Falco, P/N: TO2508 or SDIP0804-608M (305) 662-9076
18	2	Q1,Q3	IR7811	Int. Rectifier (310) 252-7099
19	2	Q2,Q4	FDB7030	Fairchild Semi. (408) 822-2000
20	4	R1,R9,R43,R44	10	any
21	1	R6	3.9k	any
22	1	R7	100	any
23	1	R8	6k	any
24	1	R10	35k	any
25	1	R11	300k	any
26	4	R12,R13,R14,R15	51	any, Required in asynch. operation
27	1	R38	10K	any
28	4	R39,R40,R41,R42	0	any
29	1	R45	4.7	any
30	1	S1	Vout/Clk switch	Digikey
31	1	U2	Pentium II™	Slot 1 Connector
32	1	U1	SC1142CSW	Semtech, (805) 499-2111
33	2	U11,U12	SC1205S	Semtech, (805) 499-2111



PRELIMINARY - December 7, 1999

**APPLICATION INFORMATION:**

**SC1205** is a high speed, smart dual MOSFET driver. It is designed to drive Low Rds\_On power MOSFET's with ultra-low rise/fall times and propagation delays. As the switching frequencies of PWM controllers is increased to reduce power supply and Class-D amplifier volume and cost, fast rise and fall times are necessary to minimize switching losses (TOP MOSFET) and reduce Dead-time (BOTTOM MOSFET). While Low Rds\_On MOSFET's present a power saving in I<sup>2</sup>R losses, the MOSFET's die area is larger and thus the effective input capacitance of the MOSFET is increased. Often a 50% decrease in Rds\_On more than doubles the effective input gate charge, which must be supplied by the driver. The Rds\_On power savings can be offset by the switching and dead-time losses with a sub-optimum driver. While discrete solution can achieve reasonable drive capability, implementing shoot-through, programmable delay and other house-keeping functions necessary for safe operation can become cumbersome and costly. The SC120X family of parts presents a total solution for the high-speed, high power density applications. Wide input supply range of 4.5V-25V allows use in battery powered applications, new high voltage, distributed power servers as well as Class-D amplifiers.

**THEORY OF OPERATION**

The control input (CO) to the SC1205 is typically supplied by a PWM controller that regulates the power supply output. (See Application Evaluation Schematic, Figure 3). The timing diagram demonstrates the sequence of events by which the top and bottom drive signals are applied. The shoot-through protection is implemented by holding the bottom FET off until the voltage at the phase node (intersection of top FET source, the output inductor and the bottom FET drain) has dropped below 1V. This assures that the top FET has turned off and that a direct current path does not exist between the input supply and ground, a condition which both the top and bottom FET's are on momentarily. The top FET is also prevented from turning on until the bottom FET is off. This time is internally set to 20ns.

**LAYOUT GUIDELINES**

As with any high speed, high current circuit, proper layout is critical in achieving optimum performance of the SC1205. The Evaluation board schematic (Refer

to figure 3) shows a two-phase synchronous design with all surface mountable components. While components connecting to EN are relatively non-critical, tight placement and short, wide traces must be used in layout of The Drives, DRN, and especially PGND pin. The top gate driver supply voltage is provided by bootstrapping the +5V supply and adding it the phase node voltage (DRN). Since the bootstrap capacitor supplies the charge to the top gate, it must be less than .5" away from the SC1205. Ceramic X7R capacitors are a good choice for supply bypassing near the chip. The Vcc pin capacitor must also be less than .5" away from the SC1205. The ground node of this capacitor, the SC1205 PGND pin and the Source of the bottom FET must be very close to each other, preferably with common PCB copper land with multiple vias to the ground plane (if used). The parallel Shottkey must be physically next to the Bottom FETS Drain and source. Any trace or lead inductance in these connections will drive current way from the Shottkey and allow it to flow through the FET's Body diode, thus reducing efficiency.

**PREVENTING INADVERTENT BOTTOM FET  
TURN-ON**

At high input voltages, (12V and greater) a fast turn-on of the top FET creates a positive going spike on the Bottom FET's gate through the Miller capacitance, crss of the bottom FET. The voltage appearing on the gate due to this spike is:

$$V_{spike} = V_{in} * cr_{ss} / (C_{r_{ss}} + c_{iss})$$

Where Ciss is the input gate capacitance of the bottom FET. This is assuming that the impedance of the drive path is too high compared to the instantaneous impedance of the capacitors. (since dV/dT and thus the effective frequency is very high). If the BG pin of the SC1205 is very close to the bottom FET, Vspike will be reduced depending on trace inductance, rate of rise of current, etc.

PRELIMINARY - December 7, 1999

While not shown in Figure 3, a capacitor may be added from the gate of the Bottom FET to its source, preferably less than .1" away. This capacitor will be added to Ciss in the above equation to reduce the effective spike voltage, Vspike.

The selection of the bottom MOSFET must be done with attention paid to the Crss/Ciss ratio. A low ratio reduces the Miller feedback and thus reduces Vspike. Also MOSFETs with higher Turn-on threshold voltages will conduct at a higher voltage and will not turn on during the spike. The MOSFET shown in the schematic (figure 3) has a 2 volt threshold and will require approximately 4.5 volts Vgs to be conducting, thus reducing the possibility of shoot-through. A zero ohm bottom FET gate resistor will obviously help keeping the gate voltage low.

Ultimately, slowing down the top FET by adding gate resistance will reduce di/dt which will in turn make the effective impedance of the capacitors higher, thus allowing the BG driver to hold the bottom gate voltage low. It does this at the expense of increased switching times ( and switching losses) for the top FET.

### **RINGING ON THE PHASE NODE**

The top MOSFET source must be close to the bottom MOSFET drain to prevent ringing and the possibility of the phase node going negative. This frequency is determined by:

$$F_{ring} = 1 / (2\pi * \text{Sqrt}(L_{st} * C_{oss}))$$

Where:

$L_{st}$  = The effective stray inductance of the top FET added to trace inductance of the connection between top FET's source and the bottom FET's drain added to the trace resistance of the bottom FET's ground connection.

$C_{oss}$  = Drain to source capacitance of bottom FET. If there is a Shottkey used, the capacitance of the Shottkey is added to the value.

Although this ringing does not pose any power losses due to a fairly high Q, it could cause the phase node to go too far negative, thus causing improper operation, double pulsing or at worst driver damage. On the SC1205, the drain node, DRN, can go as far as 2V below ground without affecting operation or sustaining damage.

The ringing is also an EMI nuisance due to its high resonant frequency. Adding a capacitor, typically 1000-2000pf, in parallel with Coss of the bottom FET

can often eliminate the EMI issue. If double pulsing is caused due to excessive ringing, placing 4.7-10 ohm resistor between the phase node and the DRN pin of the SC1205 should eliminate the double pulsing. Proper layout will guarantee minimum ringing and eliminate the need for external components. Use of SO-8 or other surface mount MOSFETs while increasing thermal resistance, will reduce lead inductance as well as radiated EMI.

### **OVER TEMP SHUTDOWN**

The SC1205 will shutdown by pulling both driver if its junction temperature, Tj, exceeds 165 °C.

PRELIMINARY - December 7, 1999

Tek Run: 500MS/s ET Sample

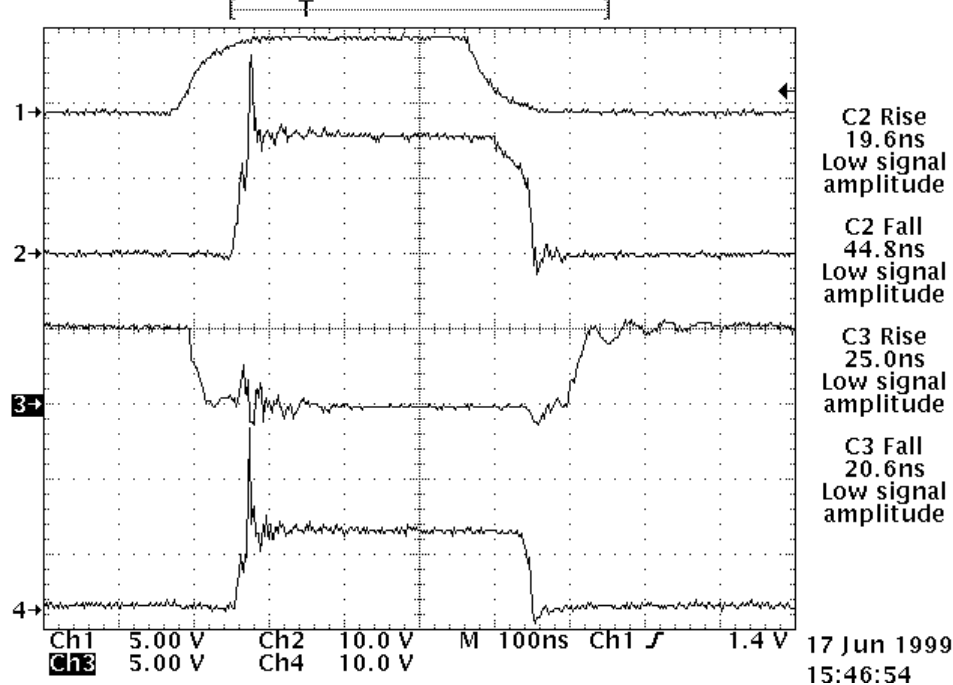

Figure 4-Timing diagram:

- Ch1:CO input
- Ch2:TG drive
- Ch3:BG non-overlap drive
- Ch4:phase node  
I<sub>out</sub>=20A (10A/phase)  
Refer to Eval. Schematic (fig.3)

Tek Run: 500MS/s ET Sample

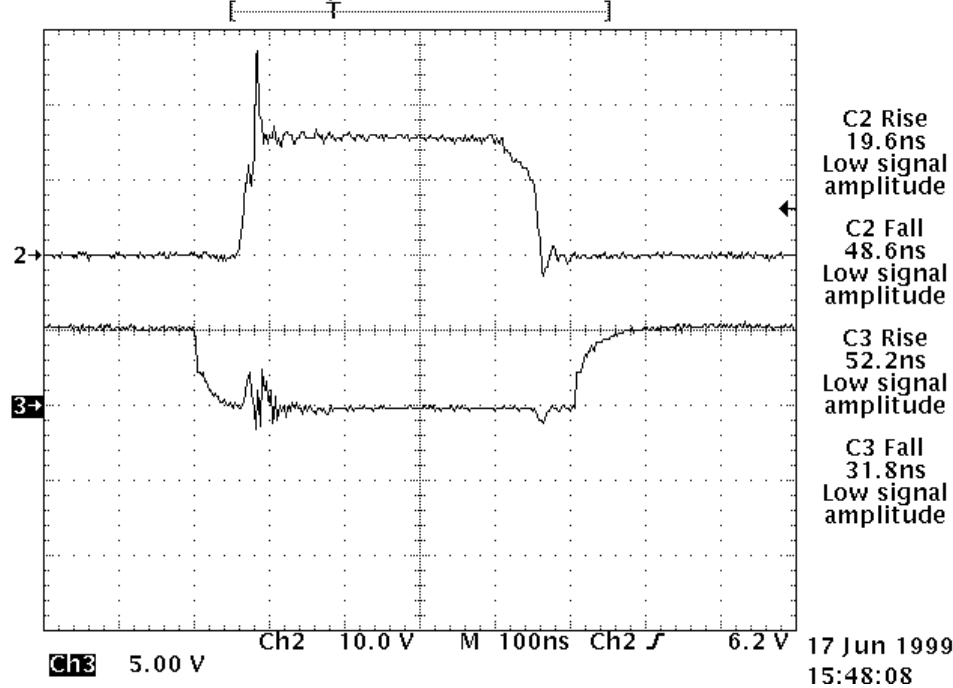
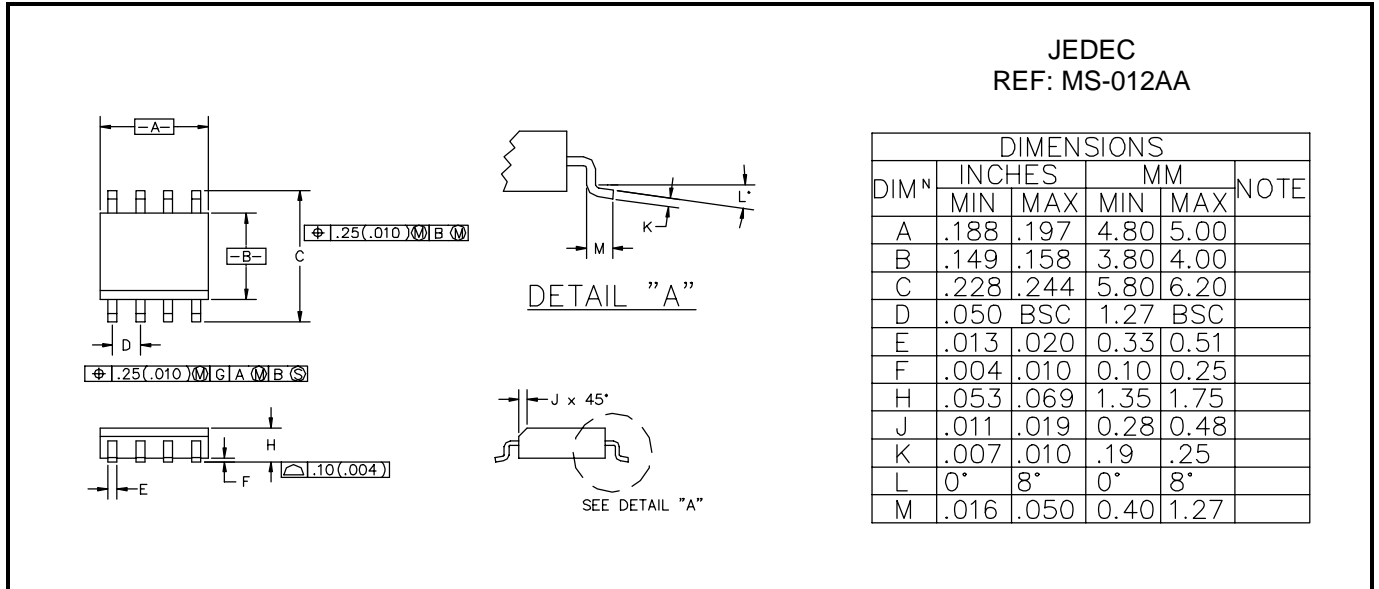
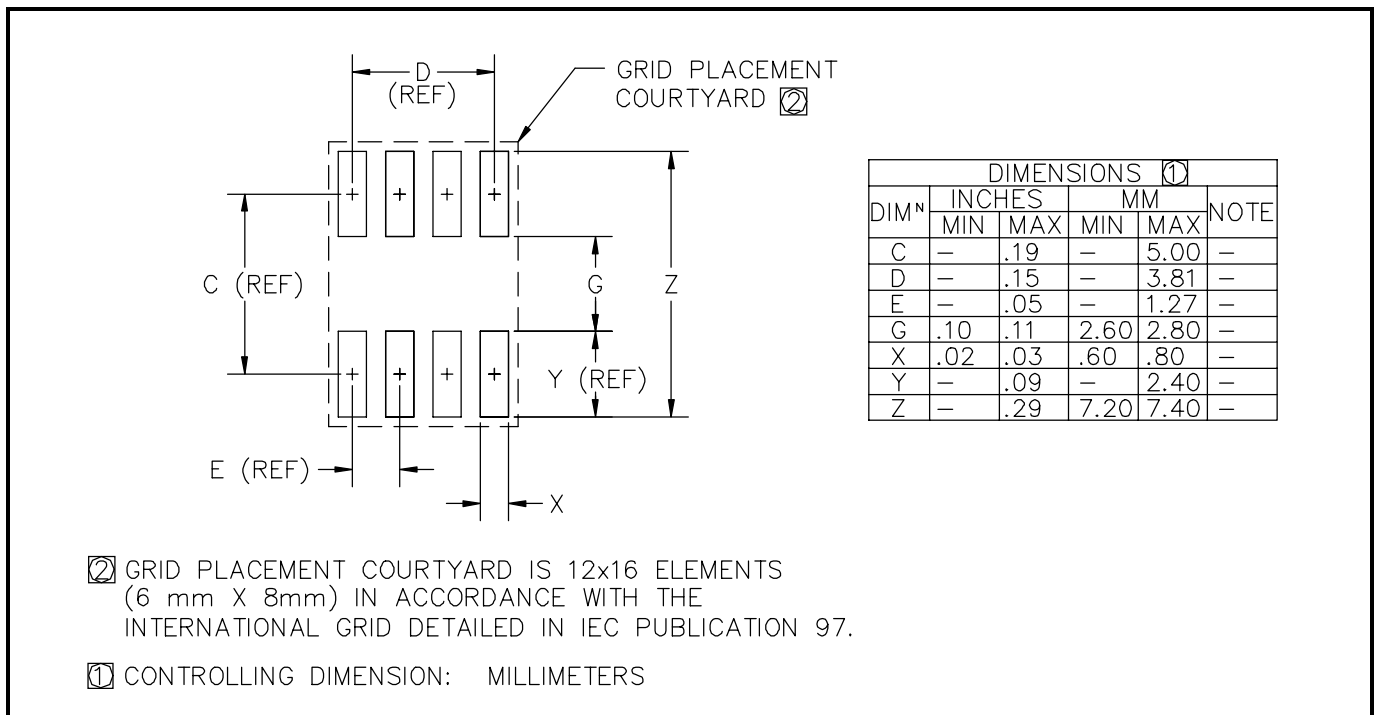

Figure 5-Timing diagram:  
Rise/Fall times

- Ch1:TG drive
- Ch2:BG drive
- Cursor:T<sub>pdh<sub>TG</sub></sub>
- I<sub>out</sub>=20A (10A/phase)  
Refer to Eval. Schematic (fig.3)

PRELIMINARY - December 7, 1999

**OUTLINE DRAWING - SO-8**

**LAND PATTERN - SO-8**

ECN99-742